

Cooling



Peugeot Citroen applications

COTB 0009

FWP 1937 & FWP 2125

Concerns

Concerns have been raised over the difficulties some customers have encountered when fitting the above pumps to the OE plastic back housings. This is in part due to the mounting holes of the pump having a diameter of 6.70mm and the use of M6 securing bolts which can allow misalignment.

It is important to note that there are two possible impellor sizes that can be fitted to the vehicle, 55mm and 61mm. Check the dimensions of the old pump before selecting its replacement.

When installing the new pump to the engine, ensure that there is no distortion evident in the original backhousing as this will compromise fitting of the replacement pump correctly.

Position the face of the pump against the engine block as illustrated and finally ensure that the impellor is free to turn without any fouling of the impellor and backplate.

If there is any evidence of impellor fouling then the complete pump with backhousing FWP 2206 should be fitted.

This pump replaces both FWP 1937 and FWP 2125 versions.

Cooling



Peugeot Citroen Applications

COTB 0009

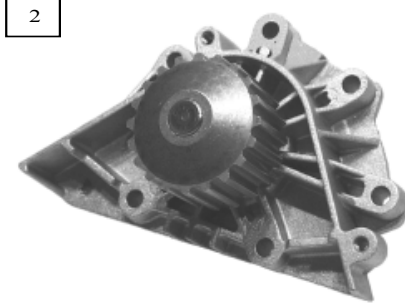
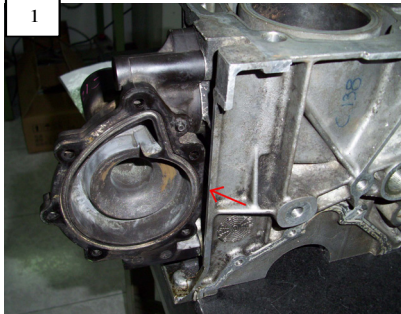

Ensure that the pump is located with the face against the cylinder block as illustrated in pic 3

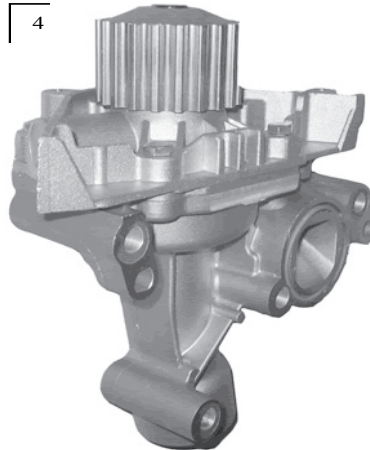
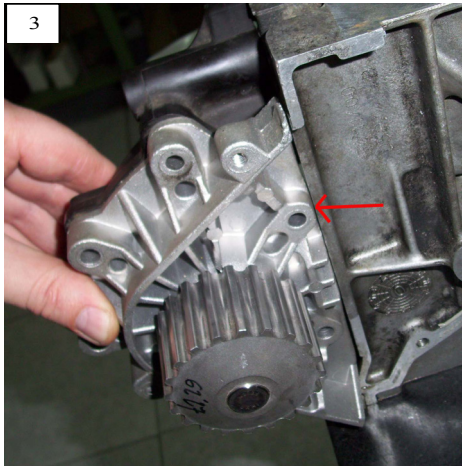

If satisfactory installation is not possible due to distortion of the backhousing replace complete pump (pic 4)

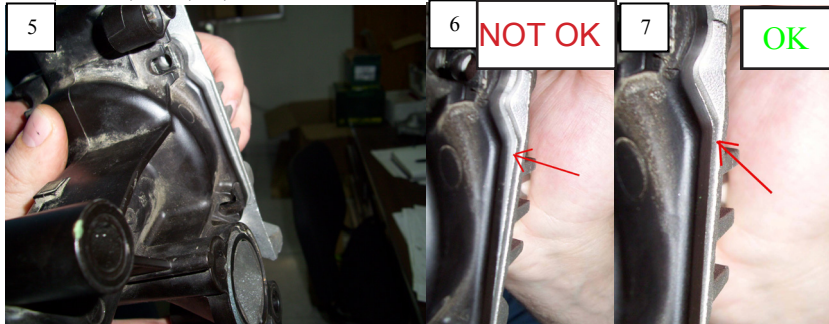

For correct assembly of the water pump it is recommended:

1. Fit the backhousing to the engine block (pic 1)
2. Assemble the water pump in the backhousing as is shown in picture 3 (the water pump touching against the engine in block)

Note: There are plastic and aluminium OE back housings even with different numbers of water pump assembly holes. An incorrect assembly of the water pump to the back housing can produce noise because the impeller blades touching the back housing.