

JURATEK

DAF1110

Splined Disc With Intermediate Elements

to fit:

DAF: XF95, 105 series, CF65, CF75, CF85 series,
FODEN: Alpha series

Alternative OE ref: Z0009911, K004322,
i139112F, i139541F, 1387349, 1640561

This new design reduces the fitting and removal times due to the simpler fitting elements and increases the strength of the fitting.

The original design has 20 intermediate spacers that can be difficult to install and even more difficult to remove.

Juratek have increased the size of the intermediate splines and replaced the 10 spring washers with an integrated fixing ring.

This new design also gives added strength to the intermediate splines. This increased strength comes from the intermediate splines being increased in width and the weight reduction space being filled. (see fig 1 & 2)

This can prevent the splines from separating from the disc when under stress.

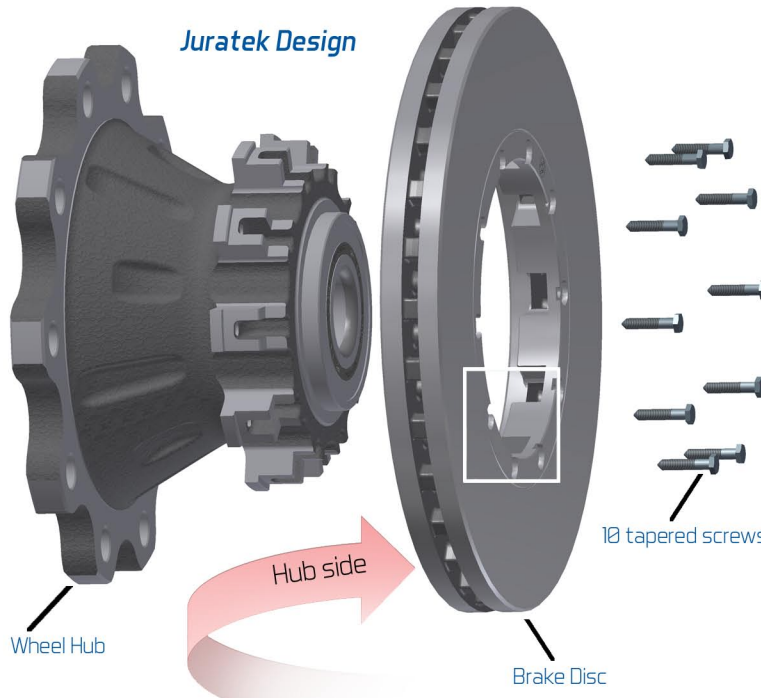
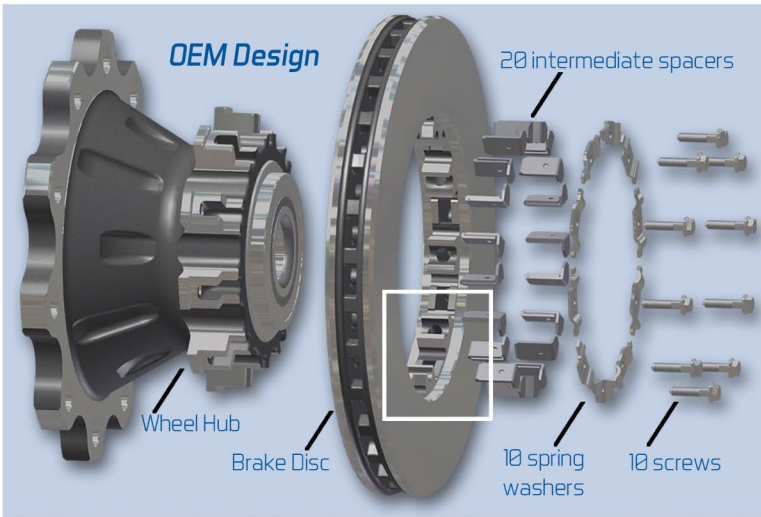

New Development 2016

A further development has been made to further simplify the fitting of the disc to the hub. Instead of a separate fitting ring (which allows for further wear to the hub), the fitting ring is now cast as part of the disc itself.

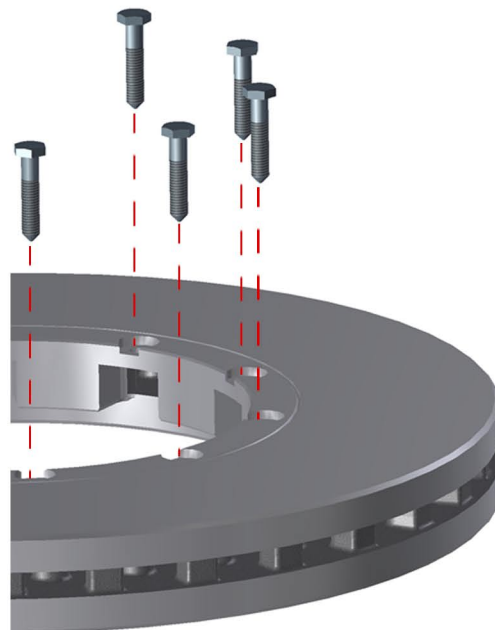

OEM Design

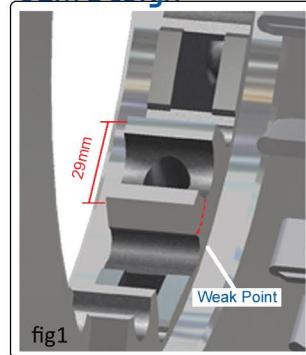

Juratek Design

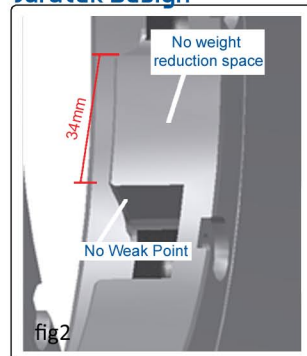

www.juratek.com



Distributed by:

your Logo and details here