



Connecting rod

fits VW Sharan (ref. no. 7M3 411 371C)
 Seat Alhambra (ref. no. 7M3 411 317C)
 Ford Galaxy (ref. no. 1 361 653)

>> PROBLEM:

The parts cause noise whilst driving.

>> CAUSE:

Due to its design and location (refer to picture 1) the connecting rod is subject to strong external forces. Both joints are completely exposed to water spraying up from wet roads. A damaged rubber boot (refer to picture 2 and 3), i.e. damaged by road debris, makes it easier for water and dirt to find its way into the joints. Consequently the protective grease will be washed out and the ball pin oxidises. As a result of this, the roughened ball surface increases wear to the plastic ball cup (refer to picture 4), which leads to the joint moving around and causing noise.

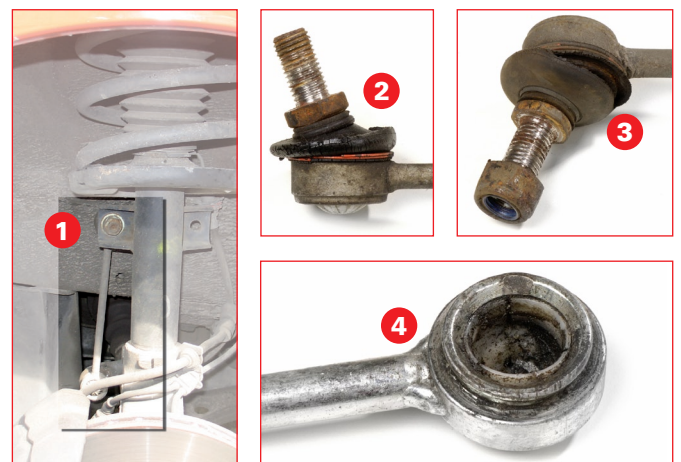

>> SOLUTION:

Rubber bellows (refer to picture 5):

- High performance rubber compound ensures the required flexibility
- Shaped to seal the joint system at each angle
- Proven grease resistance

Piston rings (refer to picture 6):

- The locking rings are specifically designed for this application, in order to support the sealing characteristics of the rubber boot

The grease:

- Use of high performance grease for the ideal lubrication of the ball cup (refer to picture 7) and the ball pin
- Corrosion protection for the whole system

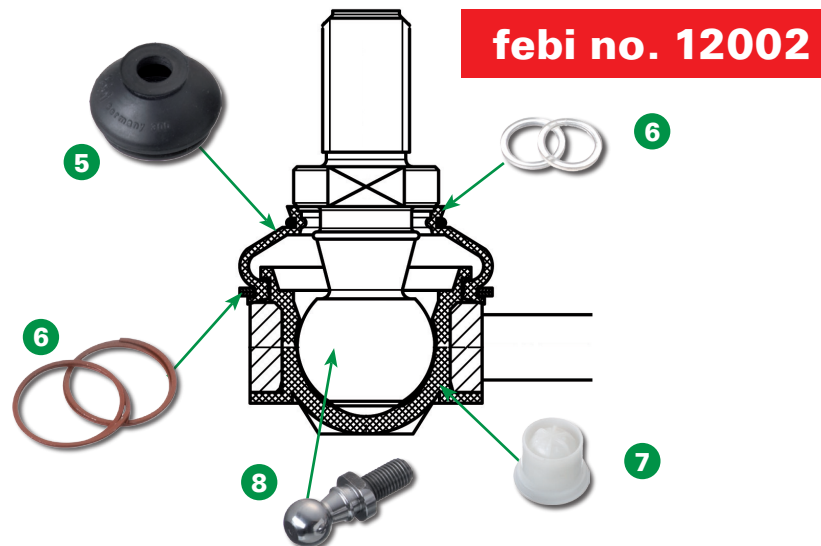

>> ATTENTION:

The use of unsuitable tools when fitting, the rubber bellows having contact with aggressive liquids (i.e. brake fluid) or contact with other parts caused by an accident or bumps can cause damage to the rubber bellows and lead to a premature failure of the connecting rod. While fitting, always follow the manufacturers' installation instructions.

Subject to technical alterations