

Noise Occurrence on GDB1363 and GDB1431

noise. The arrow indicates the disk forward rotation. If the Brake Pads are not fitted as shown above, noise will occur. To ensure the correct fitment in future TRW will print indicator arrows on the back plate.

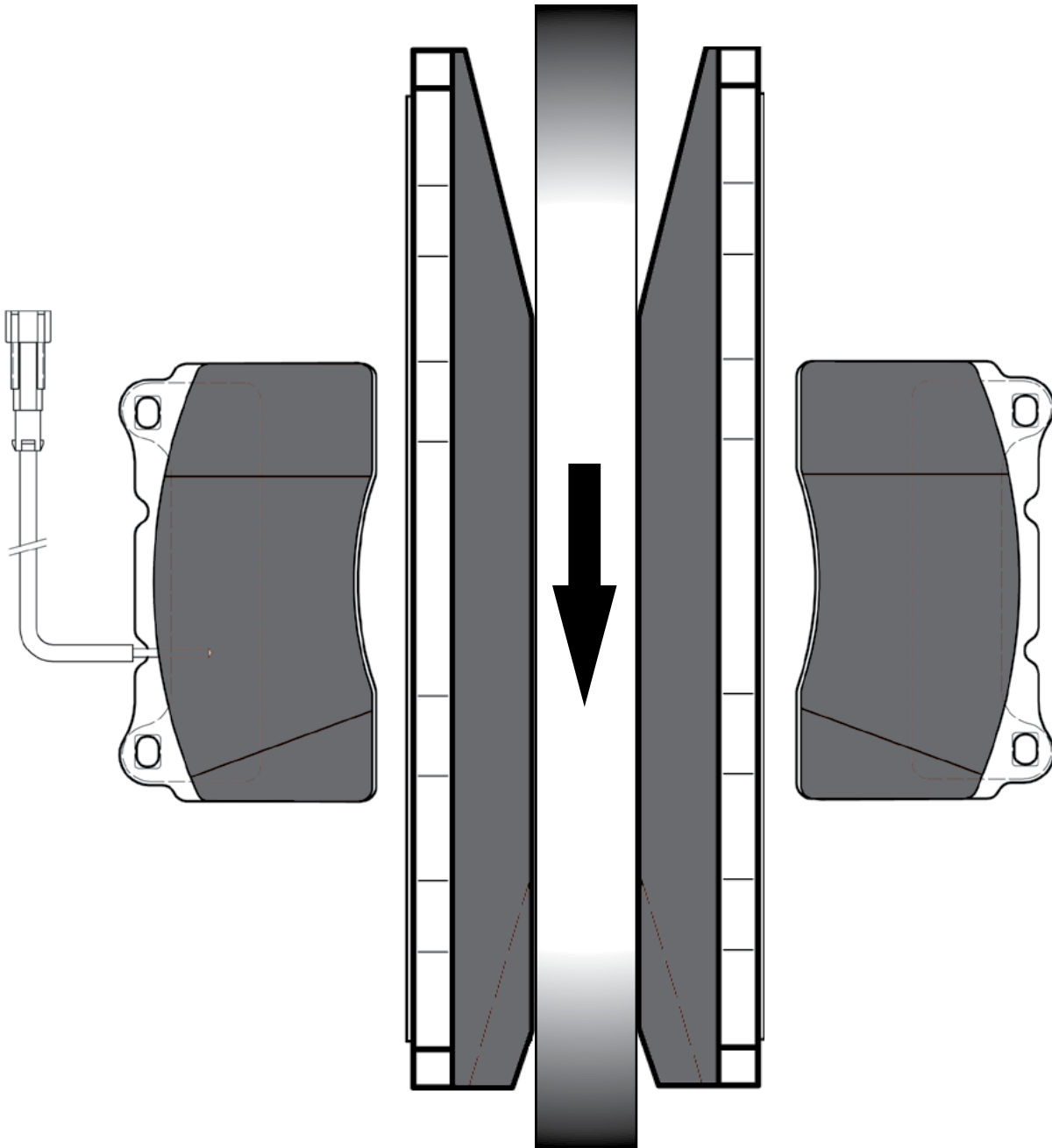