



FORD 1.8 D / Synchronous Drive / Installation Info.

GATES REFERENCE:
5541XS & related kits.
MAKE :
MODEL :
FORD / MAZDA.
 121, C-Max, Courier, Fiesta, Focus, Galaxy,
 Mondeo, S-Max, Tourneo, Transit.

MOTOR :
MOTOR CODE :

 1.8 TD, TDCI, TDDI (all 8 valves).
 Multiple.

Explanation:

Although this drive looks very simple and although it is equipped with an automatic tensioner, precise follow up of the complete installation procedure is needed in order to get the correct set-up/tension. Failure to follow these instructions will lead to engine damage.

Attention points:

- 1) The engine must be cold: the engine temperature significantly influences the installation parameters.
- 2) The engine must be at TDC. All engine specific setting & locking tools can be found in Gates tool kit GAT4830.
- 3) The crankshaft has to be locked (when equipped with air conditioning, the alternator shaft has to be removed, 6 bolts to loosen).
- 4) The camshaft has to be blocked (at the back of the engine).
- 5) The camshaft sprocket bolt has to be loosened. Make sure the sprocket is free to rotate on the taper, by using the sprocket remover in tool kit GAT4830 (if not done so, the belt will not be tensioned in the top span).
- 6) Turn the tensioner anticlockwise, until the indicator is in **the middle of the slot** (not lined up with the mark on the tensioner). (Fig. 1)

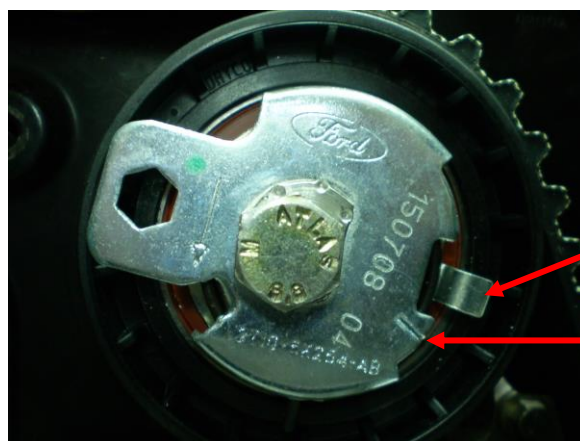
 Indicator in middle
 of the slot. ✓

Mark on the tensioner

Fig. 1a



(Fig. 1b +1c)

- 7) Torque the tensioner bolt (50 Nm) **while holding the tensioner in place.**
- 8) Torque the camshaft bolt (50 Nm) **while holding the sprocket in place.** Use Gates sprocket holding tool GAT4844.
- 9) Remove the camshaft and crankshaft locking tools.
- 10) Turn the engine nearly 6 revolutions by hand.
- 11) Re-insert the crankshaft pin; rotate the engine further till TDC.
- 12) Check the tensioner indicator position, if not in the middle of the slot, restart the tension setting procedure.
- 13) Insert the camshaft locking tool (at the back of the engine). If not possible, restart the tension setting procedure.

Failure to do all the above will lead to wrong tension, with possible tracking of the belt as a result. The belt will climb over the camshaft sprocket flange, running into the timing cover (Fig. 2 and Fig. 3).

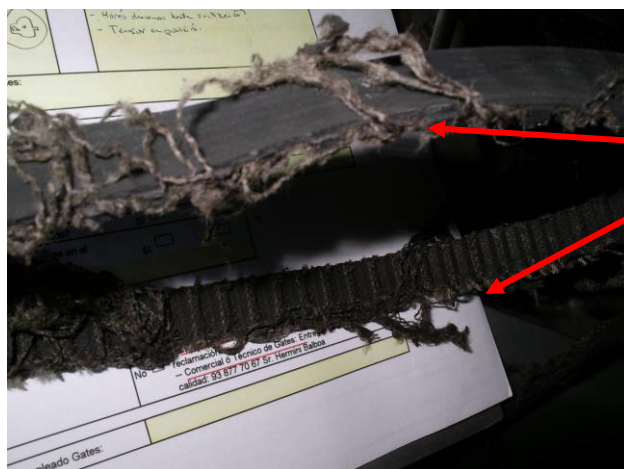

Typical wear pattern of the side of the belt

Fig. 2





Signs of serious wear on inside of the cover due to contact with the side of the belt

Fig. 3

Additional attention points:

1. Camshaft pulley



Extension AC

Fig. 4

Check if the part number of the camshaft pulley ends with **AC** (Fig. 4). In case the part number of the camshaft pulley ends with **AB**, fit a new sprocket with OE ref. XS4Q6A256**AC**.

2. Automatic tensioner

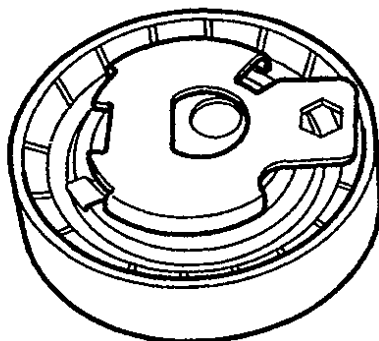

New automatic tensioner

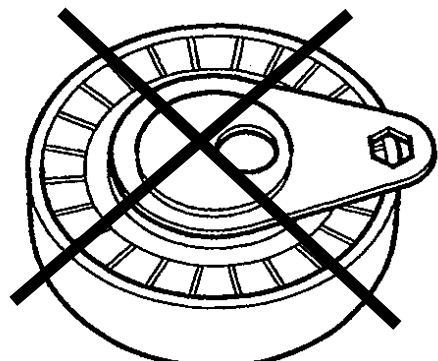

Old manual tensioner

Fig. 5

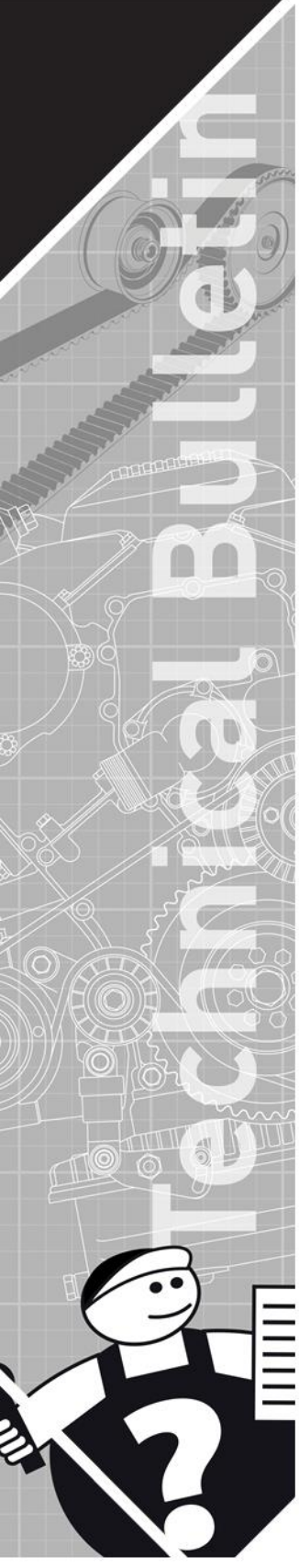



Fig. 5 shows the initial manual tensioner on the right side and the current automatic tensioner on the left.

3. Timing belt cover

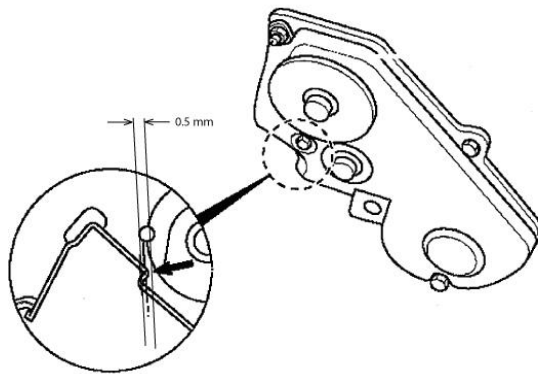

Fig. 6

When the manual tensioner is replaced by an automatic tensioner, the timing belt cover has to be slightly modified.

File off the inner corner (0.5 mm) as shown in Fig. 6.

Do not damage the timing belt cover by filing off too much of the corner!

Ignoring the above guidelines can seriously damage your engine!



visit our web catalogue: <http://www.gatesautocat.com>