

# Blue Print Top Tip

Land Rover Discovery 3, 4, Range Rover Sport / Jaguar S-Type, XF, XJ 350 - Oil Filter Replacement

Applicable References: ADJ132102

Applications: 2.7 V6 Diesel 2004>2012

Date Issued: 06/2014

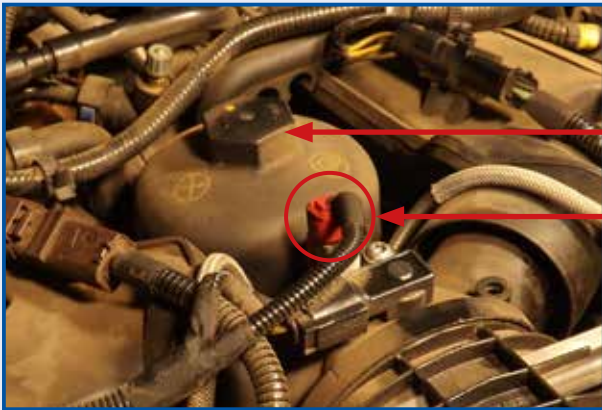

On removal of the engine cover, you will find the oil filter element housing in the centre of the engine at the top.

The element housing requires a 32mm socket to undo the housing.

When undoing the housing, care must be taken not to damage the fuel temperature sensor located in front of the housing.

On removal of the filter housing the old element needs to be removed using an oil filter element removal tool. **(BP Part No. ADJ135502).**

This is due to the tight interference fit of the element in the housing cap.

## Oil filter element spigot recess.

Clean the housing and replace the 'O' Ring seal, then fit the new oil filter element.

The oil filter element can be fitted two ways, either directly into the oil filter housing or fitted direct into the oil filter housing cap.

On replacement, make sure the oil filter element spigot aligns with the hole in the filter housing on the engine.

Incorrect alignment will be noticed by resistance when fitting the plastic housing cap on the engine. There is a risk of damage to the filter housing, oil leaking and the oil pressure not being reached after engine start up, if the spigot is not aligned.

Tighten element housing to 25Nm (18 lb ft).



ADJ135502

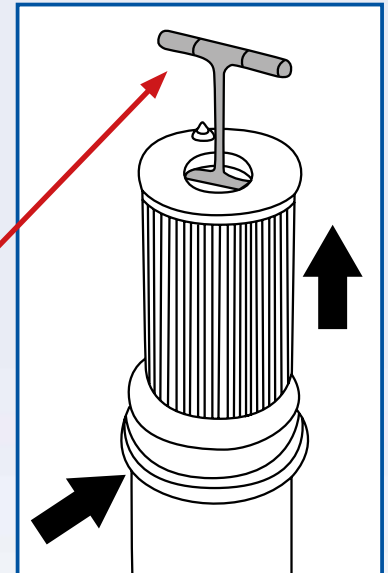

[www.blue-print.com](http://www.blue-print.com)

Blue Print is a bilstein group brand

**Disclaimer:** Any technical tips are produced in good faith. Ferdinand Bilstein UK Ltd. always recommend that vehicle maintenance and diagnostics are only carried out by suitably experienced people using appropriate tools in a safe manner within a workshop environment. Ferdinand Bilstein UK Ltd. and their customers cannot be held responsible for the correctness of, or misinterpretation of the above technical tips. Images shown are for illustrative purposes only and may not be representative of the products or vehicles described.