

Technical Bulletin

Chevrolet / Citroen / Fiat / Peugeot / Saab / Suzuki / Vauxhall/Opel - Fuel Filter Removal Tool Instructions

Applicable References: ADK85502, ADK82327

Applications: Various JTD Diesel

Date Issued: 05/2011

Blue Print's Fuel Filter Removal Tool, ADK85502, is an OE developed tool that makes replacement of the fuel filter element on vehicles fitted with the JTD type engine a much quicker and easier job and, most importantly, greatly reduces the risk of damage to the intricate and expensive plastic filter housing or fastening ring.

ADK85502

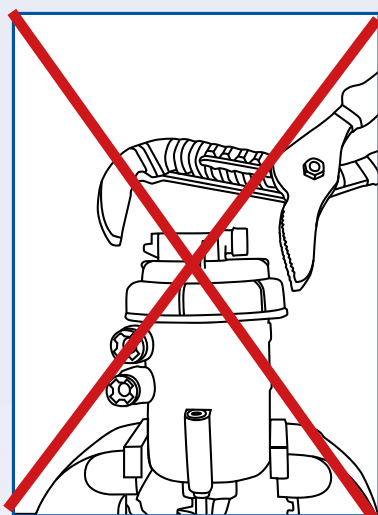
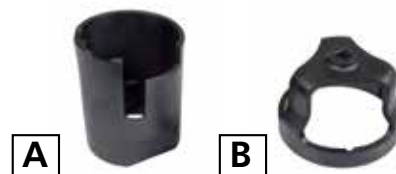

Clamping the plastic housing in a vice and attempting to loosen the filter fastening ring with a large pair of metal-jawed grips is highly likely to result in damage.

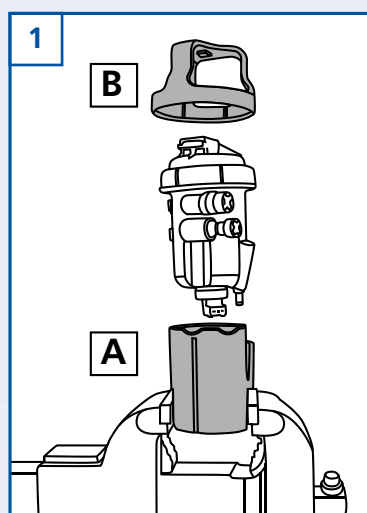

Clamp part 'A' into a vice. Remove fuel filter housing from vehicle, taking care to remove all pipes and all electrical connectors. Place the filter housing into part 'A' and locate part 'B' onto the top of the housing, aligning the six slots of the tool with the filter housing fastening ring.

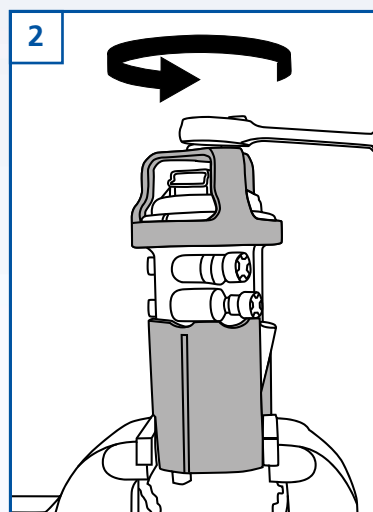

Using a 1/2" drive ratchet simply undo the fastening ring by turning part 'B' anti-clockwise.

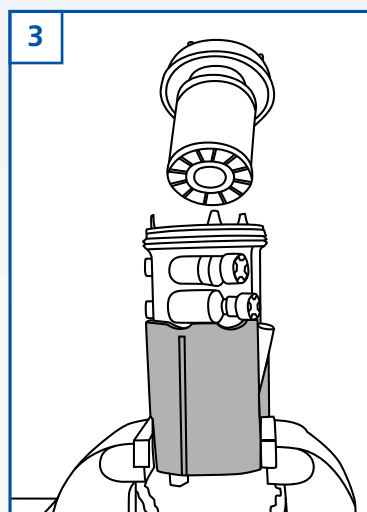

Extract the upper section of the filter housing and replace the fuel filter element (**ADK82327**) taking care not to touch the filter paper on the new element.

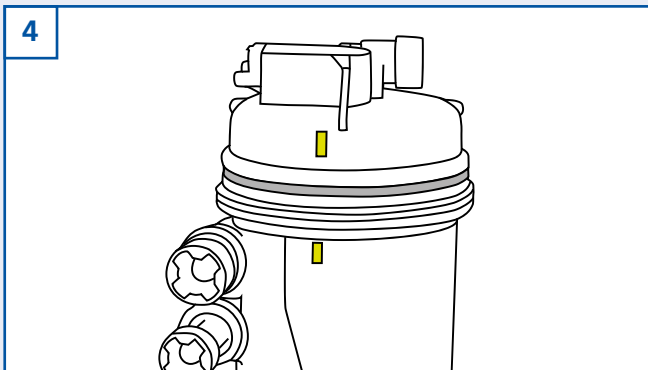

Replace the rubber seal between the two sections of the housing with the one supplied with the new filter. Refit the upper section to the housing by aligning the yellow/green markers.

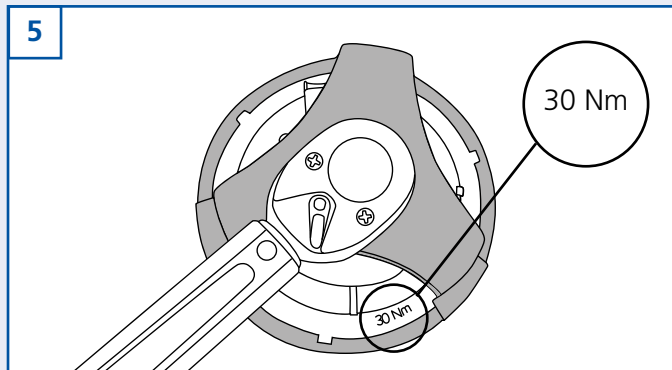

Tighten the fastening ring to 30Nm, then refit the housing to the vehicle and reconnect all fuel pipes and electrical connectors. Start the engine and check for leaks.

Note: The fuel filter is 'self bleeding'.

Blue Print's Fuel Filter Removal Tool is suitable for use on vehicles that are fitted with a diesel fuel filter element equivalent to Blue Print part number **ADK82327**.

Applications include:

Chevrolet Captiva 2.0 VCDi	2007>
Chevrolet Epica 2.0 VCDi	2008>
Chevrolet Lacetti 2.0 VCDi	2007>
Chevrolet Nubira 2.0 VCDi	2007>
Citroen Relay, Jumper 2.0, 2.2, 2.8, 3.0 HDi	2002>
Fiat 500 1.3 JTD	2007>
Fiat Doblo 1.3 JTD	2000>2010
Fiat Ducato 2.0, 2.2, 2.3, 2.8, 3.0 JTD	2002>
Fiat Idea 1.3, 1.9 JTD	2004>
Fiat Multipla 1.9 JTD	2002>2010
Fiat Panda 1.3 JTD	2004>
Fiat Punto 1.3, 1.9 JTD	2001>2010
Fiat Sedici 1.9, 2.0 JTD	2006>
Fiat Croma 1.9 JTD	2005>2007
Fiat Strada 1.3 JTD	2005>2011
Lancia Musa 1.3, 1.9 JTD	2004>2012
Lancia Ypsilon 1.3 JTD	2003>2011
Peugeot Boxer 2.0, 2.2, 2.8, 3.0 HDi	2002>
Saab 9-3 1.9 TiD	2004>2006
Saab 9-3, 9-3X	2002>
Subaru Justy G3X 1.3 DDiS	2003>
Suzuki Splash 1.3 DDiS	2008>
Suzuki Ignis 1.3 DDiS	2003>2008
Suzuki Wagon R 1.3 DDiS	2004>2007

ADK82327



Suzuki Swift 1.3 DDiS	2005>
Suzuki SX4, SX4 S-Cross 1.6, 1.9, 2.0 DDiS	2006>
Suzuki Vitara 1.6 DT	2015>
Vauxhall/Opel Agila 1.3 CDTi	2008>
Vauxhall/Opel Antara 2.0 CDTi	2006>2011
Vauxhall/Opel Astra 1.3, 1.9 CDTi	2004>2010
Vauxhall/Opel Corsa 1.3 CDTi	2003>2006
Vauxhall/Opel Combo 1.3 CDTi	2004>
Vauxhall/Opel Meriva 1.3 CDTi	2005>2010
Vauxhall/Opel Signum 1.9 CDTi	2004>2008
Vauxhall/Opel Tigra 1.3 CDTi	2004>2009
Vauxhall/Opel Vectra 1.9 CDTi	2004>2008
Vauxhall/Opel Zafira 1.9 CDTi	2005>

The Blue Print Warranty will apply to the application of **ADK82327** to vehicles not in our catalogue, as per our Warranty Statement (see website for details).

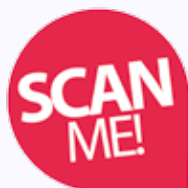

To See the video:

Disclaimer : Any technical tips are produced in good faith. Ferdinand Bilstein UK Ltd. always recommend that vehicle maintenance and diagnostics are only carried out by suitably experienced people using appropriate tools in a safe manner within a workshop environment. Ferdinand Bilstein UK Ltd. and their customers cannot be held responsible for the correctness of, or misinterpretation of the above technical tips. Images shown are for illustrative purposes only and may not be representative of the products or vehicles described.

www.blue-print.com
Blue Print is a bilstein group brand