

## Flame start

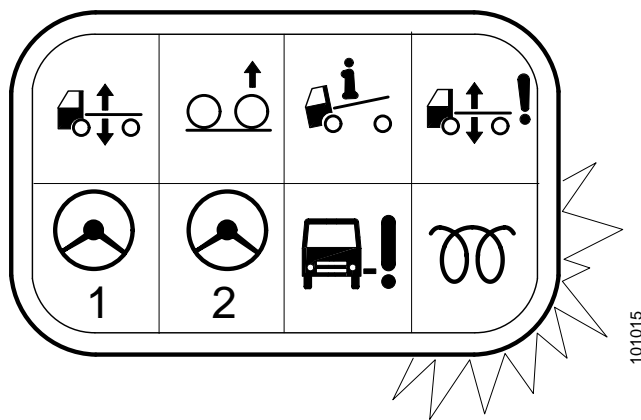

### Contents

General .....	2
Components .....	4
Fault diagnosis .....	6
Wiring diagram .....	7
Testing .....	8
Specifications .....	8

## General

The flame start is used to limit the emission of white smoke. It also makes starting easier in extremely cold weather.

### Starting the engine

If the temperature of the coolant is below +10 °C when the starter key is turned to the drive position (position 15), the heater plug will be automatically activated.

At the same time, the indicator lamp will give off a **steady light**. After about 20 seconds (at a battery voltage of 24 V), the lamp will **start to flash**.

If the temperature of the coolant is above +10 °C, the indicator lamp will start to **flash immediately**.

The engine can then be started.

If the temperature of the coolant is below +10 °C when the starter key is turned to the start position (position 50), the solenoid valve will be activated, fuel will be injected into the system and ignited by the heater plug.

When the starter key is returned to the drive position, the indicator lamp lights up with a **steady light** and the after-heating phase begins.

The heater plug and solenoid valve receive voltage for up to three minutes or until the temperature of the engine reaches 60 °C, during which time the indicator lamp continues to give off a **steady light**. After-heating raises the temperature of air inducted into the system and limits the amount of white smoke emitted.

During this period, the engine speed should not exceed 1000 rpm.

If the engine fails to start within about 30 seconds (and the indicator lamp goes out), the starter key must be returned to the stop position (position B). Wait 20 seconds before making a new attempt to start the engine, then turn the key to the drive position to activate the flame start afresh.

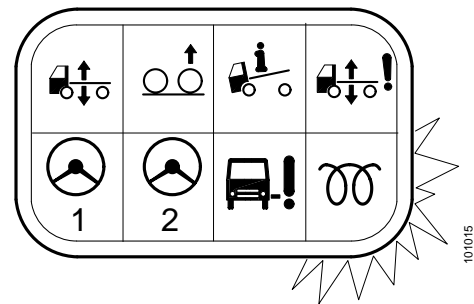

## Switching off the engine

In the following situations, the flame start switches off automatically and the indicator lamp goes out:

- if an attempt is made to start the engine when the indicator lamp is giving off a steady light;
- if the engine has been switched off.

## Components

### Control unit

The control unit (E26) collects information which it then uses to open or close the solenoid valve and to control the heater plug relay and the indicator lamp.

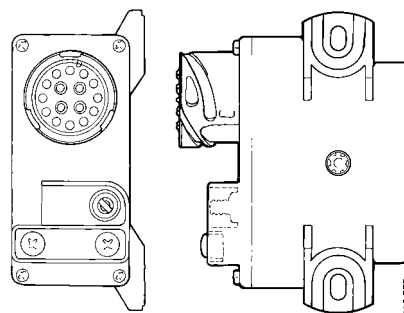

Location of the components in the engine.

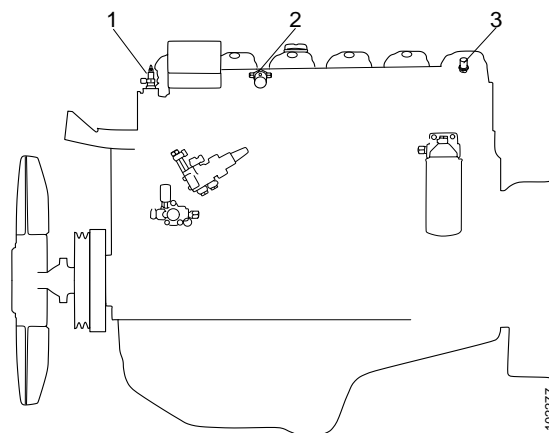

- 1 Heater plug
- 2 Solenoid valve
- 3 Temperature sensor

### Solenoid valve

The solenoid valve (V58) is controlled by the control unit. It opens and closes the supply of fuel.

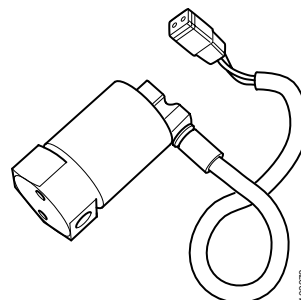

## Heater plug

The heater plug (H10) is located on the induction pipe. Its purpose is to inject and ignite fuel. Ignition occurs when the fuel passes the heater plug spiral. The spiral must first be heated up for about 20 seconds to attain the necessary temperature.

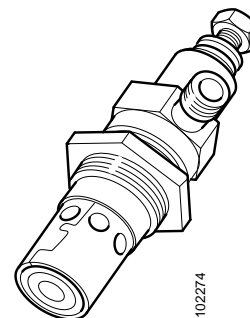

## Temperature sensor

The temperature sensor (T77) measures the temperature of the coolant.

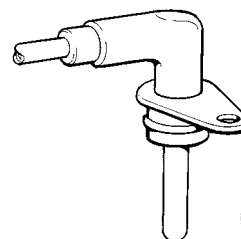

## Fault diagnosis

When the starter key is turned to the drive position (position 15), any fault codes that have been registered (see the table) will be immediately presented on the display. The code '2-2...' signifies two rapid flashes followed by a pause, followed by two rapid flashes, and so on.

If several fault codes are active at the same time, only the fault code with the highest priority will be shown. The order of priority is given below in the table.

In all three cases, both the heater plug and the solenoid valve will be deactivated.

The fault-code lamp flashes for about 60 seconds.

When a fault has been rectified, the key must be turned to the locking position (position 0) in order to clear the fault codes.

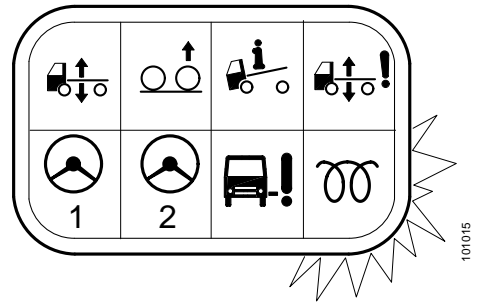

Fault code	Cause	Priority
2-2-2-2-...	A break in the heater plug, or a break between the heater plug and the control unit of the flame start.	1
3-3-3-3-...	The fuse in the control unit of the flame start has blown or there are difficulties in supplying the control unit with power.	3
4-4-4-4-...	A break between the control unit of the flame start and the solenoid valve, or a break in the solenoid valve coil.	2

# Wiring diagram

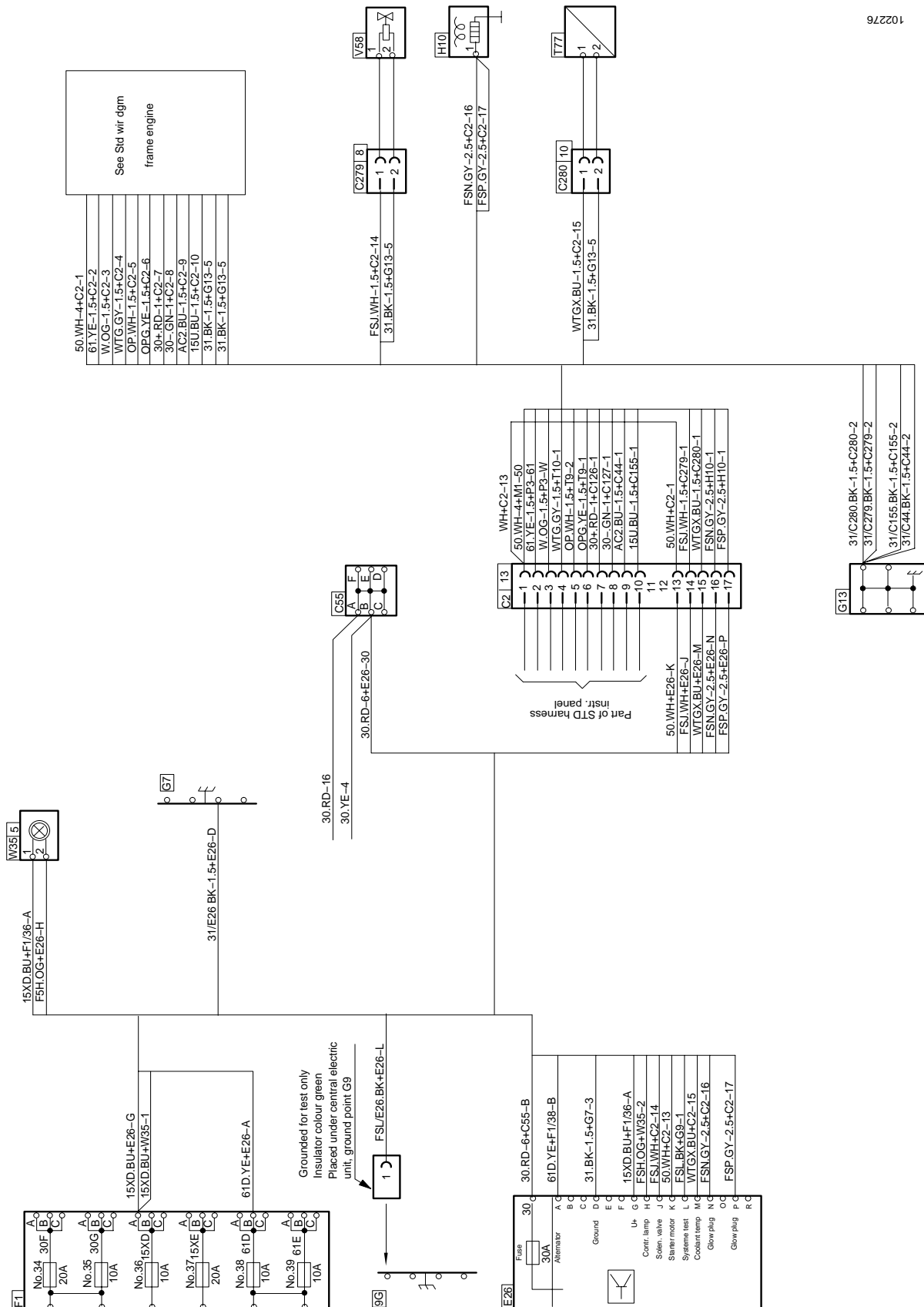

## Testing

A special test cable is available for testing the system. It is black, marked FSL/E26 with a green insulator marked G9. The cable is strapped to the cable cluster that leads behind earth G9, to the left beneath the central electric unit.

- |   |   |  |
|---|---|--|
| 1 | Earth the test cable to G9.                               | The cable is black with a green insulator.   |
| 2 | Turn the starter key to the drive position (position 15). | The indicator lamp gives off a steady light for about 20 seconds while the heater plug is being heated up, after which it then begins to flash.                                  |
| 3 | Turn the starter key to the start position (position 50). | When the engine has started, the indicator lamp will give off a steady light. The solenoid valve (for the fuel) and the heater plug will both be active for about three minutes. |

**Important!** The test cable should be disconnected from G9 after testing. It **should not** be earthed during normal operating conditions.

## Specifications

### Heater plug

Voltage.....	24 V
Current .....	13 +/- 1 A for 20 secs.
Tightening torque:	
Heater plug nut (M20) .....	max. 25 Nm
Cable terminal connection (M5).....	max. 4 Nm
Fuel pipe connection (M10) .....	max. 10 Nm