

SCANIA

03:02-05

Issue 1 en

Special functions

Using the power take-off

Function and Work Description

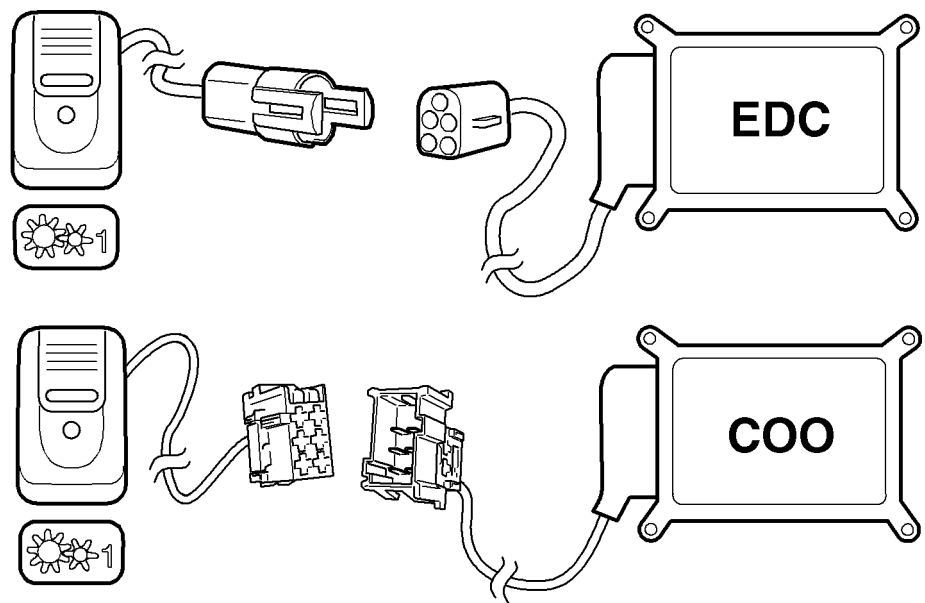

126 478

cardiagn.com

Contents

| | | |
|----------------------|--|----|
| Function description | General | 3 |
| | Connecting the special functions..... | 4 |
| | Activating the special functions | 5 |
| | Emergency stop | 5 |
| | Engine speed control | 6 |
| | Torque limitation | 15 |
| Speed limit..... | 18 | |
| Work description | Connecting the special functions..... | 19 |
| | External engine control..... | 24 |

Function description

General

The special functions which can be engaged and activated on the vehicle are described here. The special functions which are available are as follows:

- Emergency stop
- Limited hand throttle (engine speed control mode 1)
- Raised idling speed (engine speed control mode 2)
- Fixed engine speed (engine speed control mode 3)
- Torque limiter 1 (provides a traditionally peaked torque curve)
- Torque limiter 2 (gearbox with torque converter)
- Torque limiter 3 (early breakaway)
- Speed limit 2

The following limitations can be set - using Scania Programmer - for the special functions **Limited hand throttle** and **Fixed engine speed**.

Limited hand throttle

- Maximum torque
- Maximum engine speed
- Accelerator pedal (disconnected or otherwise)

Fixed engine speed

- Maximum torque (not for all MS5, introduced from 02.98)
- Engine speed (constant)

Connecting the special functions

Vehicle without coordinator

In vehicles without coordinator, the special functions are connected by earthing some of the EDC control unit pins via connector C107.

The Speed limit 2 function can be connected by energising one of the EDC control unit pins with +24 V.

How the different functions are connected is described in the section Work description.

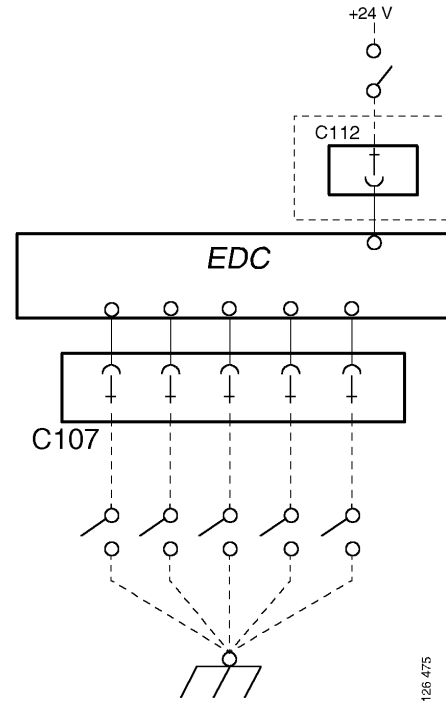

Vehicle with coordinator

In vehicles with coordinator, the special functions are connected by earthing some of the coordinator pins via connector C271.

The EDC control unit will then receive a CAN message from the coordinator about which function is requested.

How the different functions are connected is described in the section Work description.

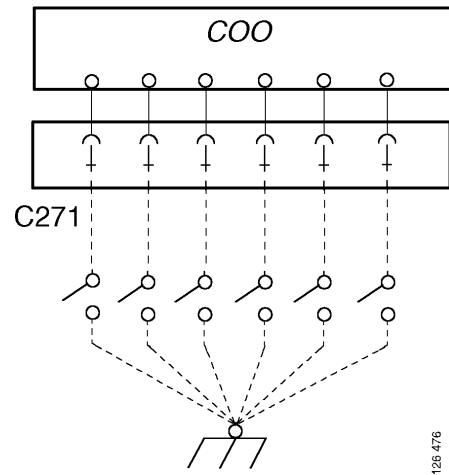

cardiagn.com

Activating the special functions

The special functions can be activated in different ways depending on the application. It can be either manually by the driver using a switch or automatically by a specific device being actuated.

Emergency stop

The emergency stop function makes it possible to stop the engine quickly in emergencies such as an accident when operating a crane.

When the function Emergency stop is activated, the engine is immediately switched off if the vehicle is standing still. When driving, the throttle actuation is reduced to idling speed but the engine is not switched off. This allows the continued use of power steering for example.

The function is activated by earthing a pin on connector C107 or C271.

There is a stop button in the engine compartment in buses.

Engine speed control

Engine speed control is a name common to four different functions which are used to control engine speed. The functions are named as follows:

Normal hand throttle, mode 0

Limited hand throttle, mode 1

Raised idling speed, mode 2

Fixed engine speed, mode 3

In normal cases, Normal hand throttle will be used. This means that the engine does not have any special engine speed restrictions.

It is possible to connect an extra electrical system, so that the correct function is automatically activated when the unit for the extra system is used.

If several of the functions need to be used, the pins can be earthed on the EDC control unit or coordinator in different combinations via a switch. More information about this can be found in the work description.

For a description of how the engine reacts when each function is activated, see next page.

Normal hand throttle (mode 0)

The Normal hand throttle function operates so that the engine maintains the engine speed that is selected with the control for the cruise control. The function operates in a similar way to the cruise control - the difference being that Normal hand throttle regulates the engine speed rather than the vehicle speed.

The engine speed can be regulated between 500 and 2000 rpm.

To enable the engine to maintain the selected engine speed, the EDC control unit controls the fuel injection after first having processed signals from the engine speed sensors.

In the Normal hand throttle function, the characteristics of the engine differ slightly between different engine types. Refer to Overview of engine characteristics.

This is how the normal hand throttle function is used

The function is activated manually by the driver using the control for the cruise control.

Preconditions

- The control for the cruise control should be in the ON position.
- The vehicle may not be driven at a speed greater than 10 km/h.

How to set the engine speed using the control for the cruise control

- Press RES, the engine will maintain the previously selected engine speed.
- Press ACC or RET to select a new engine speed.

Then press RES for at least 3 seconds to store the engine speed.

How to change to idling speed

- Press OFF
- or
- depress the brake or clutch pedal
- or
- activate the exhaust brake or the retarder.

Limited hand throttle (mode 1)

Using the Limited hand throttle function, it is possible to select an engine speed and an engine torque that the engine cannot exceed. The upper limits can be selected within the following ranges:

- 700 - 2000 rpm
- minimum. 200 Nm, maximum. the maximum engine torque available

In this way, a unit attached to the power take off can be protected from overloading for example.

The function is activated by earthing a pin on connector C107 or C271.

The characteristics above are set using Scania Programmer. Different engine speeds, which are below those set in Scania Programmer, can be set using the control for the cruise control.

Using Scania Programmer, it is also possible to select whether or not the accelerator pedal can affect the vehicle when the Limited hand throttle is activated.

In the Limited hand throttle function, the characteristics of the engine differ slightly between different engine types. Refer to Overview of engine characteristics during engine speed control.

This is how the limited hand throttle function is used (mode 1)

The function can be activated either manually by the driver using a switch or automatically by a specific device being actuated.

Preconditions

- The control for the cruise control should be in the ON position.
- The vehicle may not be driven at a speed greater than 10 km/h.

How to set the upper limits for engine speed and engine torque

- Set the upper limits for engine speed and engine torque in Scania Programmer.

How to set a new engine speed using the control for the cruise control

Only engine speeds which are below the limit set using Scania Programmer, can be set.

- Press RES, the engine will maintain the previously selected engine speed.
- First press ACC or RET to select a new engine speed.

Then press RES for at least 3 seconds to store the engine speed.

IMPORTANT! By reducing the engine speed limit using the Scania Programmer and earthing the pin, the engine speed will still increase to the speed that was set previously.

Therefore, before using the function, the function engagement should always be tested. Activate the function. Press ACC and then RES for three seconds to set the upper limit according to the Scania Programmer.

How to change to idling speed

- Press OFF
- or
- depress the brake or clutch pedal

or

- activate the exhaust brake or the retarder.

Raised idling speed (mode 2)

Using the Raised idling speed function, it is possible to select an engine speed that the engine must never be below. In this way, it is possible, for example, to fill the compressed air system or run the engine until warm. The function can also be used in vehicles equipped with a cement mixer.

The function is activated by earthing a pin on connector C107 or C271.

The lower engine speed limit is set with the control for the cruise control - between 500 and 800 rpm.

In the Raised idling speed function, the characteristics of the engine differ slightly between different engine types. Refer to Overview of engine characteristics.

This is how the Raised idling speed function is used (mode 2)

The function can be activated either manually by the driver using a switch or automatically by a specific device being actuated.

How to set the desired increased idling speed using cruise control

- Activate the function.
- The control for the cruise control must be in the ON position.
- Allow the vehicle to run at idling speed and set a new limit by pressing ACC or RET.

Then press RES for at least 3 seconds to store the engine speed.

How to change to normal idling speed

- Deactivate the function.

Fixed engine speed (mode 3)

The Fixed engine speed function can, using the Scania Programmer, be set with the following two limits for the engine.

- An engine torque that the engine may not exceed. The engine torque can be regulated between 200 and the maximum engine torque.
- An engine speed that the engine must maintain. The engine speed can be regulated between 600 and 2000 rpm.

The function is activated by earthing a pin on connector C107 or C271.

When these functions are active, the vehicle cannot be affected by using the accelerator or the control for the cruise control. The function can be used when work requiring high precision is required. i.e. when a crane with a long reach is to be used.

In the Fixed engine speed function, the characteristics of the engine differ slightly between different engine types. Refer to Overview of engine characteristics.

This is how the Fixed engine speed function is used (mode 3)

The function can be activated either manually by the driver using a switch or automatically by a specific device being actuated.

Preconditions

- The vehicle may not be driven at a speed greater than 10 km/h.

How to set the engine speed and the upper limit for engine torque

- Set the engine speed and the upper limit for engine torque in Scania Programmer.

How to change to idling speed

- Depress the brake or clutch pedal
or
- activate the exhaust brake or the retarder.

Overview of engine characteristics during engine speed control

| | EDC MS5 | EDC MS6 (EU2 ¹) | EDC MS6 (EU3 ²) and EDC S6 |
|-----------------------------------|---------|-----------------------------|---|
| Normal hand throttle (Mode 0) | A | A | B |
| Limited hand throttle (Mode 1) | A | A | A |
| Raised idling speed (Mode 2) | B | B | B |
| Fixed engine speed (Mode 3) | B | B | A |

1 = Engine types DC 1101, DC 1102, DC 1107, DSC 1203 and DSC 1205.

2 = Other engine types.

A = Rapid and more precise regulation of the engine speed. Irrespective of changes in the engine load, the engine speed will remain constant.

B = Slower regulation of the engine speed. This means that changes in the engine load can lead to temporary variations in the engine speed.

Overview of engine speed control

Shut off criteria

| | Mode 0 | Mode 1 | Mode 2 | Mode 3 |
|-------------------------|---------------|---------------|---------------|---------------|
| OFF | Yes | Yes | No | No |
| >10 km/h | Yes | Yes | No | Yes |
| Brake pedal | Yes | Yes | No | Yes |
| Exhaust brake | Yes | Yes | No | Yes |
| Retarder | Yes | Yes | No | Yes |
| Clutch pedal | Yes | Yes | No | Yes |
| Emergency stop function | Yes | Yes | Yes | Yes |

Activation of engine speed control

| | Mode 0 | Mode 1 | Mode 2 | Mode 3 |
|-----------------|---------------|---------------|---------------|---------------|
| ACC, RET or RES | Yes | Yes | No | No |

How to store an engine speed

| | Mode 0 | Mode 1 | Mode 2 | Mode 3 |
|--------------------------|---------------|---------------|---------------|---------------|
| RES for 3 seconds | Yes | Yes | Yes | No |
| Scania Programmer | No | No | No | Yes |
| Engine speed range (rpm) | 500 - 2000 | 500 - 2000 | 500 - 800 | 600 - 2000 |

What can be set using the Scania Programmer

| | Mode 0 | Mode 1 | Mode 2 | Mode 3 |
|--|---------------|---------------|---------------|---------------|
| Maximum engine speed | No | Yes | No | Yes |
| Maximum torque | No | Yes | No | Yes |
| Can the accelerator pedal be used when engine speed control is active | No | Yes | No | No |
| Can the engine speed control be used when a gear is engaged (only MS5 and MS6) | Yes | Yes | Yes | Yes |

Examples of how to set three fixed engine speeds

Certain types of bodywork may require one or more pre-set fixed engine speeds.

An example of how to pre-set three fixed engine speeds is shown here. Switching between them can be achieved using a switch that earths the pins.

The control for cruise control must be ON before the settings can be made.

Engine speed 1

Set engine speed 1 with the Raised idling speed function using the control for cruise control.

Engine speed range 500 - 800 rpm

Pin 5 on C107 or C271 is earthed.

Engine speed 2

Set engine speed 2 with the Limited hand throttle function using the control for cruise control.

Engine speed range 500 - 2000 rpm

Pin 1 on C107 or C271 is earthed.

Engine speed 3

Set engine speed 3 with the Fixed engine speed function. This function is programmed into the control unit using Scania Programmer.

Engine speed range 600 - 2000 rpm

Pins 1 and 5 on C107 or C271 are earthed.

Torque limitation

Torque limitation is a common term for four different functions that limit engine torque. The functions are named as follows:

No torque limitation, mode 0

Torque limiter 1, mode 1

Torque limiter 2, mode 2

Torque limiter 3, mode 3

Normally it is the function No torque limitation that is used. This means that the engine does not have any special restrictions.

Torque limiters 1,2 and 3 are activated by earthing a pin on connector C107 or C271.

For a description of how the engine reacts when each function is activated, see next page.

No torque limitation (mode 0)

When the No torque limitation function is connected, the engine torque curve is normal - no special limits are activated.

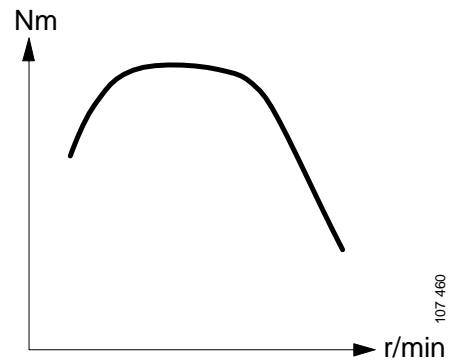

Torque limiter 1 (mode 1)

When the Torque limiter 1 function is activated, the torque curve of the engine is traditionally peaked. This torque curve may give the sensation that the pulling power increases when the engine speed decreases, i.e. on an uphill slope.

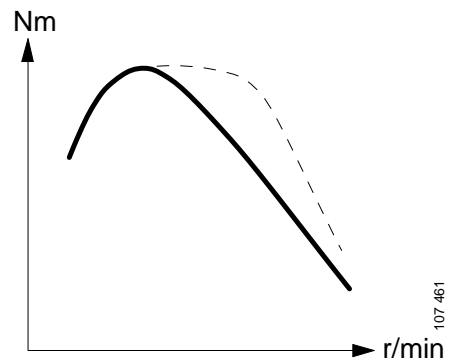

Torque limiter 2 (mode 2)

The Torque limiter 2 function limits the engine torque to 700 Nm for engine speeds up to 1000 rpm. At higher engine speeds, the torque limit decreases slightly.

The function is used on vehicles equipped with a torque converter with gear-changing clutch combined with a manual gearbox. It should be connected so that the function is active when the clutch pedal is depressed. This function is to protect the clutch against overheating.

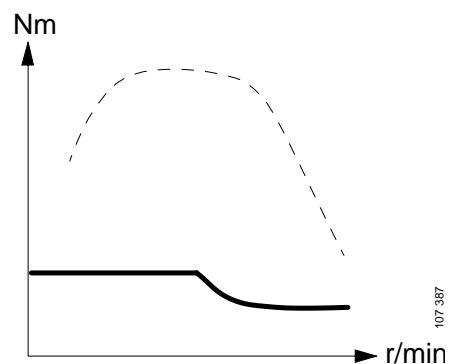

Torque limiter 3 (mode 3)

The Torque limiter 3 function gives a torque curve with a so called early breakaway. The engine torque begins to decrease at 1000 rpm and disappears completely at 1400 rpm. The function can be used as an alternative to the engine speed control function Limited hand throttle if one wants to protect a power take-off for example.

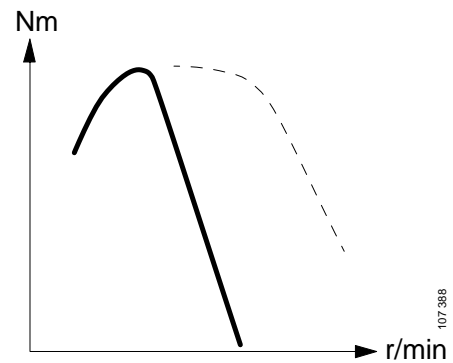

Customised torque curve

The Scania Programmer can be used to program a customised torque curve.

A programmed customised torque curve can be used to limit both torque and engine speed. It can be used to obtain a maximum engine speed to protect a power take-off for example. Unlike other functions, this function is **not** switched off when the brake or clutch pedal is depressed. The torque is set to 0 Nm to limit the engine speed. If you wish to limit the engine speed to 1000 rpm, for example, the torque is set to 0 Nm from 1000 rpm onwards.

The option to program a customised torque curve has been introduced from 02.98 for MS5.

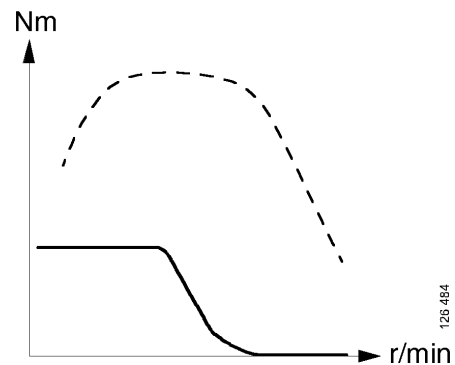

Speed limit

It is possible to programme two different speed limits: Maximum speed and Speed limit 2. The speed limits are programmed using Scania Programmer.

Below is a more detailed description of the two speed limits.

Maximum speed

The EDC control unit continuously receives information about the vehicle speed from the tachograph. When the maximum speed is reached, the control unit cuts in and limits throttle actuation so that the speed is maintained.

When driving at the set maximum speed, it is possible to temporarily increase the engine speed if the clutch pedal is depressed. This function is present to facilitate downshifting while engine braking.

Speed limit 2

Speed limit 2 means that it is possible - using Scania Programmer - to pre-set a speed limit that is lower than the maximum speed. The lower speed limit can, for example, be used in refuse vehicles fitted with an external platform. Speed limit 2 can then be activated when someone is standing on the platform.

The default value for Speed limit 2 is 70 km/h when a new EDC control unit is installed in a vehicle.

Work description

Connecting the special functions

Vehicle without coordinator

In trucks, the special functions are connected by earthing the pins onto connector C107 which is located below the central electric unit. C107 is connected to the EDC control unit. C107 is a blue 5-pin connector complete with both contact housings factory fitted.

Voltage is supplied to one of the control unit pins for the Speed limit 2 function.

- Voltage is supplied to control unit pin 50 for vehicles with EDC MS5.
- Voltage is supplied to the control unit pins via connector C112 at the cab inlet for vehicles with EDC MS6.

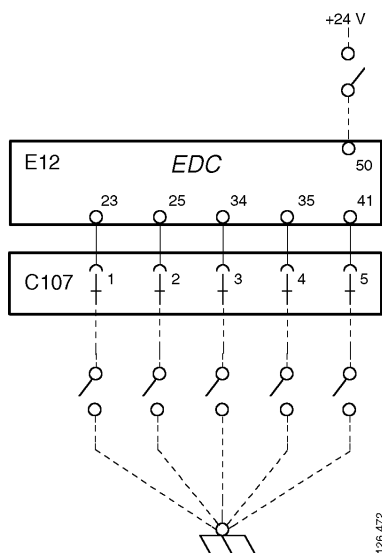
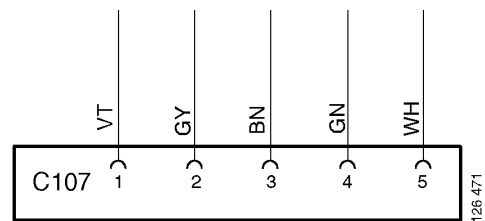
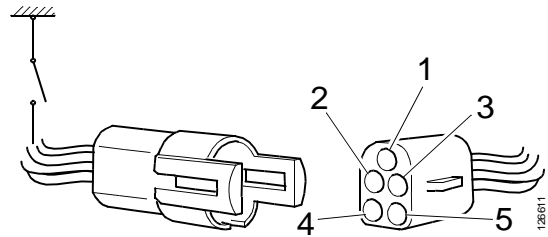

Circuit diagram for special functions on trucks with EDC MS5. For buses - refer to wiring diagram in Workshop Manual group 16.

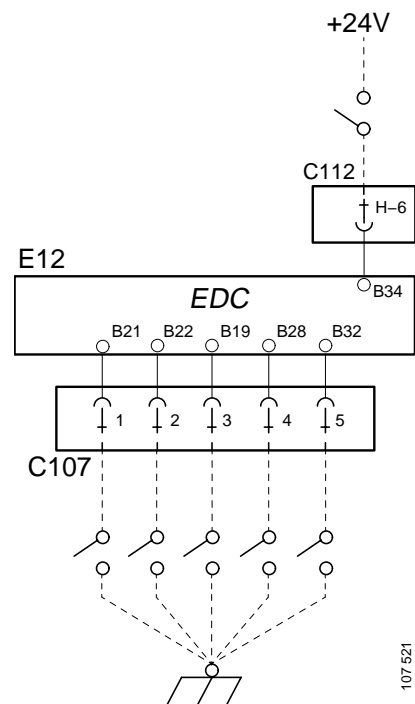

Circuit diagram for special functions on trucks with EDC MS6. For buses - refer to wiring diagram in Workshop Manual group 16.

Use the following parts when connecting:

- Cable terminal (pin), part no. 199 950
(C107)
- Cable terminal (pin), part no. 815 844
(C112)
- Cables with cross-section 0.75 mm²

The pins and connectors to which the cables are drawn to activate each special function can be seen below.

The table applies to trucks only. Refer to the bus wiring diagram if you are connecting cables on a bus.

| Special function | Connector pin |
|-------------------------|----------------------------|
| Emergency stop | C107, pin 2 |
| Limited hand throttle | C107, pin 1 |
| Raised idling speed | C107, pin 5 |
| Fixed engine speed | C107, pin 1+5 |
| Torque limiter 1 | C107, pin 4 |
| Torque limiter 2 | C107, pin 3 |
| Torque limiter 3 | C107, pin 3+4 |
| Speed limit 2 (EDC MS6) | C112, pin H-6 |
| Speed limit 2 (EDC MS5) | Control unit pin 50 |

Vehicle with coordinator

In trucks, the special functions are activated by earthing the pins onto connector C271 which is located in the central electric unit. C271 is connected to the Coordinator. C271 is a blue 6-pin connector complete with both contact housings factory fitted.

Use the following parts when connecting:

- Cable terminal (sleeve), part no. 815 886
- Cables with cross-section 0.75 mm²

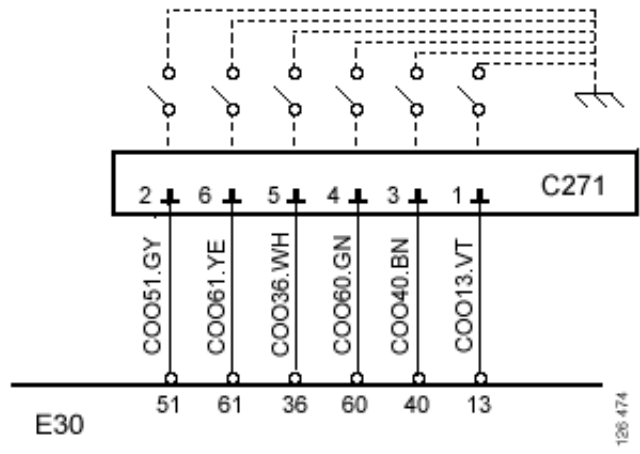
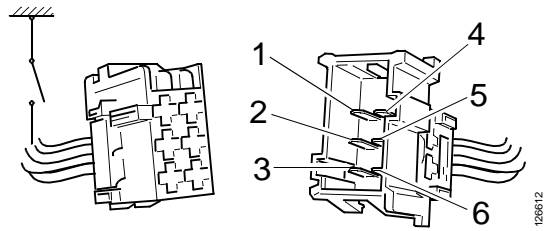

cardiagn.com

The pins and connectors to which the cables are drawn to activate each special function can be seen below.

The table applies to trucks only.

| Special function | Connector pin |
|-------------------------|----------------------|
| Emergency stop | C271, pin 2 |
| Limited hand throttle | C271, pin 1 |
| Raised idling speed | C271, pin 5 |
| Fixed engine speed | C271, pin 1+5 |
| Torque limiter 1 | C271, pin 4 |
| Torque limiter 2 | C271, pin 3 |
| Torque limiter 3 | C271, pin 3+4 |
| Speed limit 2 | C271, pin 6 |

Overview of functions

| Function | Pin on C107 | Pin on C271 | Programmed with SP |
|---|-------------|-------------|--------------------|
| Emergency stop | 2 | 2 | No |
| Limited hand throttle | 1 | 1 | |
| - Maximum engine speed | | | Yes |
| - Maximum torque | | | Yes |
| - Accelerator pedal, Active or Inactive | | | Yes |
| Raised idling speed | 5 | 5 | No |
| Fixed engine speed | 1+5 | 1+5 | |
| - Fixed engine speed | | | Yes |
| - Maximum torque | | | Yes |
| Torque limiter 1 | 4 | 4 | No |
| Torque limiter 2 | 3 | 3 | No |
| Torque limiter 3 | 3+4 | 3+4 | Yes |
| Speed limit 2 | * | 6 | Yes |

* Voltage is supplied to control unit pin 50 at +24 V for vehicles with EDC MS5.

Voltage is supplied to pin H6 on C112 for EDC MS6.

External engine control

In certain cases, it may be necessary to operate the engine speed control externally using controls corresponding to the cruise control ON, OFF, ACC, RET and RES. The external control is activated as shown in the wiring diagram in workshop manual 16:04-57, External engine control.

IMPORTANT! The connection must be made exactly as shown in the wiring diagram.

The external control should only be enabled when the parking brake is applied.

The cables to the external control must also be twisted to avoid interference.

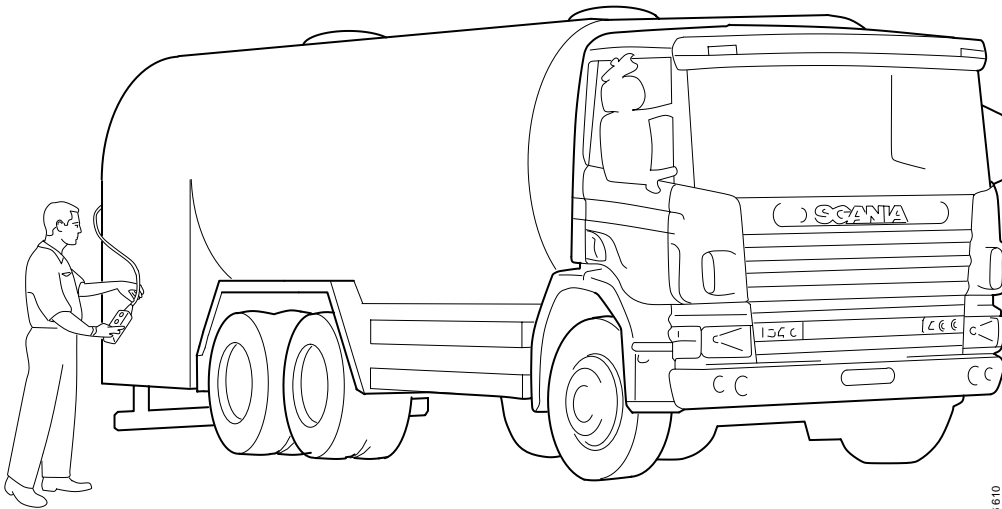

116 610