

SCANIA

03:04-01

Issue 3 en

Fuel system with unit injector PDE and EDC MS6

Work description

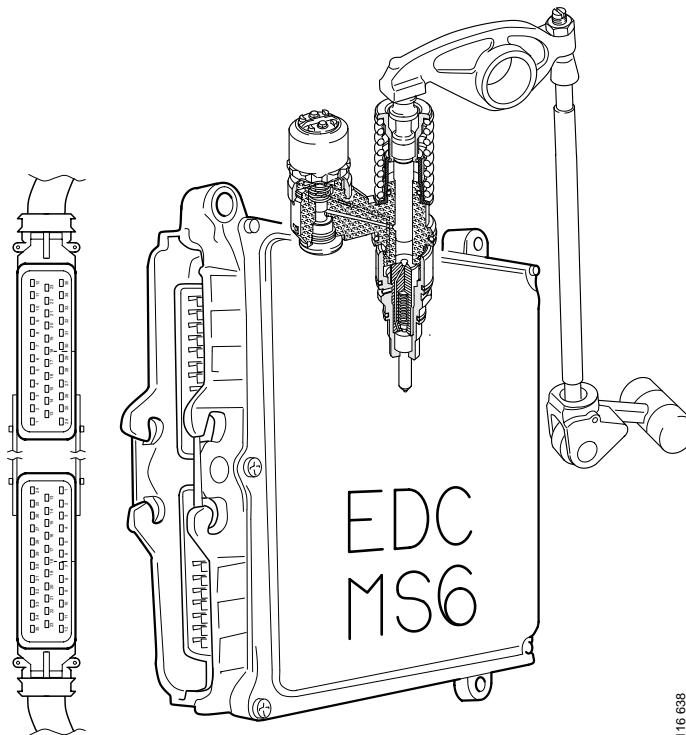

116 638

cardiagn.com

Contents

Components in the fuel system	Removing the unit injector	3
	Removing the unit injector, T cab with 16 litre engine	7
	Fitting the unit injector	12
	Fitting the unit injector, T cab with 16 litre engine	15
	Adjusting the unit injector with tool 99 365	18
	Adjusting the unit injector with tool 99 414	20
	Order of adjustment for unit injector.....	23
	Feed pump	25
Fuel filter	Removing the fuel filter on 11 and 12 litre engines.....	27
	Fitting	28
	Water separating prefilter	29
	Removing the fuel filter on 16 litre engines.....	30
	Fitting	31
Bleeding and pressure measuring the fuel system	Bleeding 11 and 12 litre engines	32
	Bleeding 16 litre engines.....	33
	Measuring feed pump pressure	34
	Overflow valve	36
EDC cables	Removing the cables	38
	Fitting the cables	42
	Repairing the EDC cables	50
EDC control unit	Renewing the control unit	55

Components in the fuel system

Removing the unit injector

Special tools

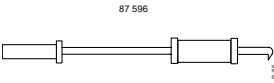
Number	Description	Illustration	Tool board
99 309	Tool to rotate flywheel		D5
87 596	Slide hammer		D2

- 1 Open the bleeder nipple and drain the fuel system by undoing the banjo screw/unions on the back of the fuel manifold.



WARNING!

The fuel system must be empty or fuel may run down into the cylinders, which will result in a great risk of liquid hammering.

If fuel runs into the combustion chamber, it must be removed immediately using a pump.

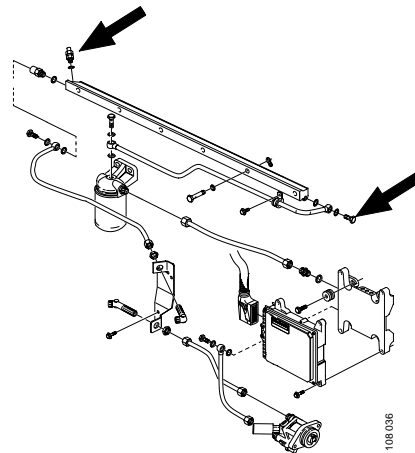

12 litre engine

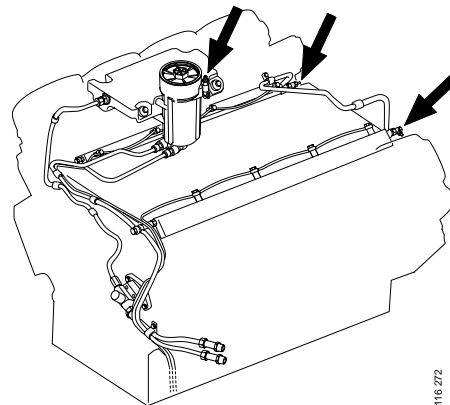

16 litre engine

- 2 Clean the rocker cover and the surrounding area.
- 3 Remove the top part of the rocker cover.
- 4 Relieve the pressure on the valves by undoing the bolts on the rocker arm shaft alternately.



WARNING!

Do not lean over the engine when removing the rocker arm shaft. The unit injector spring is pre-tensioned and can come loose, causing personal injury.

Note: If the spring comes loose from the unit injector, the unit injector must be renewed.

- 5 Remove the rocker arm shaft.

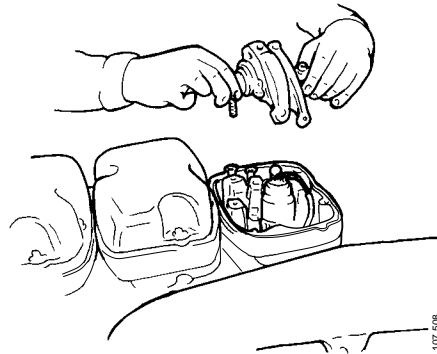

- 6 Remove the fork clamp bolt holding the unit injector in place.

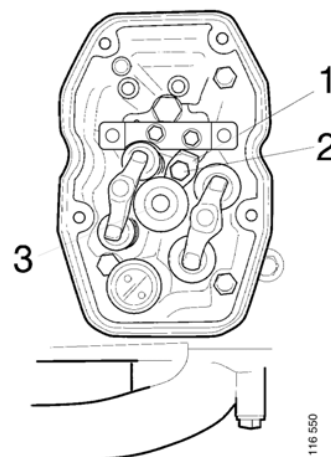

- 1 Fork clamp
- 2 Fork clamp bolt
- 3 Unit injector

- 7 Detach the cables on the unit injector. The screws cannot be removed but unscrew them as far as possible.

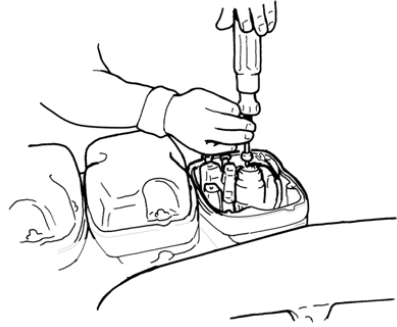

Note: Do not lift the unit injector by the spring. The spring can come loose.

- 8 Turn the unit injector anti-clockwise until it stops. Place the slide hammer 87 596 between the solenoid valve and the edge of the lower rocker cover as illustrated.

Note: If the slide hammer is placed directly under the solenoid valve, there is a risk of breaking the solenoid valve.

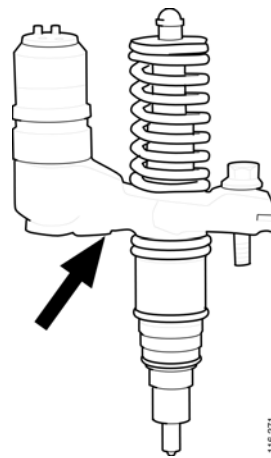

Place the slide hammer as indicated by the arrow.

- 9 It is easier to position the slide hammer if one of the lower rocker cover bolts is removed.

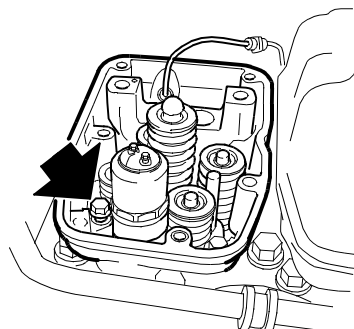

- 10 Withdraw the unit injector. If the unit injector is stuck, tap carefully with a rubber mallet on the solenoid valve housing.

IMPORTANT! The unit injector is not to be dismantled. Renew the entire unit.

- 11 Remove the sealing washer from the bottom of the injector seat, (if it was left behind when the unit injector was removed).

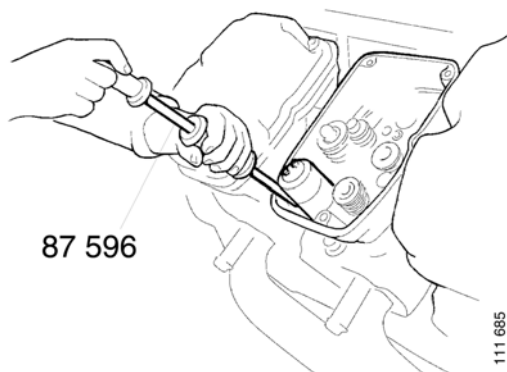

Removing the unit injector, 16 litre engine with T cab

On vehicles with a T cab and 16 litre engine, there is not much space between the rear cylinders 3, 4, 7, 8 and cab when removing unit injectors. The cab must be raised and supported at the front with stands when removing unit injectors.

- 1 Raise the cab to its maximum position by disconnecting the lever and pushing the lever upwards.

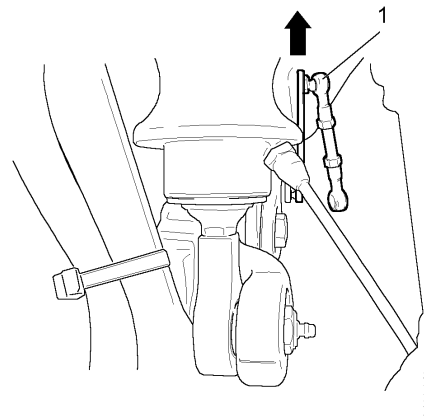

1 Cab suspension lever

- 2 Fit engine support 99 318 with socket, 100 millimetres between the cab bracket and anti-roll bar attachment. Unscrew the engine support so that the tip goes down into the bolt hole and the tool is secure.

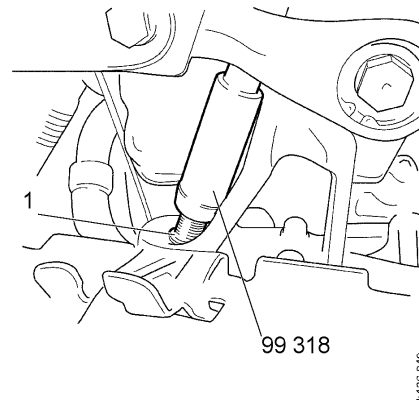

1 Engine support 99 318.

- 3 Clean the rocker cover and the surrounding area.
- 4 Remove the top part of the rocker cover. On cylinders 3 and 7, the rocker cover must be angled to get it past the cab bracket.

- 5 Relieve the pressure on the valves by undoing the bolts on the rocker arm shaft alternately.



WARNING!

Do not lean over the engine when removing the rocker arm shaft. The unit injector spring is pre-tensioned and can come loose, causing personal injury.

Note: If the spring comes loose from the unit injector, the unit injector must be renewed.

- 6 Remove the rocker arm shaft.

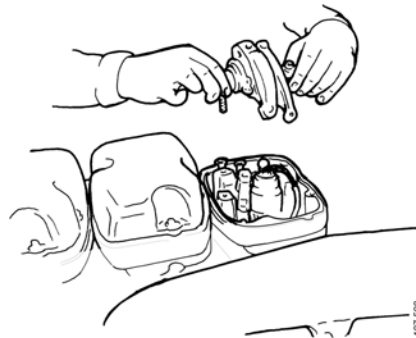

Note: When working on cylinders 3 and 7, the lower rocker cover must also be removed to leave space for slide hammer 87 596.

- 7 Remove the bearing bracket. Applies to cylinders 3 and 7.

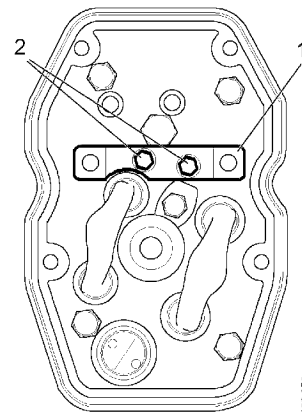

- 1 *Bearing bracket*
- 2 *Bearing bracket bolt*

- 8 Unscrew screw 1 holding the cable inlet for the unit injector in the lower rocker cover. Applies to cylinders 3 and 7.

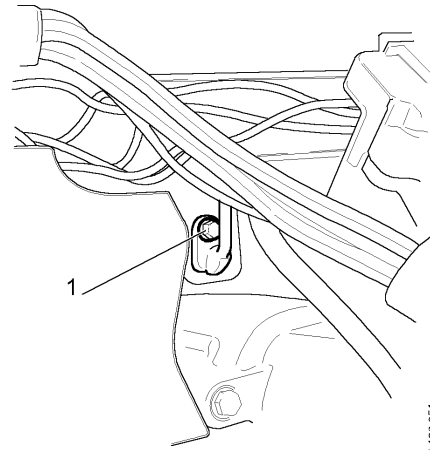

b128 051

1 Screw for inlet

- 9 Detach the cables on the unit injector. The screws cannot be removed but unscrew them as far as possible. Remove the cable through the hole in the lower rocker cover.

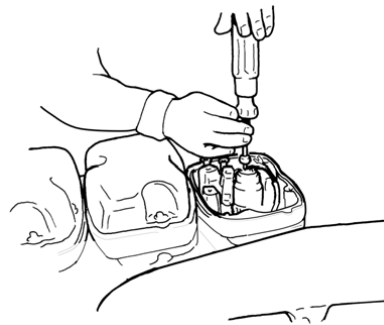

007 510

- 10 Remove the lower rocker cover bolts and remove the lower rocker cover.

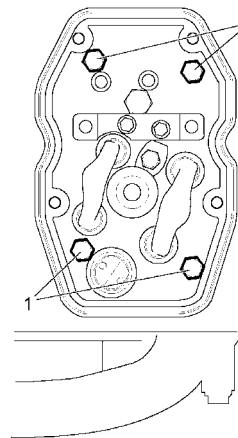

b128 026

1 Bolt for lower rocker cover

Note: Do not lift the unit injector by the spring. The spring can come loose.

- 11 Remove the fork clamp bolt holding the unit injector in place.

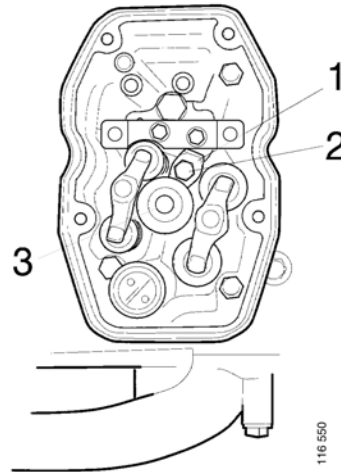

- 1 Fork clamp
- 2 Fork clamp bolt
- 3 Unit injector

- 12 Turn the unit injector clockwise until it stops. Place the slide hammer 87 596 between the solenoid valve and the edge of the lower rocker cover as illustrated.

Note: If the slide hammer is placed directly under the solenoid valve, there is a risk of breaking the solenoid valve.

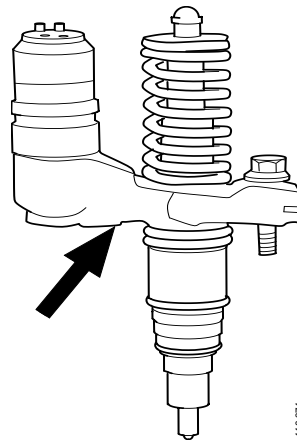

Place the slide hammer as indicated by the arrow.

- 13 Withdraw the unit injector. If the unit injector is stuck, tap carefully with a rubber mallet on the solenoid valve housing.

IMPORTANT! The unit injector is not to be dismantled. Renew the entire unit.

- 14 Remove the sealing washer from the bottom of the injector seat, if it was left behind when the unit injector was removed.

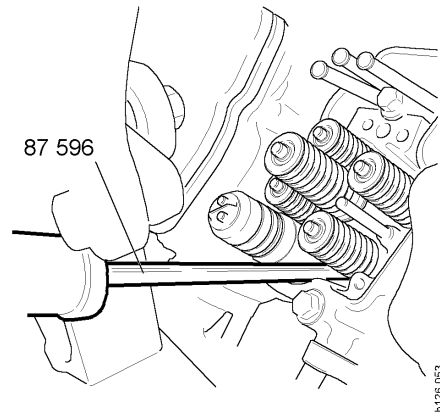

Fitting the unit injector

Specifications

Dimension for unit injector (cold engine) 66.9+/-0.1 mm

Description	Part no.
O-ring grease for unit injector O-rings	1 402 039

Tightening torque

Lock nut on rocker arm	39 Nm
Bolt for fork on unit injector	20 Nm + 75°
Bearing bracket and rocker arm shaft	105 Nm
Screws for cable connections on unit injector	2 +/-0.2 Nm

Special tools

Number	Description	Illustration
588 179	Torque screwdriver	

Note: All work that involves opening the fuel system must be completed in the following way:

Start the engine and check for leaks. Allow the engine to run until it is running smoothly.

Check and delete any fault codes that arise in the control unit using Scania Diagnos after the work has been completed.

- 1 Make sure that the old sealing washer is not at the bottom of the injector seat. Clean the sealing surfaces in the injector seat.

IMPORTANT! Always renew the O-rings and sealing washer on unit injectors that have been removed. Make sure all sealing surfaces are clean.

- 2 Lubricate the unit injector O-rings with O-ring grease, part No. 1 402 039.
- 3 Fit a new sealing washer on the unit injector. A rubber insert will keep the sealing washer in place on the unit injector.

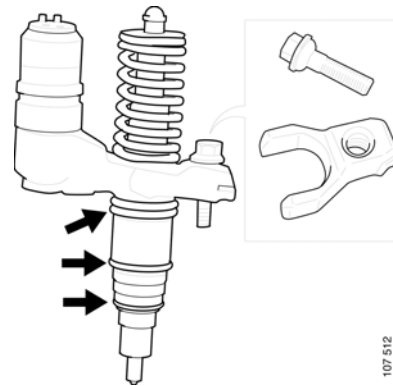

- 4 Place the fork clamp with bolt in position on the unit injector and insert it into the cylinder head. Press down the unit injector by hand as far as possible.

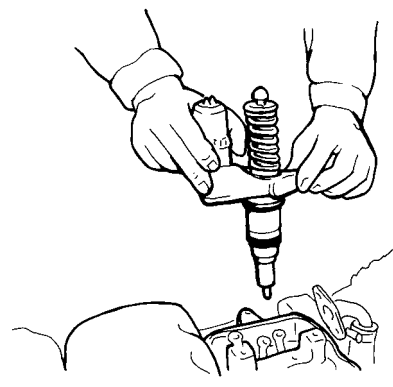

Note: Make sure that the fork clamp and bolt are dry and free of oil.

- 5 Torque tighten the bolt to 20 Nm and then a further 75°. There are two marks on the rocker cover with a 75° angle between them.

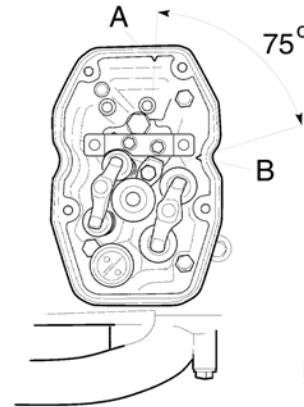
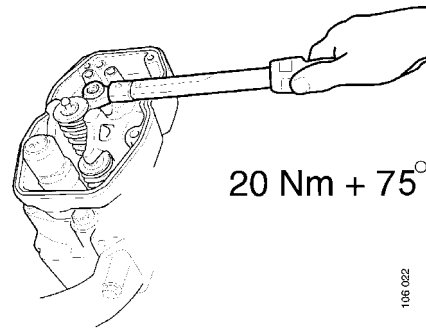

IMPORTANT! Make sure the pushrods are placed in their correct positions. Make sure the pushrod to the unit injector is firmly secured in its lower position by the snap ring.

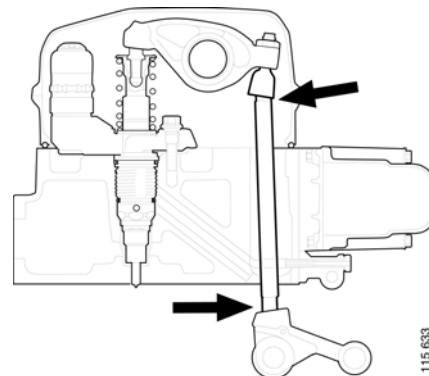

IMPORTANT! If the rocker arms have been removed on more than one cylinder, the rocker arm lock bolts must be completely unscrewed before adjustment commences.

- 6 Refit the rocker arm shaft. Screw in the bolts alternately so that they are tightened in parallel or one of the bolts may bend. Torque tighten the bolts to 105 Nm.
- 7 Adjust the unit injector as described in Adjusting the unit injectors.

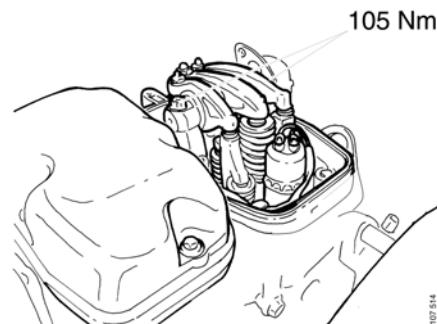

Fitting the unit injector, 16 litre engine with T cab

- 1 Fit the lower rocker cover. Tighten the bolts to 26 Nm.

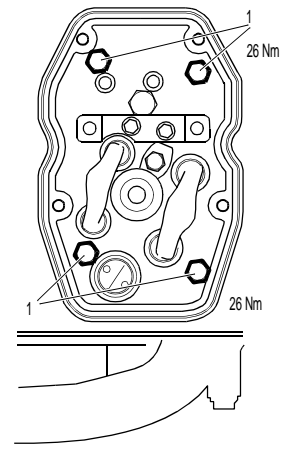

1 Bolt for lower rocker cover

- 2 Pull the unit injector cable through the hole in the lower rocker cover and fit inlet screw 1.
- 3 Make sure that the old sealing washer is not at the bottom of the injector seat. Clean the sealing surfaces in the injector seat.

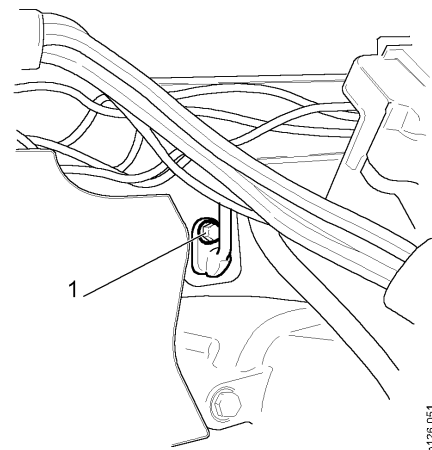

1 Screw for inlet

IMPORTANT! Always renew the O-rings and sealing washer on unit injectors that have been removed. Make sure all sealing surfaces are clean.

- 4 Lubricate the unit injector O-rings with O-ring grease, part No. 1 402 039.

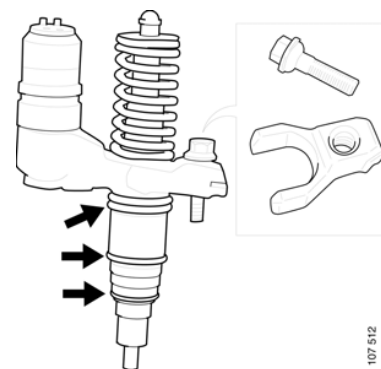

107 512

- 5 Fit a new sealing washer on the unit injector. A rubber insert will keep the sealing washer in place on the unit injector.
- 6 Clean the fork clamp and bolt before fitting.
- 7 Place the fork clamp with bolt in position on the unit injector and insert it into the cylinder head. Press down the unit injector by hand as far as possible.

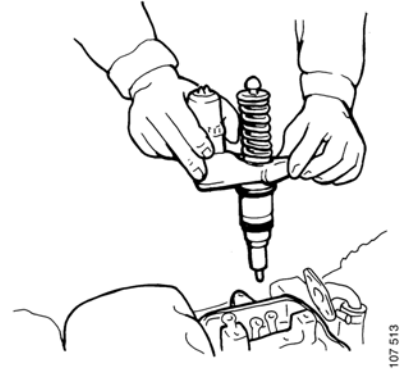

- 8 Torque tighten the bolt to 20 Nm and then a further 75°. There are two marks on the rocker cover with a 75° angle between them.

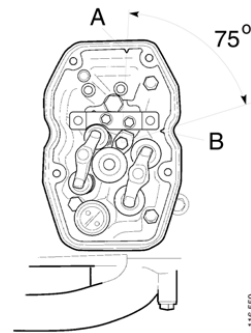
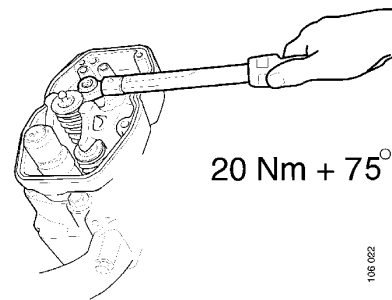

- 9 Fit the bearing bracket. Torque tighten the bolts to 105 Nm.

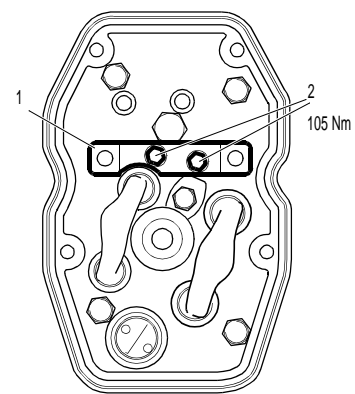

- 1 Bearing bracket bolt
- 2 Bearing bracket

IMPORTANT! Make sure the pushrods are placed in their correct positions. Make sure the pushrod to the unit injector is firmly secured in its lower position by the snap ring.

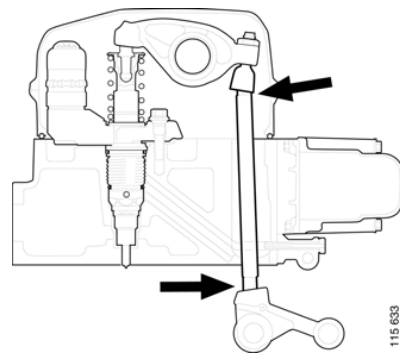

IMPORTANT! If the rocker arms have been removed on more than one cylinder, the rocker arm lock bolts must be completely unscrewed before adjustment commences.

10 Refit the rocker arm shaft. Screw in the bolts alternately so that they are tightened in parallel or one of the bolts may bend. Torque tighten the bolts to 105 Nm.

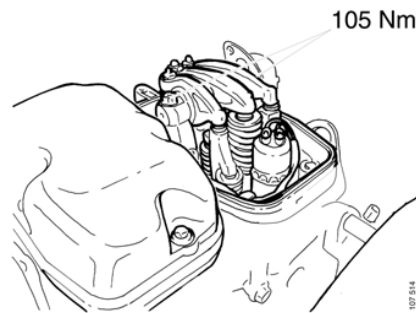

11 Remove engine support 99 318 with socket from the cab bracket.

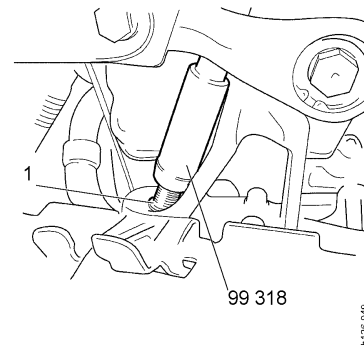

1 Engine support 99 318.

12 Refit the cab suspension lever.

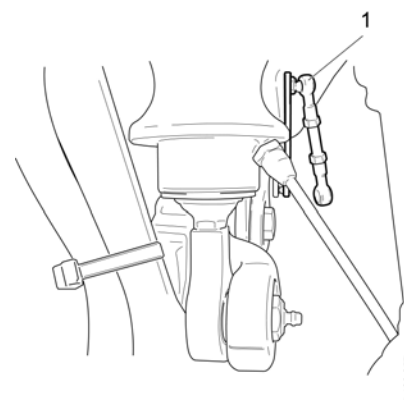

13 Adjust the unit injector as described in Adjusting the unit injectors.



1 Cab suspension lever.

Adjusting the unit injector with tool 99 365

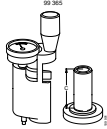
Special tools

Number	Description	Illustration	
99 365	Setting tool		Measuring tool cabinet
588 179	Torque screwdriver		

- 1 Start by rotating the flywheel so that the mark on it is visible in the **bottom** window according to the table below. Never read off the flywheel mark in the top window - this reading will be completely wrong.

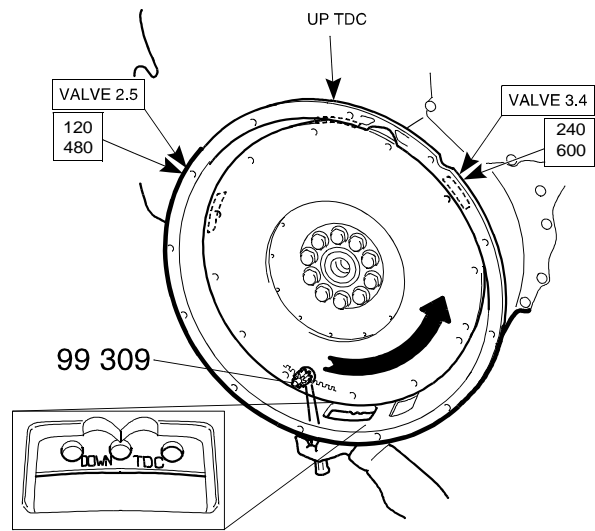

126 020

Adjusting the unit injectors

IMPORTANT! Adjust roughly first with a sliding caliper and then fine adjust using the setting tool 99 365. If both adjustments are not carried out, the unit injector may attain an incorrect position, which will result in poor performance and possible breakdown.

- 2 Screw on the rocker arm lock bolt 1 while measuring the distance between plane a and the top of the valve spring collar using a sliding caliper. The distance should be 66.9 mm.

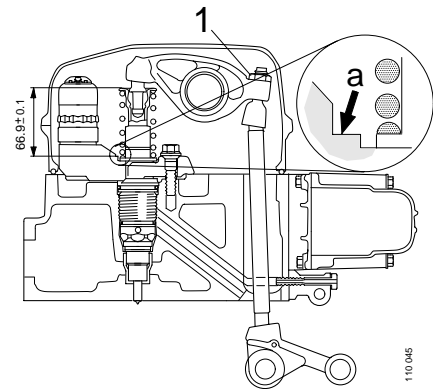

- 3 Place setting tool 1 (99 365) on reference gauge 2. Zero the setting tool by rotating the dial indicator 1A.

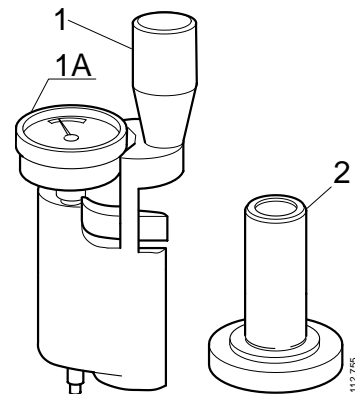

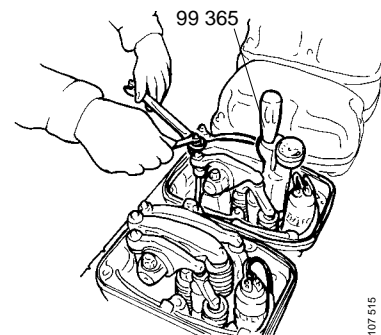

- 4 Finely adjust the unit injector so that the distance between plane a and the top of the valve spring collar is 66.9 +/- 0.1 mm.

Refer to tables in Order of adjustment for unit injector.



Adjusting the unit injector with tool 99 414

Special tools

Number	Description	Illustration	
99 414	Setting tool		Measuring tool cabinet
588 179	Torque screwdriver		

- 5 Fit adjusting tool 99 414 with the metal plate around the unit injector.

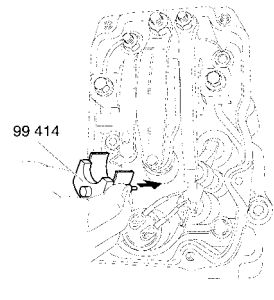

WARNING!

When the unit injector is checked and the measurement is outside 66.9+/-0.5 mm, it is necessary to be very careful when handling this unit injector. The spring is pre-tensioned and can come loose, causing personal injury.

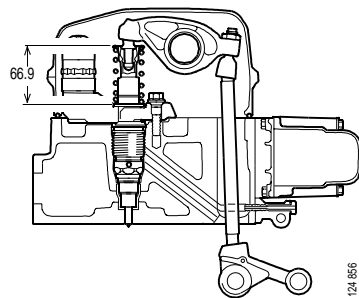

Setting tool 99 414 acts as a gauge with the measurement 66.9 mm.

- 6 When adjusting, undo the lock nut and adjust the unit injector with the adjusting screw 1. The unit injector is correctly set when the small piston 2 is level with the flat upper surface of the tool. Check using a finger. It is possible to feel differences of less than a millimetre. The setting dimension is 66.9 ± 0.1 mm.

Refer to tables in Order of adjustment for unit injector.

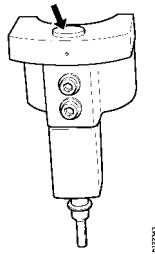
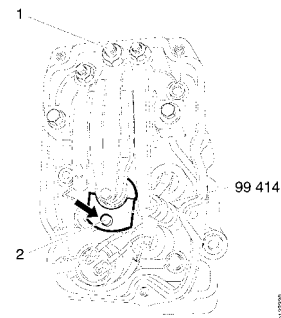

The setting tool piston is above or below the flat upper surface of the tool. Adjust the unit injector.

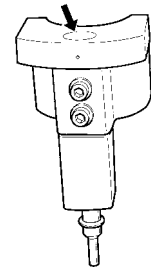

The setting tool piston is level with the flat upper surface of the tool. The unit injector is correctly adjusted.

- 7 Torque tighten the lock nut to 39 Nm after adjusting.
- 8 Remove tool 99 414.

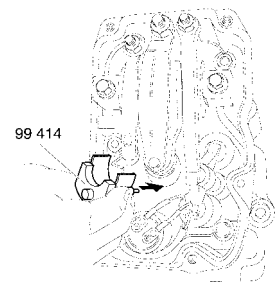

IMPORTANT! Fit the cables so that they face in the correct direction when fitting them on the unit injector.

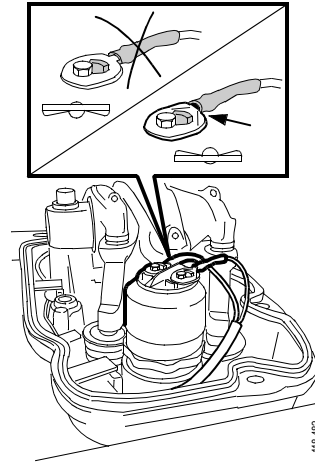

- 9 Reconnect the cables on the unit injectors. Their relative position is not important. Use torque screwdriver 588 179 to tighten the screws to 2 Nm.

IMPORTANT! Use torque screwdriver 588 179 to avoid the risk of shearing off the screws. The entire unit injector must be renewed if the screws shear off.

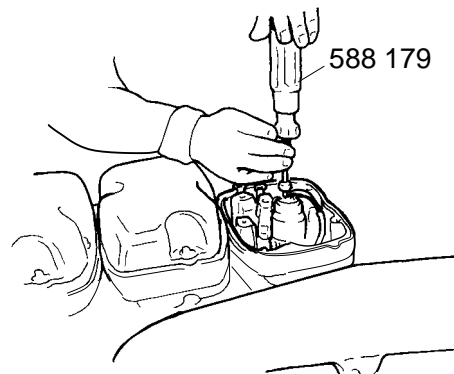

- 10 If the cables to the unit injector are too long, they can be clamped round the solenoid valve on the unit injector.
- 11 Refit the upper rocker cover and torque tighten the bolts to 12 Nm or 18 Nm depending on the type of bolt, refer to illustration.
- 12 Close the bleeder nipple and tighten the banjo screw.
- 13 Fill and bleed the fuel system, refer to Bleeding the fuel system.

18 ± 3Nm

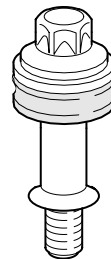

12 ± 3Nm

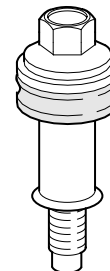

Order of adjustment for unit injector

Order of adjustment for 11 and 12 litre engines

Rotate the flywheel using tool 99 309 so that the mark on the flywheel is visible in the bottom window according to the table below.

Mark on flywheel (degrees)	Valve change on cylinder	Adjust injector rocker arm on cylinder	Adjust valves on cylinder
TDC Down (0°)	1	2	6
Valve 2, 5/ 120 480 (120°)	5	4	2
Valve 3, 4/ 240,600 (240°)	3	1	4
TDC Down (0°)	6	5	1
Valve 2, 5/ 120 480 (120°)	2	3	5
Valve 3, 4/ 240,600 (240°)	4	6	3

It is a good idea to mark the rocker arm with a pen after adjustment to keep track of what has already been adjusted.

Torque tighten the lock nut to 39 Nm after adjusting.

Order of adjustment for 16 litre engine

Rotate the flywheel using tool 99 309 so that the mark on the flywheel is visible in the bottom window according to the table below.

Mark on flywheel (degrees)	Valve change on cylinder	Adjust injector rocker arm on cylinder	Adjust intake valve on cylinder	Adjust exhaust valve on cylinder
TDC Down (0°)	6	4 and 5	7 and 8	4 and 5
TDC Up (180°)	7	2 and 6	1 and 5	2 and 6
TDC Down (360°)	1	3 and 7	2 and 4	3 and 7
TDC Up (540°)	4	1 and 8	3 and 6	1 and 8

It is a good idea to mark the rocker arm with a pen after adjustment to keep track of what has already been adjusted.

Torque tighten the lock nut to 39 Nm after adjusting.

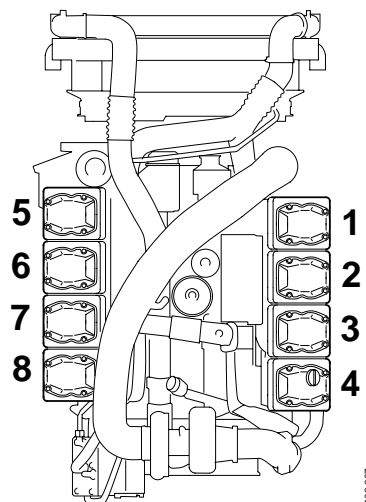

Cylinder numeration

Feed pump

Renewal

- 1 Unscrew the bolts and remove the feed pump.
- 2 Clean the outside of the feed pump. Remove the suction and pressure lines from the feed pump. Fit protective plugs.
- 3 Place a new O-ring onto the feed pump and lubricate with O-ring grease.
- 4 Fit the feed pump.
- 5 Connect the suction and pressure lines.
- 6 Bleed the fuel system, refer to Bleeding the fuel system.
- 7 Start the engine and check for leaks.

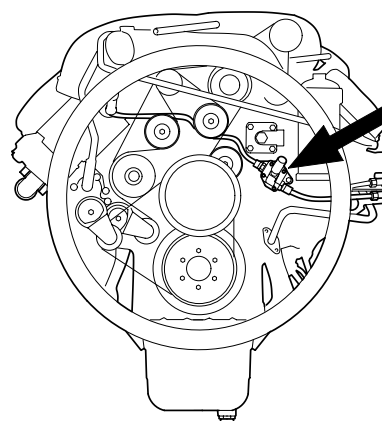
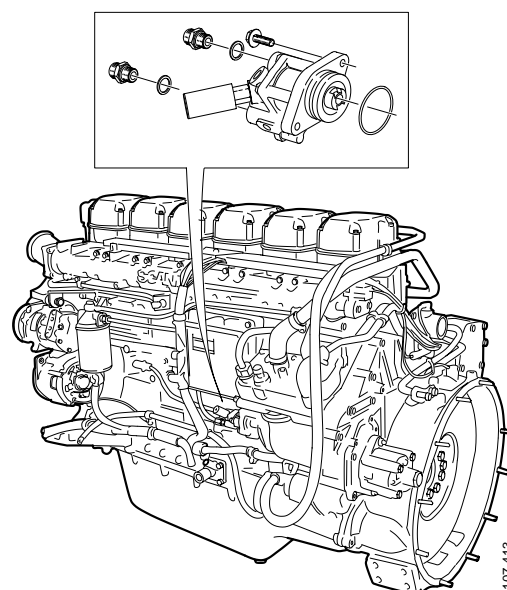

If the feed pump has been changed or if the pipes on the suction and pressure sides of the pump have been removed, the pump may not succeed in pumping the fuel. This is due to there still being fuel in the fuel filter.

- 1 Detach the inlet pipe to the filter and bend it downwards.

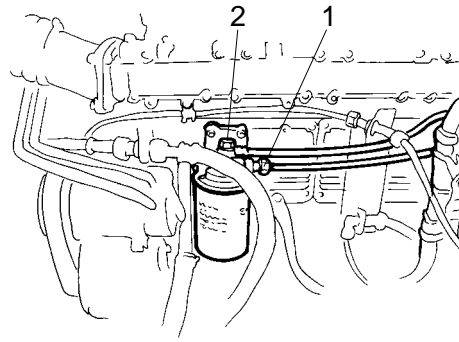

12 litre engine

- 1 Inlet pipe*
- 2 Outlet pipe*

- 2 Pump with the hand pump until resistance is felt and the fuel begins to run out of the pipe.
- 3 If this does not help, detach the outlet pipe from the feed pump at the point where it connects to the control unit cooler. Pump until fuel begins to run out of the pipe.
- 4 Bleed the fuel system, refer to Bleeding the fuel system.

Fuel filter

Removing the fuel filter on 11 and 12 litre engines

Special tools

Number	Description	Illustration	Tool board
587 025	Filter tongs		-

- 1 Wash the filter and the filter retainer.

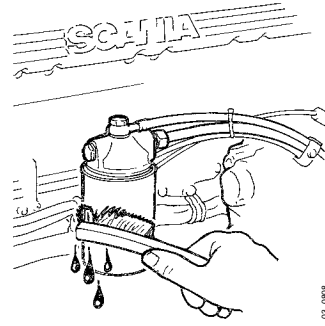

- 2 Unscrew the filter. Use filter tongs, e.g. 587 025.

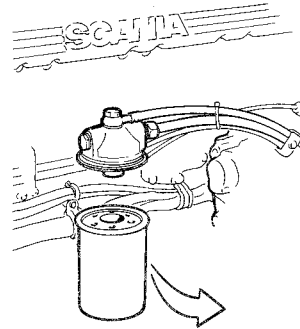

Fitting

Note: All work that involves opening the fuel system must be completed in the following way:

Start the engine and check for leaks. Allow the engine to run until it is running smoothly.

Check and delete any fault codes that arise in the control unit using Scania Diagnos after the work has been completed.

IMPORTANT! Engines with unit injectors must be fitted with fuel filters marked **HIGH PERFORMANCE**.

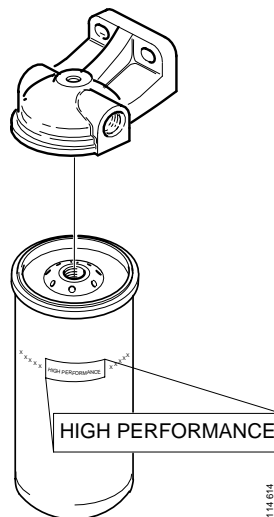

- 1 Oil the filter O-ring.
- 2 Screw on the new fuel filter by hand until the O-ring is against the filter retainer.
- 3 Then tighten it another half turn without using any tools.
- 4 Check for correct sealing.
- 5 Fill the fuel system and bleed as described in Bleeding the fuel system.

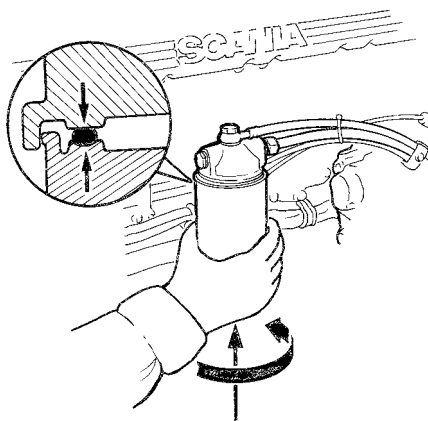

Water separating prefilter

Some vehicles are equipped with an additional water separating fuel filter attached to the chassis.

Note: Close the shut-off cock when renewing the filter.

The same intervals between changes apply as for those for an ordinary fuel filter.

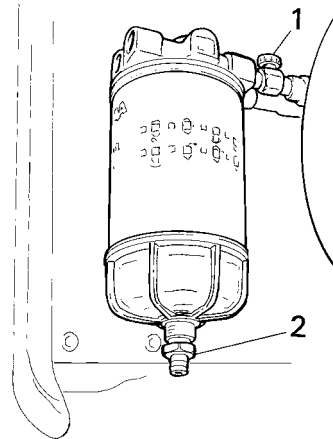

- 1 Shut-off cock
- 2 Drain valve

Removing the fuel filter on 16 litre engines

Special tools

Number	Description	Illustration	Tool board
588 475	Sleeve		Maintenance cabinet

- 1 Unscrew the filter cover with a closed tool with hexagon driver, e.g. socket 588 475.

Note: Do not use an adjustable spanner or other open tool as there is a risk of damaging the filter cover.

- 2 Lift out the filter cover with filter element from the fuel filter housing. The filter housing will drain automatically once the filter element has been removed.

Note: Contaminated fuel will enter the injectors if the drainage does not work.

- 3 Undo the old filter element from the cover by carefully bending it to one side.

Fitting

Tightening torque

Fuel filter cover

25 Nm+/- 5 Nm

Note: All work that involves opening the fuel system must be completed in the following way:

Start the engine and check for leaks. Allow the engine to run until it is running smoothly.

Check and delete any fault codes that arise in the control unit using Scania Diagnos after the work has been completed.

- 1 Fit a new O-ring on the cover. Lubricate the O-ring with O-ring grease.
- 2 Make sure the fuel filter drain has emptied the fuel from the filter housing.

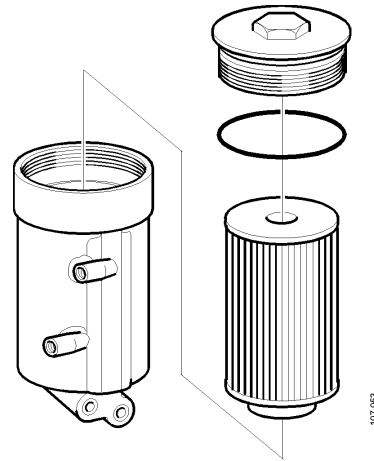

Note: Contaminated fuel will enter the injectors if the drainage does not work.

- 3 Press a new filter element into the snap fastener in the cover.

IMPORTANT! Fit the filter element into the cover before placing it in the housing or the filter element might be damaged.

- 4 Press down the filter element into the housing with the cover. Torque tighten the cover to 25 Nm+/-5 Nm.

IMPORTANT! Screw on the cover to the specified torque or the filter element may break.

- 5 Fill the fuel system and bleed as described in Bleeding the fuel system.

Bleeding and pressure measuring the fuel system

Bleeding 11 and 12 litre engines

- 1 Attach a clear plastic hose to the bleeder nipple at the front of the fuel manifold.
- 2 Open the bleeder nipple and pump with the hand pump until fuel comes out of the hose.
 - If the system is completely empty, it will take approximately 250 strokes.
 - After renewing the fuel filter, it will take approximately 170 strokes.
 - Approximately 150 strokes are required to bleed the fuel manifold.
- 3 Pump an additional 20 strokes to remove the air.
- 4 Close the bleeder nipple and remove the hose. Pump with the hand pump until the overflow valve opens, approximately 20 strokes.
- 5 Start the engine and check for leaks.

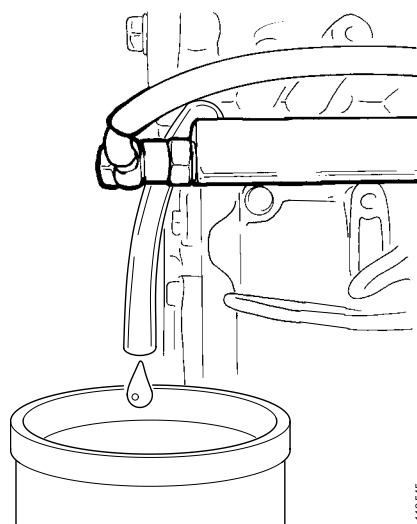

118545

Bleeding 16 litre engines

- 1 Attach a clear plastic hose to the bleeder nipple on the fuel filter housing.
- 2 Open the bleeder nipple and pump with the hand pump until fuel comes out of the hose.
- 3 Close the bleeder nipple and remove the hose.
- 4 Continue pumping by hand until a resistance is felt, which will be after approximately:
 - 20 pump strokes after renewing the fuel filter.
 - 50 pump strokes after renewing a unit injector.
- 5 Start the engine and check for leaks.

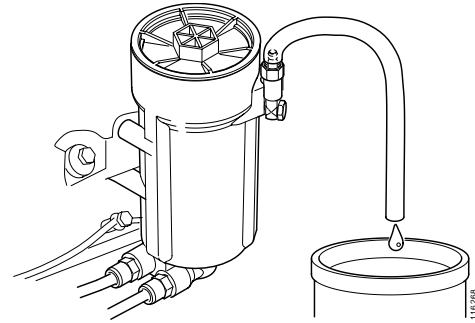

Note: If the engine is difficult to start, repeat steps 2-4 a few times.

IMPORTANT! Do not crank with the starter motor for longer than 30 seconds at a time.

Measuring feed pump pressure

Specifications

Lowest permitted fuel pressure at 1900 rpm	5.5 bar
Lowest permitted fuel pressure at 500 rpm	4.5 bar

Special tools

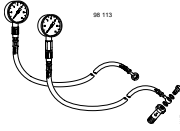
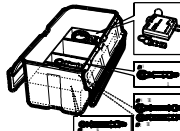
Number	Description	Illustration	Tool board
98 113	Pressure gauge		D6
99 362	Pressure gauge		

Note: All work that involves opening the fuel system must be completed in the following way:

Start the engine and check for leaks. Allow the engine to run until it is running smoothly.

Check and delete any fault codes that arise in the control unit using Scania Diagnos after the work has been completed.

Two different pressure gauges can be used for measuring the pressure. Pressure gauge 98 113 or pressure gauge 99 362. User instructions for pressure gauge 99 362 can be found in booklet 01:00-03.

Renew the fuel filter and bleed the fuel system before measuring.

The pressure is maintained by the overflow valve.

Inspect fuel lines with connections, overflow valve, fuel filter and feed pump if the fuel pressure is too low.

11 and 12 litre engines

- 1 Connect the pressure gauge to the fuel filter outlet connection.

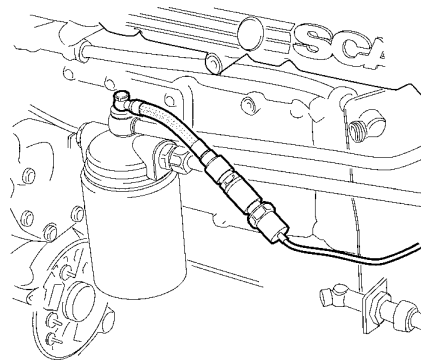

Connecting pressure gauge 99 362 to a 12 litre engine

16 litre engine

- 1 Connect the pressure gauge to the union on the fuel filter.

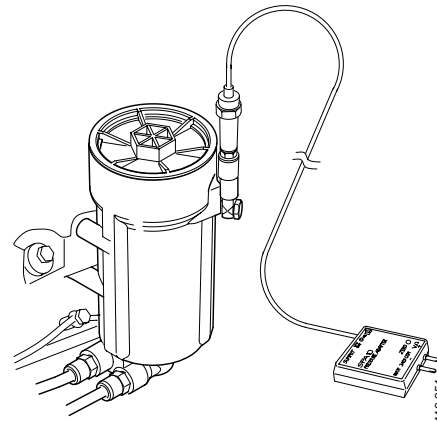

Connecting pressure gauge 99 362 to a 16 litre engine

All

- 2 Start the engine and rev it up to 500 rpm. Take a pressure reading; the lowest permitted fuel pressure at 500 rpm is 4.5 bar.
- 3 Rev up the engine to 1900 rpm. Take a pressure reading; the lowest permitted fuel pressure at 1900 rpm is 5.5 bar.

The pressure is maintained by the overflow valve.

Inspect fuel lines with connections, overflow valve, fuel filter and feed pump if the fuel pressure is too low.

Overflow valve

Check

Specifications

Lowest permitted fuel pressure	4.5 bar
Highest permitted fuel pressure	7.5 bar

Special tools

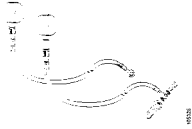
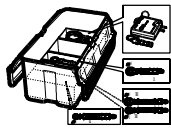
Number	Description	Illustration	Tool board
98 113	Pressure gauge		D6
99 362	Pressure gauge		

Note: All work that involves opening the fuel system must be completed in the following way:

Start the engine and check for leaks. Allow the engine to run until it is running smoothly.

Delete any fault codes that have arisen in the control unit using Scania Diagnos when the work has been completed.

Two different pressure gauges can be used for measuring the pressure. Pressure gauge 98 113 or pressure gauge 99 362. User instructions for pressure gauge 99 362 can be found in booklet 01:00-03.

The pressure is maintained by the overflow valve.

11 and 12 litre engines

- 1 Connect the pressure gauge to the fuel filter outlet connection.

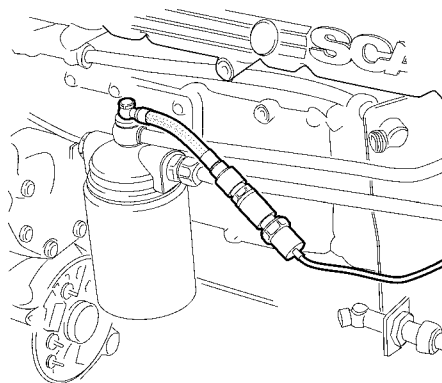

16 litre engine

- 1 Connect the pressure gauge to the back of the left-hand fuel manifold.

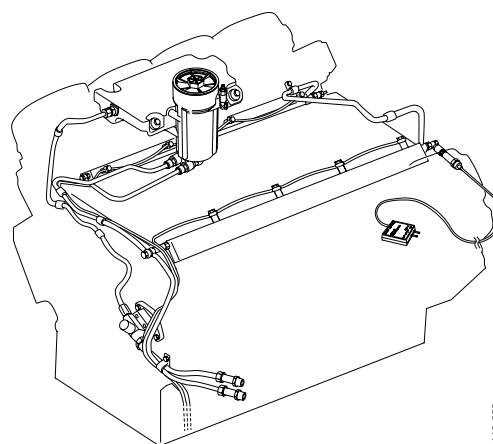

All

- 2 Turn the starter key to the drive position.
- 3 Pump by hand using the hand pump. The pressure must be at least 4.5 bar before the overflow valve opens; if the overflow valve opens at a lower pressure, its opening pressure is too low and the valve must be renewed.
- 4 Start the engine and rev it up to 1500 rpm.
- 5 Take a pressure reading; if the pressure is 7.5 bar or above, the overflow valve is blocked and must be cleaned or renewed.

EDC cables

Removing the cables

- 1 Drain the coolant from the engine as instructed in the work description for the cooling system.
- 2 Wash clean the rocker covers and the surrounding areas.

- 3 16 litre engine: Remove the inlet pipe between the turbocharger and the air cleaner.
- 4 16 litre engine: Remove the air line to the compressor. The air line is located on the left-hand cable duct.

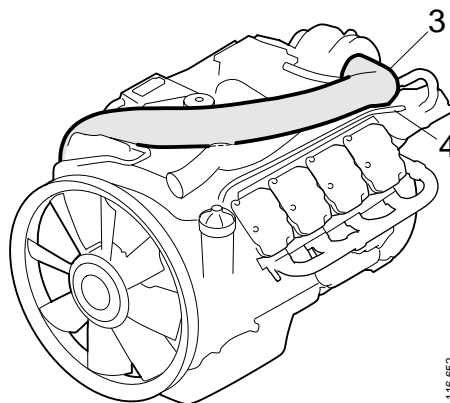

116 652

- 5 Unplug the two control unit connectors.
- 6 Remove the rocker covers. The crankcase ventilation must be loosened on 11 and 12 litre engines to be able to remove the rocker cover on cylinder 1.

- 7 Detach the cables from the unit injectors.
The screws cannot be removed but unscrew them as far as possible.
- 8 Mark the cables with the respective cylinder number.

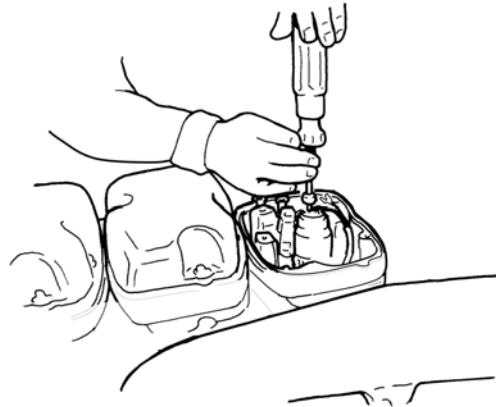

- 9 16 litre engine: Unscrew the grommets from the lower rocker covers. Then pull out the cables from the rocker covers and lift off the cable ducts.

11 and 12 litre engines: Detach the cable duct on which the cables are fastened. Then unscrew the cable grommets in the lower rocker covers and remove the cables.

- 10 Remove the charge air sensor and its clamps.
- 11 16 litre engine: Separate the connector on the fan ring that is connected to the electrically controlled fan solenoid valve. Also remove the cable clamps.
- 12 16 litre engine: Remove the oil pressure sensor and its clamps.
- 13 Remove the coolant temperature sensor and its clamps.

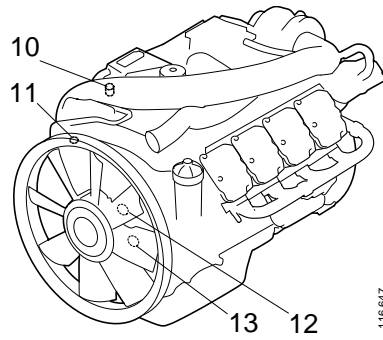

16 litre engine

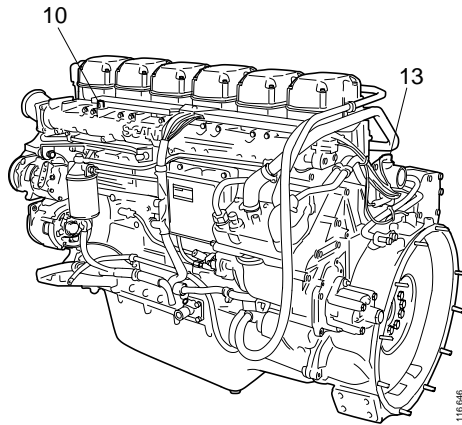

11 and 12 litre engines

Note: Handle the engine speed sensors with care. They are magnetic and sensitive to blows.

- 14 Remove the main engine speed sensor and its clamps.
- 15 Remove the auxiliary engine speed sensor and its clamps.

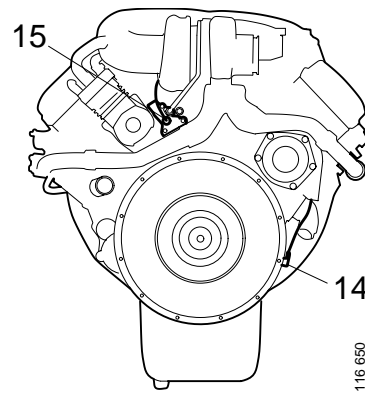

16 litre engine

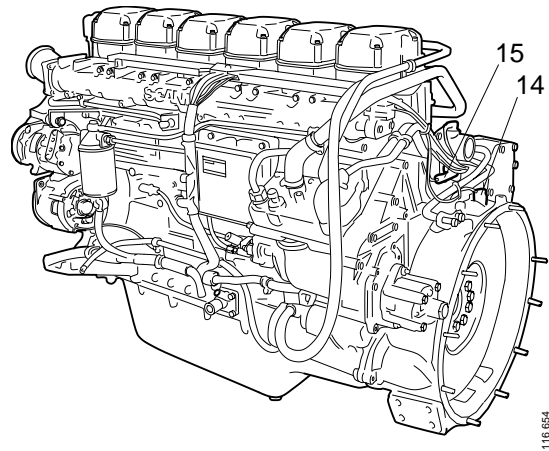

11 and 12 litre engines

cardiagn.com

Fitting the cables

Tightening torque

Unit injector solenoid valve screws

2.0 +/-0.2 Nm

18 ± 3Nm

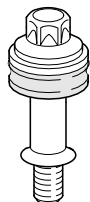

12 ± 3Nm

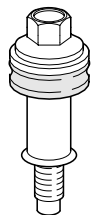

116 621

Bolts on the upper rocker covers.

Tools

Number

Description

Illustration

588 179

Torque screwdriver



Work description

- 1 16 litre engine: Make sure the inlet pipe between the turbocharger and the air cleaner has been removed.

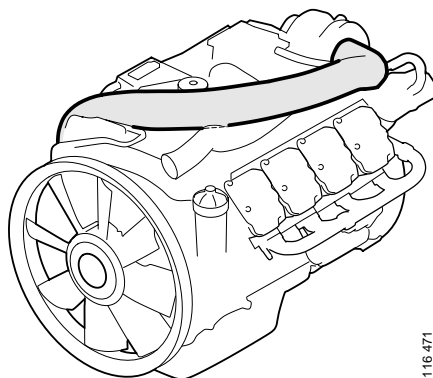

116 471

- 2 Fit the cable ducts. A schematic illustration of the location of the cable ducts and components is shown in the illustrations.

Cables and cable ducts on 11 and 12 litre engines

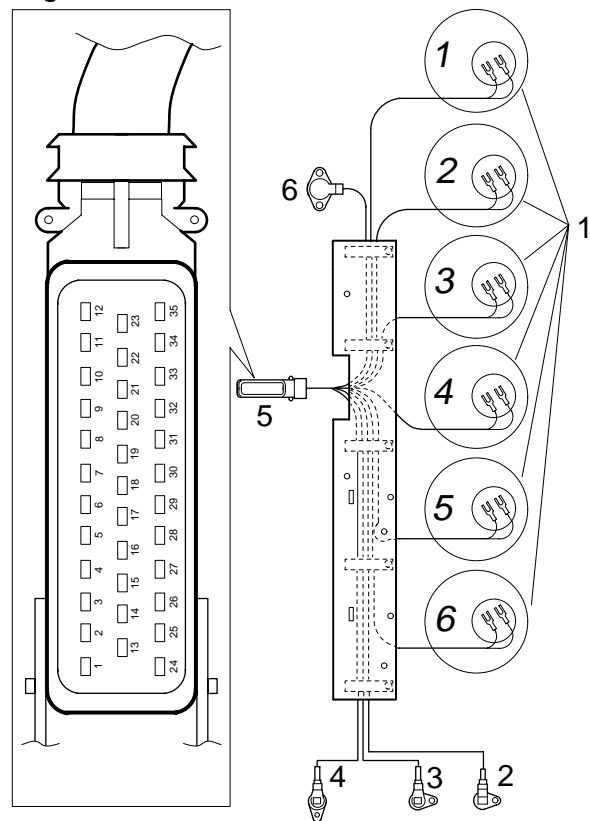

- 1 *Cylinders 1–6*
- 2 *Coolant temperature sensor*
- 3 *Main engine speed sensor on flywheel*
- 4 *Auxiliary engine speed sensor that monitors the camshaft gear*
- 5 *Connector to control unit*
- 6 *Charge air pressure and temperature sensor*

107 518

Cables and cable ducts on 16 litre engine

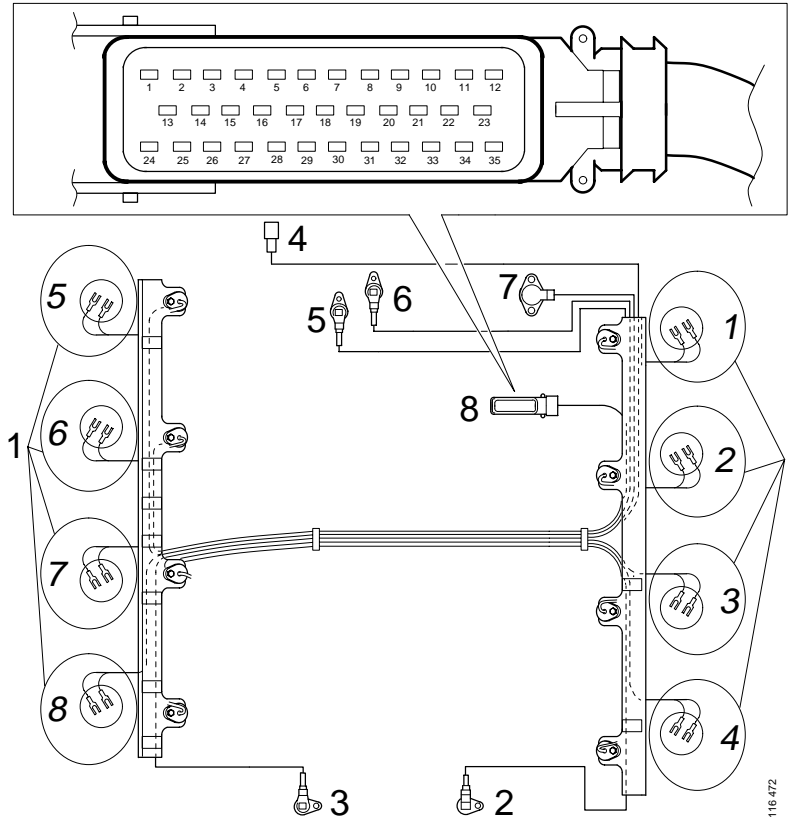

- 1 *Cylinders 1–8*
- 2 *Main engine speed sensor on flywheel*
- 3 *Auxiliary engine speed sensor that monitors the camshaft gear*
- 4 *Connector to fan solenoid valve*
- 5 *Coolant temperature sensor*
- 6 *Oil pressure sensor*
- 7 *Charge air pressure and temperature sensor*
- 8 *Connector to control unit*

- 3 Run the cables up to the unit injectors.

Make sure you have run the right cable up to the respective unit injector by testing with a multimeter as shown in the tables.

11 and 12 litre engines

Cylinder	Pin
1	28
2	27
3	26
4	33
5	35
6	34

16 litre engine

Cylinder	Pin
1	35
2	27
3	28
4	34
5	26
6	33
7	32
8	29

- 4 Press the cables into the groove in the lower rocker cover. See illustration.

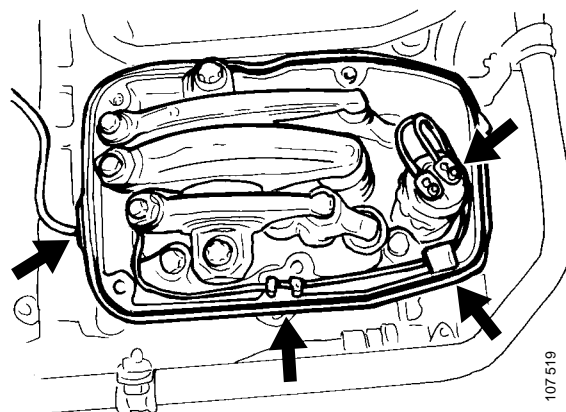

Note: Take care when tightening the cable connection screws on the unit injector. If the screws shear off, the unit injector must be replaced.

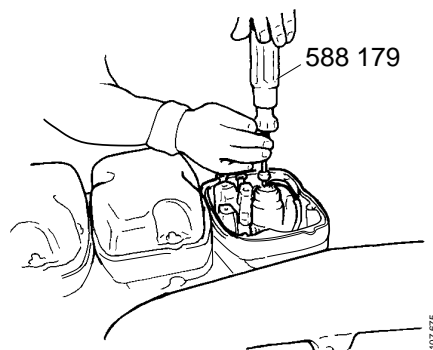

5 Fasten the cables to the unit injectors by tightening the screws. Use torque screwdriver 588 179 to tighten the screws to 2.0 +/-0.2 Nm.

6 16 litre engine: Screw on the grommets and cable ducts to the lower rocker covers.

11 and 12 litre engines: Screw on the grommets in the lower rocker covers.

7 16 litre engine: Fit the compressor air line. The air line is to be located on the left-hand cable duct.

- 8 16 litre engine: Fit the connector on the contact housing on the fan ring that is connected to the electrically controlled fan solenoid valve. Clamp the cable.
- 9 16 litre engine: Fit the oil pressure sensor and its clamps.
- 10 Fit the coolant temperature sensor and its clamps.
- 11 Fit the charge air sensor and its clamps.

11 and 12 litre engines: One of the charge air sensor screws is also used to fasten a cover.

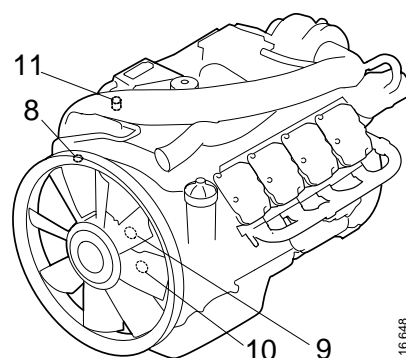

16 litre engine

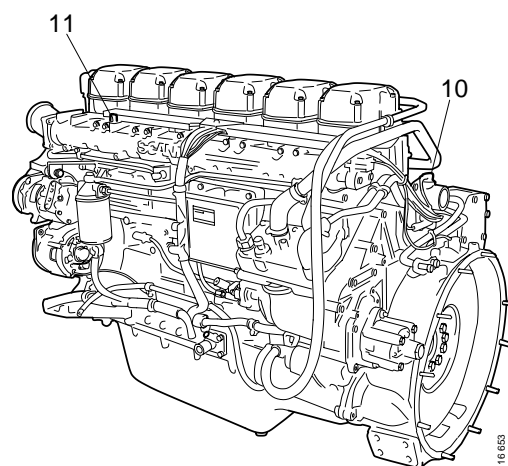

11 and 12 litre engines

Note: Handle the engine speed sensors with care. They are magnetic and sensitive to blows.

- 12 Fit the auxiliary engine speed sensor and its clamps.
- 13 Fit the main engine speed sensor and its clamps.
- 14 Plug in the two connectors on the control unit.
- 15 Connect Scania Diagnos to the vehicle and check the unit injectors by activating them. Check also that the values from the sensors are correct.

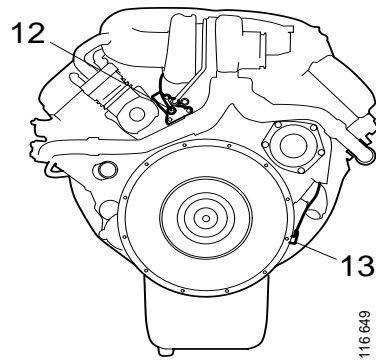

16 litre engine

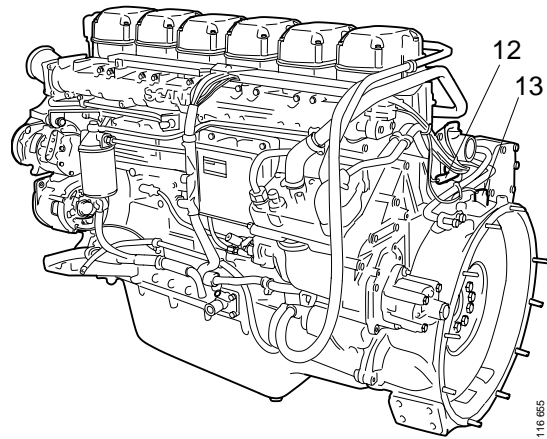

11 and 12 litre engines

- 16 Refit the upper rocker covers and torque tighten the bolts as illustrated.

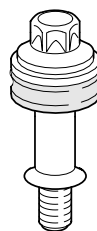
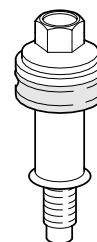
 $18 \pm 3\text{Nm}$  $12 \pm 3\text{Nm}$ 

116 621

- 17 11 and 12 litre engines: Connect the crankcase ventilation pipe to the upper rocker cover on cylinder 1 with a rubber spacer between the pipe and the rocker cover.
- 18 Fill with coolant as instructed in the work description for the coolant system.



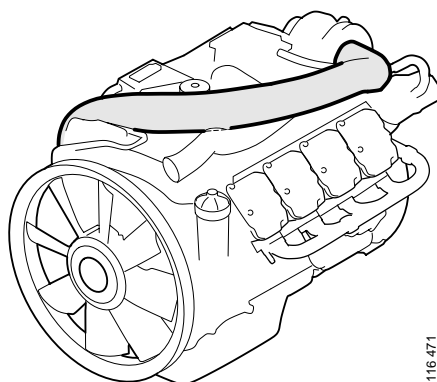

- 19 16 litre engine: Fit the inlet pipe between the turbocharger and the air cleaner.



116 471

Repairing the EDC cables

Tools

Number	Description	Illustration
588 200	Cable stripper	
588 207	Crimping tool	
588 220	Stripping tool	
587 602	Hot air gun	

If there is a fault on a component e.g. the coolant temperature sensor or an engine speed sensor, it has been necessary to renew the entire EDC cable harness on vehicles with EDC MS6. Stripping tool 588 220 should be used to avoid having to renew the entire cable harness.

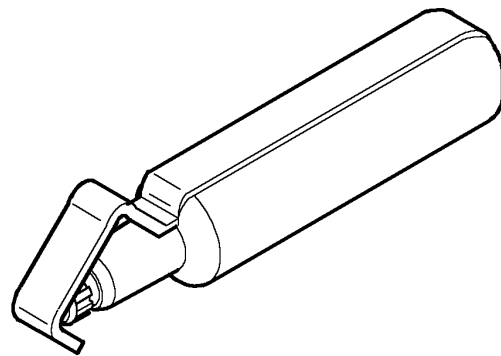

121449

Stripping tool 588 220.

- 1 Use Scania Diagnos to find the defective sensor.
- 2 All components have sufficient length on the cables so that the joints can be placed where the cables are straight and protected.
- 3 Splice on a new component. Place the joint where the cable is straight and protected. Use a multimeter and Scania Diagnos to make sure that there are no open circuits or short circuits in the cable harness.

Location of joints for components

11- and 12-litre engines

- The joints for **all** components should be placed under plate A.

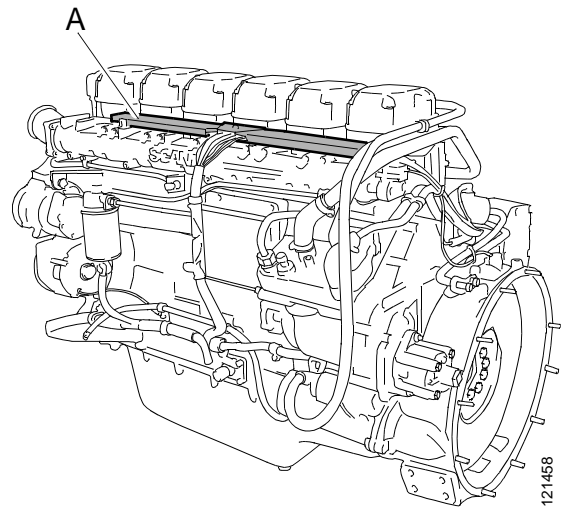

The joints for **all** components should be placed under plate A.

16-litre engine

- Joint the solenoid valve cables at A for cylinders 7 and 8.
- Joint the auxiliary engine speed sensor T75 and solenoid valve cables at B for cylinders 5 and 6.
- Joint the oil pressure sensor T5 and coolant temperature sensor T33 cables at C.
- Joint the main engine speed sensor T74, charge air pressure and temperature sensor T47 and solenoid valve cables at D for cylinders 1, 2, 3 and 4.

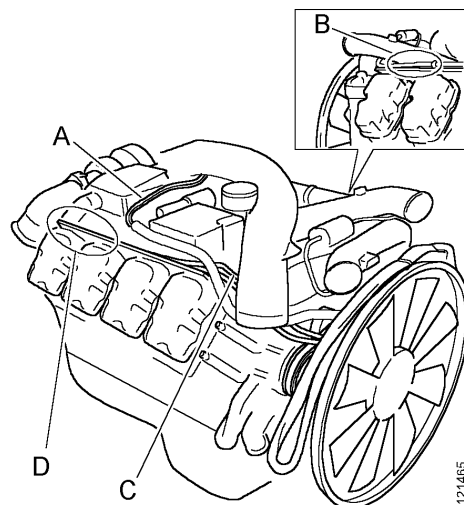

Note: The temperature sensor T47 and the solenoid valve cables for cylinders 1, 2 and 3 have very short cables. The new cable must be longer than the previous one to place the joint at D. The cable then bends in towards the control unit. See illustration.

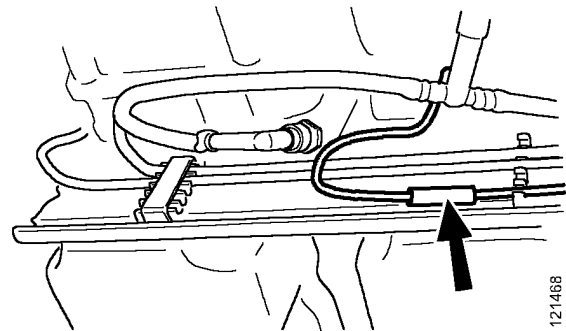

Joint on solenoid valve cable for cylinder 3.

Work description

- 1 Remove the defective component from the engine.
- 2 Release the cable and clean dirt and grease from it.
- 3 Mark on the cable where the centre point of the joint should be. It is preferable to place the joint between two cable retainers.
- 4 Cut the new cable as illustrated below. Add measurement B to the marked centre point.

Note: Remember to add measurement A to the marked centre point so that the cable from the control unit will not be too short.

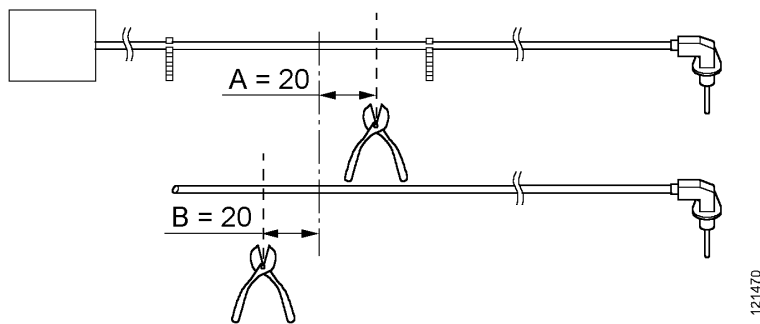

121470

2 wire cable

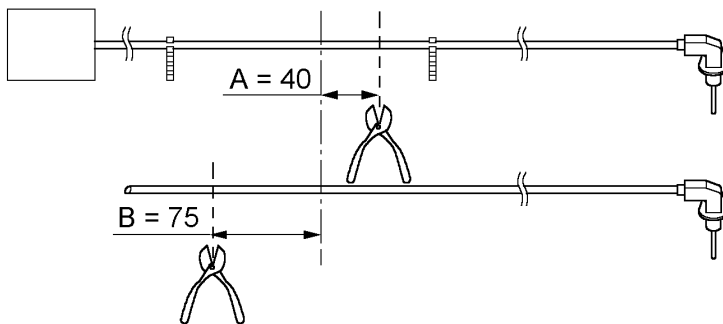

121471

4-wire cable.

The charge air pressure and temperature sensor and oil pressure sensor have 4 wire cables

- 5 Strip the cables using stripping tool 588 220. See illustration. Make sure that you do not damage the cable insulation.

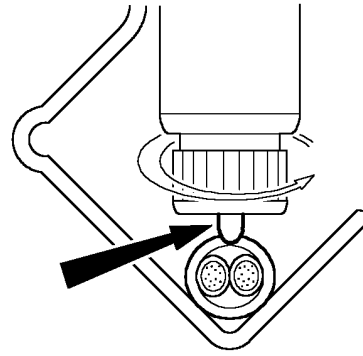

121473

- 6 Cut the cable as illustrated below. The centre line in the illustration is the mark on the cable
- 7 Locate the joints on the wires as illustrated below.
- 8 Strip off 7 mm of the insulation from the ends of the cables with cable stripper 588 200.

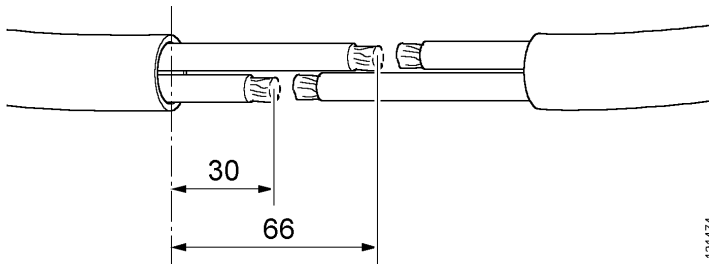

121474

2 wire cable

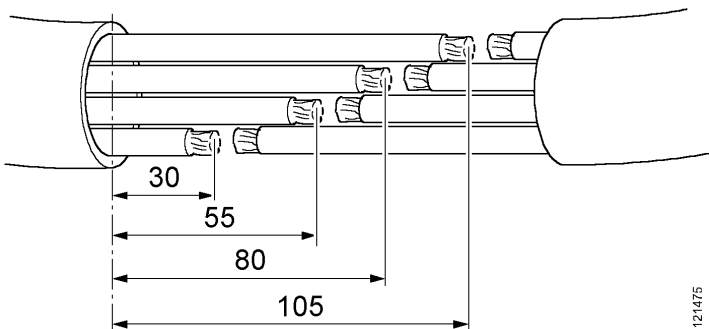

121475

4 wire cable

IMPORTANT! The joint must be sealed so that no moisture can penetrate.

- 9 Fit 40 mm long shrinking tubing Ø8 on each wire.
- 10 Fit shrinking tubing, Ø16, which is approximately 30 mm longer than the joint on the cable. Two shrinking tubings are used for 4-wire cable.
- 11 Clamp on the sleeves using crimping tool 588 207.
- 12 Heat the sleeves with a hot air gun e.g. 587 602 so that adhesive is forced out from the ends of the cables.

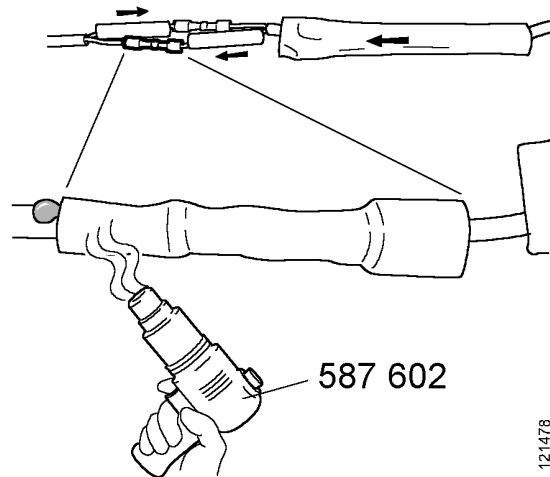

After the sleeves have been clamped on, the sleeves should be heated until adhesive is forced out.

- 13 Fit the wire shrinking tubing over the sleeves and heat it so that adhesive is forced out.
- 14 Fit the wire shrinking tubing over the entire joint and heat it so that adhesive is forced out.
- 15 Refit the cable. One of the rubber teeth in the cable retainer may have to be cut off if a new charge air pressure and temperature sensor T47 has been fitted.

EDC control unit

Renewing the control unit

Tightening torque

Control unit screws 22 Nm

Work description

IMPORTANT! The control unit can be damaged if it is still supplied with voltage while being unplugged. The ignition must therefore be turned off using the starter key and the EDC indicator lamp extinguished before the control unit is removed.

- 1 Unplug the two connectors from the control unit.
- 2 Remove the control unit retaining screws and then lift away the control unit.
- 3 Clean the contact surface on the control unit cooler.

Note: The threads in the cooler will be stripped if the control unit screws are tightened to a higher torque than 22 Nm.

- 4 Fit the new control unit into place and tighten the screws to 22 Nm.
- 5 Plug in the two connectors on the control unit.
- 6 Carry out the necessary programming with Scania Programmer.
- 7 Start the engine. Check and then erase fault codes with Scania Diagnos.

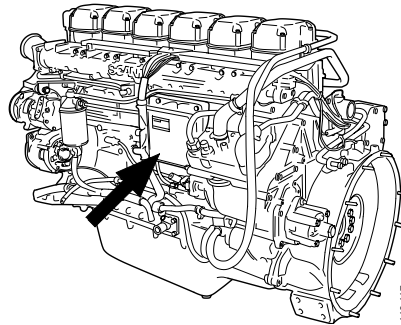

Location of EDC control unit on 11 and 12 litre engines

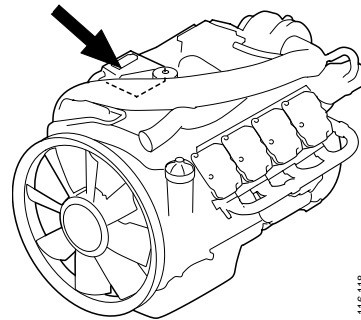

Location of EDC control unit on 16 litre engine.