

SCANIA

05:05-56

Issue 1 en

Comfort Shift, CS

Work description



54818

Contents

CS system components	4
Fault codes	5
Emergency gear changing	6
Electrical system	
Test programme	35
Control unit connections	41
Circuit diagram	43
Trouble shooting	
Gear control	47
Position sensors	48
Engine operating mode	48
Road speed sensor	48
Solenoid valves	49
Clutch pedal switches	49
Mechanical work	
Gear control	51
Solenoid valve	60
Checking wear	61
Checks and settings	61
Gear-changing pattern	63
Location of gearbox components	65
Specifications	67

CS system components

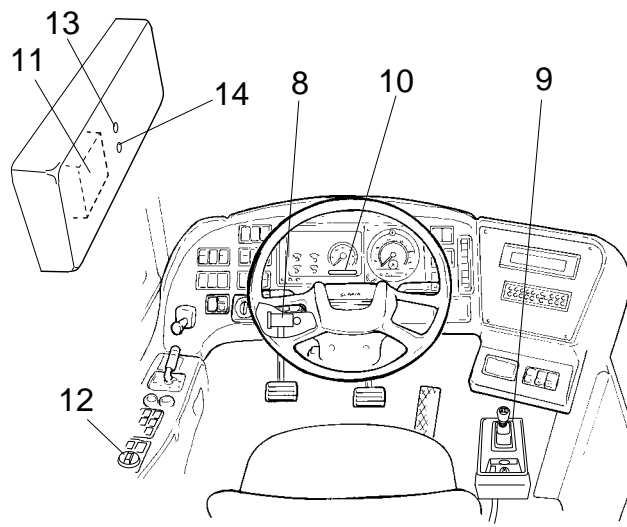
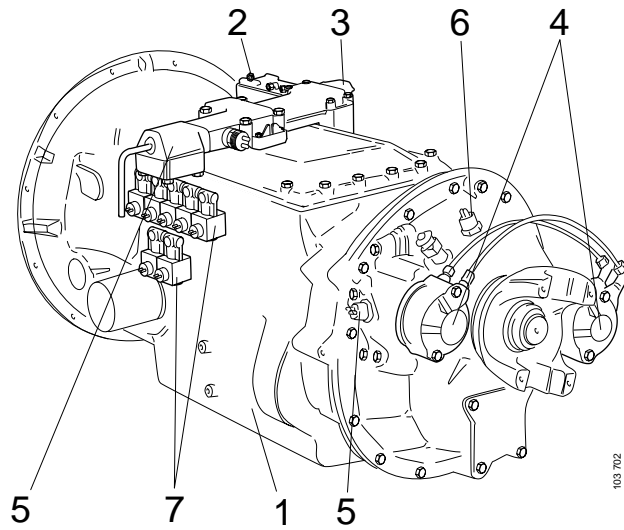

- | | | | |
|---|----------------------------------|----|---------------------------------------|
| 1 | Manual gearbox | 8 | Clutch pedal switches |
| 2 | Longitudinal stroke cylinder | 9 | Gear lever carrier |
| 3 | Lateral stroke cylinder | 10 | Gear indicator with buzzer |
| 4 | Control cylinders for range part | 11 | Control unit with code plug |
| 5 | Position sensors | 12 | Diagnostics switch for test programme |
| 6 | Speed sensing | 13 | Diagnostics socket |
| 7 | Solenoid valves | 14 | Delay relay |

Fault codes

Fault codes are generated in the control unit when disturbances in the operation of the CS system are detected.

Experience has shown that the cause is nearly always to be found in a component other than the control unit, such as a sensor, solenoid valve, the wiring or a connector. For this reason, first look for the cause of the fault in some other component before checking the control unit.

The list of fault codes contains a description of the conditions necessary for a fault code to be generated and suggested suitable remedial measures. The way in which the fault affects the control unit's gear-changing function is described in the comments.

When a fault code has been generated it may in certain circumstances affect the regular gear-changing or gear-selection function. If the control unit's power supply is switched off and on again, the function will be restored in spite of the fault code, provided that the fault does not recur.

There are three different categories of fault code:

A, B and C.

A: Generated when an electrical fault is detected in electrical components (including connectors and wiring).

B: May be generated as for A or if mechanical binding occurs. Try to determine primarily whether the code is generated because of mechanical binding or faulty adjustment.

C: May be generated as for A or if incorrect operation is detected. If no electrical fault has been detected, try to establish in conversation with the driver whether incorrect operation is the cause.

Category A faults can be rectified without further trouble shooting.

Category B and C faults require the cause to be checked more thoroughly.

Emergency gear changing

If the vehicle has been driven to a workshop with the emergency gear-changing function in operation, turn the knob back to position D before starting repair work.

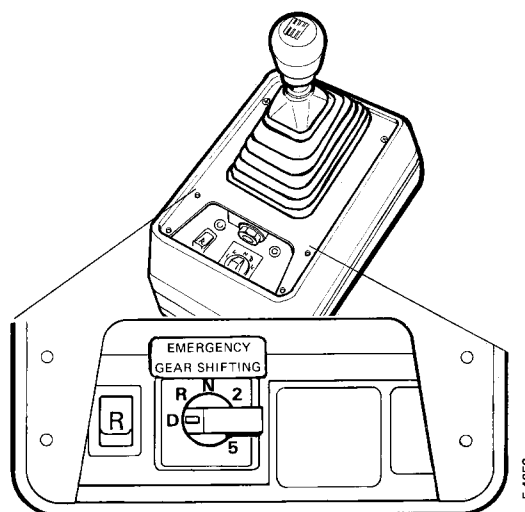

Fault code 01

Fault: Internal fault in the control unit.

Category A

Comment: The gear indicator may display "BLACKBOX".

Action: If the fault has occurred several times, change the control unit.

Fault code 03

Fault: No signal from the road speed sensor.

Category A

Cause: No road speed signal input on pins 16 and 34 of the control unit even though the following conditions are met:

- Clutch pedal released. The voltage on pins 2, 3 and 50 is lower than 9 V.
- Engine running. The voltage on pin 51 is higher than 10 V.
- A gear with a ratio higher than 8:1 is engaged. (Gears 2-7 on GR801.)

The fault code is generated after 5 seconds.

Comment: The buzzer sounds repeatedly. Only selection of a higher gear and neutral is permitted.

If the fault disappears, the control unit will return to normal operation.

The fault code may be generated if the fault concerns only one of the conditions, but in that case more fault codes ought to have been generated.

Action: Check the road speed sensor, connectors and wiring.

Check whether the clutch is slipping.

Check whether the engine is sending signals even when it is not running. This could be due to a fault in the alternator's diode bridge.

Circuit: 46, 53, 72, 75

Fault code 04

Category A

Fault: Defective contact in the code plug connector.

Cause: When power is turned on the control unit checks and approves the code plug. After this the code plug has been changed.

Comment: The driver receives no information when the fault occurs. Operation of the control unit is unaffected. The code plug that was valid when the control unit's power supply was turned on remains valid as long as the control unit continues to be supplied with power.

The fault may be caused by a bad contact or corrosion in the control unit's code plug connector.

Action: Unplug the code plug and plug it back in again. Check by means of the test programme whether the control unit senses the code plug's correct part number.

Note: If the fault is not rectified, it could in the worst case cause the control unit to use the wrong gear-changing sequences.

Fault code 06

Category A

Fault: Unidentified code plug.

Cause: The control unit can select neither gear-changing pattern nor engine type via the code plug.

The fault code is generated in the following cases:

1. Faulty code plug.
2. Fault in the control unit's code plug connector.
3. The control unit is of earlier design and not programmed for this code plug.

Comment: The gear indicator displays "CODEPLUG".

Action: Unplug the code plug and plug it back in again.

Case 1: Change the code plug.

Case 2: Change the control unit.

Case 3: Change the control unit.

Fault code 08**Category A**

Fault: No engine signal.

Cause: No input signal from the alternator. The signal indicates that the alternator is charging and that the engine is running.

The engine signal input on pin 51 is lower than 10 V, even though the following conditions are met:

- Clutch pedal released. The voltage on pins 2, 3 and 50 is lower than 9 V.
- A gear is engaged.
- Vehicle speed is above 50 km/h.

The fault code is generated after 10 seconds.

Comment: The buzzer sounds repeatedly.

Action: Check the alternator, connectors and wiring.

Circuit: 46, 53, 75

Note: After 5 gear changes the buzzer will stop.

Fault code 09**Category C**

Fault: Overrevving when changing gear.

Cause: Vehicle speed increase (acceleration) during gear-changing so that the selected gear causes the engine to over-rev. Gear-changing is interrupted.

Comment: Selection of a gear leading to high engine rpm, close to 3000 rpm, may cause a fault code to be generated.

Fault code 11

Category B

Fault: Gear-changing movement forward ordered but not confirmed.

Cause: Forward longitudinal stroke ordered from pin 41. No confirmation of this within 2 seconds, i.e. the input voltage on pin 45 is still lower than 10 V.

Comment: When gear-changing time exceeds 2.5 seconds, gear-changing is cancelled. The neutral and high-range solenoid valves are supplied with current for 0.5 seconds to return to the disengaged position. A fresh attempt to change gear can then be made with the clutch pedal depressed.

The fault code can also be generated if the gearbox seizes.

Fault code 61 can be generated for the same reason.

The fault code is not generated at speeds below 5 km/h.

Action: Check the control cylinders, the solenoid valve for forward stroke, compressed air lines, hall sensor with housing, connectors and wiring.

Circuit: 87, 105.

Fault code 12

Category B

Fault: Gear-changing movement rearward ordered but not confirmed.

Cause: Rearward longitudinal stroke ordered from pin 4. No confirmation of this within 2 seconds, i.e. the input voltage on pin 8 is still lower than 10 V.

Comment: When gear-changing time exceeds 2.5 seconds, gear-changing is cancelled. The neutral and high-range solenoid valves are supplied with current for 0.5 seconds to return to the disengaged position. A fresh attempt to change gear can then be made with the clutch pedal depressed.

The fault code can also be generated if the gearbox seizes.

Fault code 61 can be generated for the same reason.

The fault code is not generated at speeds below 5 km/h.

Action: Check the control cylinders, the solenoid valve for rearward stroke, compressed air lines, hall sensor with housing, connectors and wiring.

Circuit: 96, 112.

Fault code 13

Category B

Fault: Gear-changing movement right ordered but not confirmed.

Cause: Right lateral stroke ordered from pin 5. No confirmation of this within 0.5 seconds, i.e. the input voltage on pin 9 is still lower than 10 V.

Comment: When gear-changing time exceeds 2.5 seconds, gear-changing is cancelled. The neutral and high-range solenoid valves are supplied with current for 0.5 seconds. A fresh attempt to change gear can then be made with the clutch pedal depressed.

The fault code can also be generated if the gearbox seizes.

Fault code 53 can be generated for the same reason.

Action: Check the control cylinders, the solenoid valve for right lateral stroke, compressed air lines, hall sensor with housing, connectors and wiring.

Circuit: 95, 110.

Fault code 14

Category B

Fault: Gear-changing movement left ordered but not confirmed.

Cause: Left lateral stroke ordered from pin 23. No confirmation of this within 0.5 seconds, i.e. the input voltage on pin 27 is still lower than 10 V.

Comment: When gear-changing time exceeds 2.5 seconds, gear-changing is cancelled. The neutral and high-range solenoid valves are supplied with current for 0.5 seconds. A fresh attempt to change gear can then be made with the clutch pedal depressed.

The fault code can also be generated if the gearbox seizes.

Fault code 52 can be generated for the same reason.

Action: Check the control cylinders, the solenoid valve for left lateral stroke, compressed air lines, hall sensor with housing, connectors and wiring.

Circuit: 93, 103.

Fault code 15

Category B

Fault: Gear-changing movement from high to low range ordered but not confirmed.

Cause: Low range ordered from pin 24. No confirmation of this within 2 seconds, i.e. the input voltage on pin 29 is still lower than 10 V.

Comment: When gear-changing time exceeds 2.5 seconds, gear-changing is cancelled. The neutral and high-range solenoid valves are supplied with current for 0.5 seconds to return to the disengaged position. A fresh attempt to change gear can then be made with the clutch pedal depressed.

The fault code can also be generated if the gearbox seizes.

Fault code 58 can be generated for the same reason.

The fault code is not generated at speeds below 5 km/h.

Action: Check the control cylinders, the solenoid valve for low range, compressed air lines, hall sensor with housing, connectors and wiring.

Circuit: 84, 114.

Fault code 16

Category B

Fault: Gear-changing movement from low to high range ordered but not confirmed.

Cause: High range ordered from pin 6. No confirmation of this within 2 seconds, i.e. the input voltage on pin 28 is still lower than 10 V.

Comment: When gear-changing time exceeds 2.5 seconds, gear-changing is cancelled. The neutral and high-range solenoid valves are supplied with current for 0.5 seconds to return to the disengaged position. A fresh attempt to change gear can then be made with the clutch pedal depressed.

The fault code can also be generated if the gearbox seizes.

Fault code 57 can be generated for the same reason.

The fault code is not generated at speeds below 5 km/h.

Action: Check the control cylinders, the solenoid valve for high range, compressed air lines, hall sensor with housing, connectors and wiring.

Circuit: 81, 116.

Fault code 19

Category B

Fault: Gear-changing movement neutral ordered but not confirmed.

Cause: Neutral ordered from pin 42. No confirmation of this within 1 second, i.e. the input voltage on pin 46 is still lower than 10 V.

Comment: When gear-changing time exceeds 2.5 seconds, gear-changing is cancelled. The neutral and high-range solenoid valves are supplied with current for 0.5 seconds. A fresh attempt to change gear can then be made with the clutch pedal depressed.

The fault code can also be generated if the gearbox seizes.

Fault codes 55 and 56 can be generated for the same reason.

The fault code is not generated at speeds below 5 km/h.

Action: Check the control cylinders, the solenoid valve for neutral, compressed air lines, hall sensor with housing, connectors and wiring.

Circuit: 89, 107.

Fault code 20

Category A

Fault: Break or short-circuit in the leads to the solenoid valve for forward longitudinal stroke.

Cause: Power consumption too low or too high from control unit pin 41.

Comment: When the solenoid valve for forward longitudinal stroke is activated, the control unit can sense the following cases. Break: circuit not consuming any current. Short-circuit: current in circuit too high.

For the fault code to be generated afresh, power consumption must undergo a sudden change as might be caused by a loose contact. In the case of a persistent fault, the fault code will be generated afresh the first time the control unit attempts to activate the solenoid valve after the power has been switched on.

A high current could be caused by shorted windings in the solenoid valve coil, for instance.

Gear-changing is cancelled. A fresh attempt to change gear can then be made after 2.5 seconds with the clutch pedal depressed.

Action: Check the solenoid valve for forward longitudinal stroke, the connectors and wiring.

Circuit: 105.

Fault code 21

Category A

Fault: Break or short-circuit in the leads to the solenoid valve for rearward longitudinal stroke.

Cause: Power consumption too low or too high from control unit pin 4.

Comment: When the solenoid valve for rearward longitudinal stroke is activated, the control unit can sense the following cases. Break: circuit not consuming any current. Short-circuit: current in circuit too high.

For the fault code to be generated afresh, power consumption must undergo a sudden change as might be caused by a loose contact. In the case of a persistent fault, the fault code will be generated afresh the first time the control unit attempts to activate the solenoid valve after the power has been switched on.

A high current could be caused by shorted windings in the solenoid valve coil, for instance.

Gear-changing is cancelled. A fresh attempt to change gear can then be made after 2.5 seconds with the clutch pedal depressed.

Action: Check the solenoid valve for forward longitudinal stroke, the connectors and wiring.

Circuit: 112.

Fault code 22

Category A

Fault: Break or short-circuit in the leads to the solenoid valve for right-hand lateral stroke.

Cause: Power consumption too low or too high from control unit pin 5.

Comment: When the solenoid valve for right-hand lateral stroke is activated, the control unit can sense the following cases. Break: circuit not consuming any current. Short-circuit: current in circuit too high.

For the fault code to be generated afresh, power consumption must undergo a sudden change as might be caused by a loose contact. In the case of a persistent fault, the fault code will be generated afresh the first time the control unit attempts to activate the solenoid valve after the power has been switched on.

A high current could be caused by shorted windings in the solenoid valve coil, for instance.

Gear-changing is cancelled. A fresh attempt to change gear can then be made after 2.5 seconds with the clutch pedal depressed.

Action: Check the solenoid valve for right-hand lateral stroke, the connectors and wiring.

Circuit: 110.

Fault code 23

Category A

Fault: Break or short-circuit in the leads to the solenoid valve for left-hand lateral stroke.

Cause: Power consumption too low or too high from control unit pin 23.

Comment: When the solenoid valve for left-hand lateral stroke is activated, the control unit can sense the following cases. Break: circuit not consuming any current. Short-circuit: current in circuit too high.

For the fault code to be generated afresh, power consumption must undergo a sudden change as might be caused by a loose contact. In the case of a persistent fault, the fault code will be generated afresh the first time the control unit attempts to activate the solenoid valve after the power has been switched on.

A high current could be caused by shorted windings in the solenoid valve coil, for instance.

Gear-changing is cancelled. A fresh attempt to change gear can then be made after 2.5 seconds with the clutch pedal depressed.

Action: Check the solenoid valve for left-hand lateral stroke, the connectors and wiring.

Circuit: 103.

Fault code 24

Category A

Fault: Break or short-circuit in the leads to the solenoid valve for low range.

Cause: Power consumption too low or too high from control unit pin 24.

Comment: When the solenoid valve for low range is activated, the control unit can sense the following cases. Break: circuit not consuming any current. Short-circuit: current in circuit too high.

For the fault code to be generated afresh, power consumption must undergo a sudden change as might be caused by a loose contact. In the case of a persistent fault, the fault code will be generated afresh the first time the control unit attempts to activate the solenoid valve after the power has been switched on.

A high current could be caused by shorted windings in the solenoid valve coil, for instance.

Gear-changing is cancelled. A fresh attempt to change gear can then be made after 2.5 seconds with the clutch pedal depressed.

Action: Check the solenoid valve for low range, the connectors and wiring.

Circuit: 114.

Fault code 25

Category A

Fault: Break or short-circuit in the leads to the solenoid valve for high range.

Cause: Power consumption too low or too high from control unit pin 6.

Comment: When the solenoid valve for high range is activated, the control unit can sense the following cases. Break: circuit not consuming any current. Short-circuit: current in circuit too high.

For the fault code to be generated afresh, power consumption must undergo a sudden change as might be caused by a loose contact. In the case of a persistent fault, the fault code will be generated afresh the first time the control unit attempts to activate the solenoid valve after the power has been switched on.

A high current could be caused by shorted windings in the solenoid valve coil, for instance.

Gear-changing is cancelled. A fresh attempt to change gear can then be made after 2.5 seconds with the clutch pedal depressed.

Action: Check the solenoid valve for high range, the connectors and wiring.

Circuit: 117.

Fault code 28

Category A

Fault: Break or short-circuit in the leads to the solenoid valve for neutral position.

Cause: Power consumption too low or too high from control unit pin 42.

Comment: When the solenoid valve for neutral position is activated, the control unit can sense the following cases. Break: circuit not consuming any current. Short-circuit: current in circuit too high.

For the fault code to be generated afresh, power consumption must undergo a sudden change as might be caused by a loose contact. In the case of a persistent fault, the fault code will be generated afresh the first time the control unit attempts to activate the solenoid valve after the power has been switched on.

A high current could be caused by shorted windings in the solenoid valve coil, for instance.

Gear-changing is cancelled. A fresh attempt to change gear can then be made after 2.5 seconds with the clutch pedal depressed.

Action: Check the solenoid valve for neutral position, the connectors and wiring.

Circuit: 107.

Fault code 29

Category A

Fault: Break or short-circuit in the leads to the solenoid valve for gear-changing confirmation.

Cause: Power consumption too low or too high from control unit pin 21.

Comment: When the solenoid valve for gear-changing confirmation is activated, the control unit can sense the following cases. Break: circuit not consuming any current. Short-circuit: current in circuit too high.

For the fault code to be generated afresh, power consumption must undergo a sudden change as might be caused by a loose contact. In the case of a persistent fault, the fault code will be generated afresh the first time the control unit attempts to activate the solenoid valve after the power has been switched on.

A high current could be caused by shorted windings in the solenoid valve coil, for instance.

If the solenoid valve is faulty, no gear-changing confirmation will be obtained in the CS lever.

Action: Check the solenoid valve for gear-changing confirmation, the connectors and wiring.

Circuit: 29.

Fault code 30

Category A

Fault: The safety relay in the control unit is defective.

Cause: The first time the clutch pedal is depressed after power is switched on, the control unit checks its safety relay by attempting to activate the driver stage for the neutral position solenoid valve. If this is successful, the fault code may have been generated as a result of the following:

- 1 One of the 7 driver stages for the solenoid valves has been supplied with current through a short-circuit to +24 V, such as may have occurred in the wiring.
- 2 The safety relay is defective.

Comment: The buzzer sounds repeatedly and no gear-changing is allowed.

Action: Case 1. Check that no solenoid valve is activated when the clutch pedal is released.

Case 2. Change the control unit.

Circuit: 103-116.

Fault code 33

Category C

Fault: Continuous signal from the upper clutch pedal switch.

Cause: The input power on pin 50 has been higher than 10 V for 10 minutes. At the same time, the input power on pins 2 and 3 has been lower than 10 V.

Comment: The clutch pedal switch cannot normally remain closed for such a long time unless the driver rests his foot on the clutch pedal while driving.

When the switch is activated, it activates a relay which supplies pin 50 with system voltage (24 V).

The buzzer sounds repeatedly. Only selection of a higher gear or neutral is allowed.

Action: Check the upper clutch pedal switch, relay R515, the connectors and wiring.

Circuit: 46-53.

Fault code 34

Category A

Fault: Implausible signals from the clutch pedal switches.

Cause: The input power on pins 2 and 3 has been higher than 10 V. At the same time, the input power on pin 50 has been lower than 9 V.

Comment: The lower clutch pedal switch has been closed although the upper clutch pedal switch was not closed. This should not be possible during normal driving.

When the lower switch is activated, it closes and supplies pins 2 and 3 with +24 V.

When the upper switch is activated, it activates a relay which supplies pin 50 with system voltage (24 V).

No gear-changing is allowed.

Action: Check the clutch pedal switches, relay R515, the connectors and wiring.

Circuit: 46-53.

Fault code 35

Category C

Fault: Continuous signal from the diagnostics switch.

Cause: The input power on pin 44 has been lower than 9 V for 60 seconds.

Comment: The diagnostics switch cannot remain depressed for such a long time during normal driving. Activating this switch connects it to system earth (0 V).

If this fault occurs as soon as the driver turns on the power, all fault codes will be erased and the gear indicator will display "ERASE".

The test programme cannot be started and the test lamp comes on.

Action: Check the diagnostics switch, the connectors and wiring.

Circuit: 146.

Fault code 37

Category B

Fault: Loss of confirmation signal for forward stroke.

Cause: The control unit has sensed that the voltage level of the confirmation signal on pin 45 has suddenly changed.

Comment: For the control unit to check for loss of the confirmation signal, a complete gear-changing sequence must first be performed. When the clutch pedal has subsequently been released for more than 5 seconds, the control unit can check that the confirmation signal has not changed. The fault code could be generated if the gear "jumps out" due to a mechanical fault, for instance.

If the gear indicator shows "--" it is because the control unit does not recognize the combination of signals.

Action: Check the hall effect sensor, connectors and wiring.

Circuit: 87.

Fault code 38**Category B**

Fault: Loss of confirmation signal for rearward stroke.

Cause: The control unit has sensed that the voltage level of the confirmation signal on pin 8 has suddenly changed.

Comment: For the control unit to check for loss of the confirmation signal, a complete gear-changing sequence must first be performed. When the clutch pedal has subsequently been released for more than 5 seconds, the control unit can check that the confirmation signal has not changed. The fault code could be generated if the gear "jumps out" due to a mechanical fault, for instance.

If the gear indicator shows "--" it is because the control unit does not recognize the combination of signals.

Action: Check the hall effect sensor, connectors and wiring.

Circuit: 96.

Fault code 39**Category B**

Fault: Loss of confirmation signal for right lateral stroke.

Cause: The control unit has sensed that the voltage level of the confirmation signal on pin 9 has suddenly changed.

Comment: For the control unit to check for loss of the confirmation signal, a complete gear-changing sequence must first be performed. When the clutch pedal has subsequently been released for more than 5 seconds, the control unit can check that the confirmation signal has not changed. The fault code could be generated if the gear "jumps out" due to a mechanical fault, for instance.

If the gear indicator shows "--" it is because the control unit does not recognize the combination of signals.

Action: Check the hall effect sensor, connectors and wiring.

Circuit: 95.

Fault code 40

Category B

Fault: Loss of confirmation signal for left lateral stroke.

Cause: The control unit has sensed that the voltage level of the confirmation signal on pin 27 has suddenly changed.

Comment: For the control unit to check for loss of the confirmation signal, a complete gear-changing sequence must first be performed. When the clutch pedal has subsequently been released for more than 5 seconds, the control unit can check that the confirmation signal has not changed. The fault code could be generated if the gear "jumps out" due to a mechanical fault, for instance.

If the gear indicator shows "--" it is because the control unit does not recognize the combination of signals.

Action: Check the hall effect sensor, connectors and wiring.

Circuit: 93.

Fault code 41

Category B

Fault: Loss of confirmation signal for low range.

Cause: The control unit has sensed that the voltage level of the confirmation signal on pin 29 has suddenly changed.

Comment: For the control unit to check for loss of the confirmation signal, a complete gear-changing sequence must first be performed. When the clutch pedal has subsequently been released for more than 5 seconds, the control unit can check that the confirmation signal has not changed. The fault code could be generated if the gear "jumps out" due to a mechanical fault, for instance.

If the gear indicator shows "--" it is because the control unit does not recognize the combination of signals.

Action: Check the hall effect sensor, connectors and wiring.

Circuit: 83.

Fault code 42

Category B

Fault: Loss of confirmation signal for high range.

Cause: The control unit has sensed that the voltage level of the confirmation signal on pin 28 has suddenly changed.

Comment: For the control unit to check for loss of the confirmation signal, a complete gear-changing sequence must first be performed. When the clutch pedal has subsequently been released for more than 5 seconds, the control unit can check that the confirmation signal has not changed. The fault code could be generated if the gear "jumps out" due to a mechanical fault, for instance.

If the gear indicator shows "--" it is because the control unit does not recognize the combination of signals.

Action: Check the hall effect sensor, connectors and wiring.

Circuit: 81.

Fault code 45

Category B

Fault: Loss of confirmation signal for neutral position.

Cause: The control unit has sensed that the voltage level of the confirmation signal on pin 46 has suddenly changed.

Comment: For the control unit to check for loss of the confirmation signal, a complete gear-changing sequence must first be performed. When the clutch pedal has subsequently been released for more than 5 seconds, the control unit can check that the confirmation signal has not changed. The fault code could be generated if the gear "jumps out" due to a mechanical fault, for instance.

If the gear indicator shows "--" it is because the control unit does not recognize the combination of signals.

Action: Check the hall effect sensor, connectors and wiring.

Circuit: 88.

Fault code 46

Category A

Fault: Erroneous activation of the solenoid valve for low range.

Cause: Power has been supplied to control unit pin 24 without gear-changing having been ordered.

Comment: The fault code is generated if the control unit's pin has been supplied with power erroneously, such as shorting to +24 V.

The fault code can also be generated by an internal control unit fault.

The buzzer sounds repeatedly and no gear-changing is allowed.

Action: Disconnect the lead from pin 24 and take a reading with a multimeter. Check the connectors and wiring.

Change the control unit.

Circuit: 114.

Fault code 47**Category A**

Fault: Erroneous activation of the solenoid valve for forward stroke.

Cause: Power has been supplied to control unit pin 41 without gear-changing having been ordered.

Comment: The fault code is generated if the control unit's pin has been supplied with power erroneously, such as shorting to +24 V.

The fault code can also be generated by an internal control unit fault.

The buzzer sounds repeatedly and no gear-changing is allowed.

Action: Disconnect the lead from pin 41 and take a reading with a multimeter. Check the connectors and wiring.

Change the control unit.

Circuit: 105.

Fault code 48**Category A**

Fault: Erroneous activation of the solenoid valve for rearward stroke.

Cause: Power has been supplied to control unit pin 4 without gear-changing having been ordered.

Comment: The fault code is generated if the control unit's pin has been supplied with power erroneously, such as shorting to +24 V.

The fault code can also be generated by an internal control unit fault.

The buzzer sounds repeatedly and no gear-changing is allowed.

Action: Disconnect the lead from pin 4 and take a reading with a multimeter. Check the connectors and wiring.

Change the control unit.

Circuit: 112.

Fault code 50

Category C

Fault: Gear-changing cancelled.

Cause: Gear-changing cancelled because the clutch pedal was released too soon.

Comment: The driver released the clutch pedal before gear-changing was completed. The fault code is generated after 10 cancelled gear changes. The driver will notice the fault because neutral is often obtained instead of the gear selected.

The fault code can also be generated by a loose contact on the lower clutch pedal switch.

Fault code 52

Category B

Fault: Continuous confirmation signal for right lateral stroke.

Cause: Power (over 9 V) has remained on pin 9 for longer than 1 second after pin 46 has been supplied with power (over 10 V).

Comment: The confirmation signal must not be applied for longer than 1 second after neutral position confirmation in connection with right lateral stroke.

When gear-changing time exceeds 2.5 seconds, gear-changing is cancelled. The neutral and high-range solenoid valves are supplied with current for 0.5 seconds. A fresh attempt to change gear can then be made with the clutch pedal depressed.

The fault code can also be generated if the gearbox seizes.

Fault code 14 can be generated for the same reason.

Action: Check the control cylinders, the solenoid valve for right lateral stroke, the compressed air lines, hall sensor, connectors and wiring.

Circuit: 88, 95.

Fault code 53**Category B**

Fault: Continuous confirmation signal for left lateral stroke.

Cause: Power (over 9 V) has remained on pin 27 for longer than 1 second after pin 46 has been supplied with power (over 10 V).

Comment: The confirmation signal must not be applied for longer than 1 second after neutral position confirmation in connection with left lateral stroke.

When gear-changing time exceeds 2.5 seconds, gear-changing is cancelled. The neutral and high-range solenoid valves are supplied with current for 0.5 seconds. A fresh attempt to change gear can then be made with the clutch pedal depressed.

The fault code can also be generated if the gearbox seizes.

Fault code 13 can be generated for the same reason.

Action: Check the control cylinders, the solenoid valve for left lateral stroke, the compressed air lines, hall sensor, connectors and wiring.

Circuit: 88, 93.

Fault code 54**Category A**

Fault: Loss of signal from road speed sensor.

Cause: The control unit has in two consecutive measurement periods detected on pins 16 and 34 a speed higher than 10 km/h and a speed of 0 km/h.

Comment: The buzzer sounds repeatedly. Only selection of a higher gear and neutral is permitted.

If the fault disappears, the control unit will return to normal operation.

Action: Check the road speed sensor, connectors and wiring.

Circuit: 71-72.

Fault code 55

Category B

Fault: Continuous confirmation signal for forward longitudinal stroke.

Cause: Power (over 9 V) has remained on pin 45 for longer than 1 second after pin 42 has supplied the solenoid valve with power.

Comment: The confirmation signal must not be applied for longer than 1 second after activation of the solenoid valve for forward longitudinal stroke.

When gear-changing time exceeds 2.5 seconds, gear-changing is cancelled. The neutral and high-range solenoid valves are supplied with current for 0.5 seconds. A fresh attempt to change gear can then be made with the clutch pedal depressed.

The fault code can also be generated if the gearbox seizes.

Fault code 19 can be generated for the same reason.

The fault code is not generated at speeds below 5 km/h.

Action: Check the control cylinders, the solenoid valve for neutral position, the compressed air lines, hall sensor, connectors and wiring.

Circuit: 87, 107.

Fault code 56

Category B

Fault: Continuous confirmation signal for rearward longitudinal stroke.

Cause: Power (over 9 V) has remained on pin 8 for longer than 1 second after pin 42 has supplied the solenoid valve with power.

Comment: The confirmation signal must not be applied for longer than 1 second after activation of the solenoid valve for rearward longitudinal stroke.

When gear-changing time exceeds 2.5 seconds, gear-changing is cancelled. The neutral and high-range solenoid valves are supplied with current for 0.5 seconds. A fresh attempt to change gear can then be made with the clutch pedal depressed.

The fault code can also be generated if the gearbox seizes.

Fault code 19 can be generated for the same reason.

The fault code is not generated at speeds below 5 km/h.

Action: Check the control cylinders, the solenoid valve for neutral position, the compressed air lines, hall sensor, connectors and wiring.

Circuit: 96, 107.

Fault code 57

Category B

Fault: Continuous confirmation signal for low range.

Cause: Power (over 9 V) has remained on pin 29 for longer than 2 seconds after pin 6 has supplied the solenoid valve with power.

Comment: The confirmation signal for low range must not be applied for longer than 2 seconds after high range has been ordered. When gear-changing time exceeds 2.5 seconds, gear-changing is cancelled. The neutral and high-range solenoid valves are supplied with current for 0.5 seconds. A fresh attempt to change gear can then be made with the clutch pedal depressed.

The fault code can also be generated if the gearbox seizes.

Fault code 16 can be generated for the same reason.

The fault code is not generated at speeds below 5 km/h.

Action: Check the control cylinders, the solenoid valve for high range, the compressed air lines, hall sensor, connectors and wiring.

Circuit: 84, 116.

Fault code 58

Category B

Fault: Continuous confirmation signal for high range.

Cause: Power (over 9 V) has remained on pin 28 for longer than 2 seconds after pin 24 has supplied the solenoid valve with power.

Comment: The confirmation signal for high range must not be applied for longer than 2 seconds after low range has been ordered. When gear-changing time exceeds 2.5 seconds, gear-changing is cancelled. The neutral and high-range solenoid valves are supplied with current for 0.5 seconds. A fresh attempt to change gear can then be made with the clutch pedal depressed.

The fault code can also be generated if the gearbox seizes.

Fault code 15 can be generated for the same reason.

The fault code is not generated at speeds below 5 km/h.

Action: Check the control cylinders, the solenoid valve for high range, the compressed air lines, hall sensor, connectors and wiring.

Circuit: 81, 114.

Fault code 61**Category B**

Fault: Continuous confirmation signal for neutral position.

Cause: Power (over 9 V) has remained on pin 46 for longer than 2 seconds after pin 41 or pin 4 has supplied the relevant solenoid valve with power.

Comment: The confirmation signal for neutral position must not be applied for longer than 2 seconds after the solenoid valve for forward or rearward stroke is activated from neutral. When gear-changing time exceeds 2.5 seconds, gear-changing is cancelled. The neutral and high-range solenoid valves are supplied with current for 0.5 seconds. A fresh attempt to change gear can then be made with the clutch pedal depressed.

The fault code can also be generated if the gearbox seizes.

Fault codes 11 and 12 can be generated for the same reason.

The fault code is not generated at speeds below 5 km/h.

Action: Check the control cylinders, the solenoid valves for forward and rearward stroke, the compressed air lines, hall sensor, connectors and wiring.

Circuit: 88, 105, 112.

Fault code 63

Category B

Fault: Implausible signals from the CS lever longitudinally.

Cause: The control unit senses the ordering of several gears at the same time.

Comment: The fault code is generated in the following cases:

- the voltage on pin 12 is higher than 10 V at the same time as the voltage on pins 31 and 13 is lower than 9 V.
- the voltage on pin 31 is higher than 10 V at the same time as the voltage on pin 13 is higher than 10 V.

The fault code is generated after 2 seconds. No gear is engaged.

Action: Check the CS lever, the connectors and wiring.

Fault code 64

Category B

Fault: Implausible signals from the CS lever laterally.

Cause: The control unit senses the ordering of several gears at the same time.

Comment: The fault code is generated in the following case:

- the voltage on pin 31 or pin 13 is higher than 10 V at the same time as the voltage on pins 30, 11, 36 and 49 is lower than 9 V.

The fault code is generated after 2 seconds. No gear is engaged.

Action: Check the CS lever, the connectors and wiring.

Electrical system

Test programme

The CS system is equipped with a test programme with which circuits and gear-changing movements can be checked and any faults can quickly be traced.

The test programme consists of four stages. Each stage is reached by pressing the diagnostics switch for about 1/2 second and then releasing it. The gearbox should be in neutral. The vehicle must be stationary so that the test programme will not be interrupted.

Test all stages one by one, even if only one system is to be checked. When the switch has been pressed for the fifth time the programme will end.

The test programme can also be stopped by turning off the power with the starter key.

Preparation

Proceed as follows before starting the test programme:

- 1 Change up and down using all the gears, including reverse. Note whether any gear cannot be engaged.
- 2 Listen for acoustic signals, see below.

Note: The warning for engaged gear and engine switched off is removed after 5 gear changes.

Signals from the buzzer

Buzzer signals warn the driver of operating faults or faults arising in the CS system.

2 signals / second

Warns the driver against leaving the vehicle with a gear engaged and the engine switched off. Since the clutch is operated by means of compressed air it will be heavy going if the vehicle is left in this state long enough for the compressed air system to lose all pressure. The signal continues for about 10 seconds.

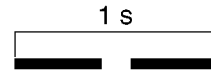

108 271

3 signals / second

Warns that the speedometer is unreliable.

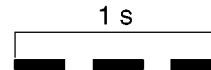

108 272

10 signals / second

Advises that overrevving protection has been engaged.

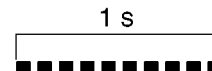

108 273

Starting the test program

Switch on the power using the starter key.

First depression

- All the gear indicator character positions light up one by one for 1 second and go out for 1 second and the buzzer sounds for 2 seconds.
- The code plug part number is displayed for 2 seconds.
- The part number of the control unit is displayed for 2 seconds.



- Fault codes are displayed at 2 second intervals. When all the fault codes stored in the control unit have been displayed, the buzzer sounds twice and the fault codes are displayed again from the beginning.



Example:

The gear indicator shows

E035 = Fault code 35
003 = Has occurred 3 times

Second depression

- Test of clutch pedal switches and engine signal.

The gear indicator shows:

No indication when the clutch pedal is fully released.

R: The clutch pedal is partially depressed.

RD: The clutch pedal is fully depressed.

*: 0-7 may occur. Used when testing the connection for Scania Diagnos.

E: Engine running.



Third depression

- Test of microswitch (ST1-7) in gear lever.

The gear indicator shows how the microswitches work in different gears.

The upper figure shows where the microswitch starts to have an effect in the different gears.

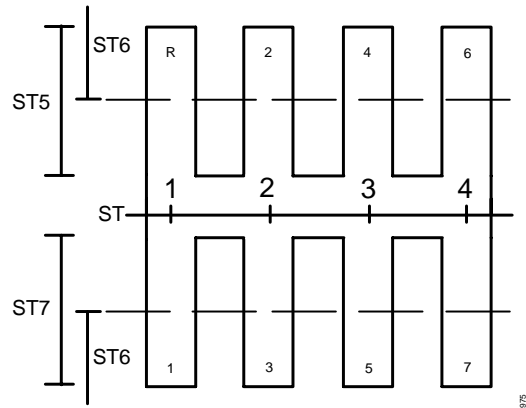

Move the lever to the gear positions and check that the symbols for the different microswitches light up in the gear indicator.

Microswitch 6 is reached when the clutch pedal is depressed so that the interlock valve releases.

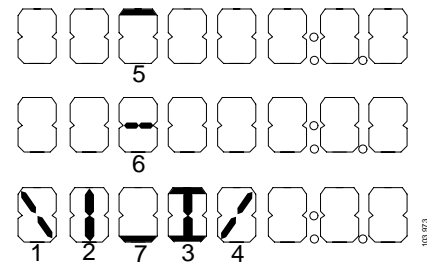

Symbols for the microswitches

Fourth depression

- Test of the gearbox.

The gear indicator displays:

- *) Confirmation from range
 - L = Low
 - H = High
 - X = signal from both high and low range switches, which is wrong
 - Confirmation from left lateral stroke
- B: Confirmation from rearward stroke
- NN: Confirmation from neutral
- F: Confirmation from forward stroke
- R: Confirmation from right lateral stroke



- Control of solenoid valves.
Disengage and engage the gears as follows:

R - (High range)

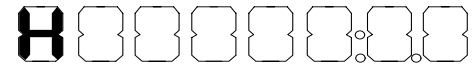

N - (Neutral)



1 - (Low range)

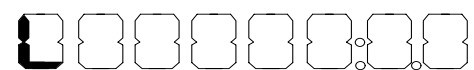

2 - (Left/Forward)

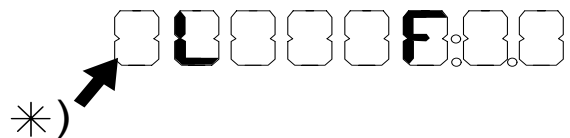

3 - (Left/Rearward)

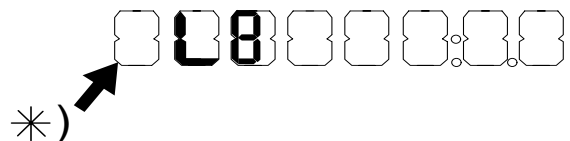

4 - (Forward)

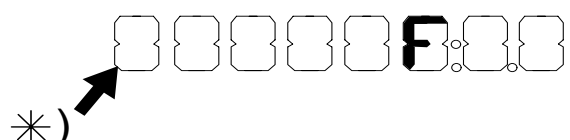

5 - (Rearward)

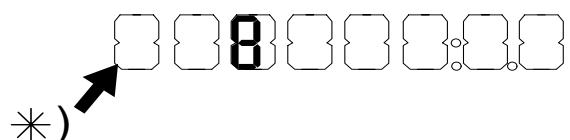

6 - (Right/Forward)

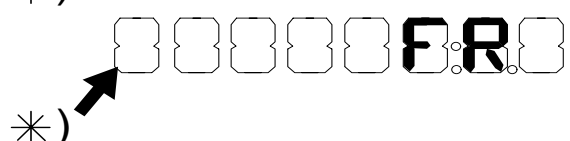

7 - (Right/Rearward) ¹⁾

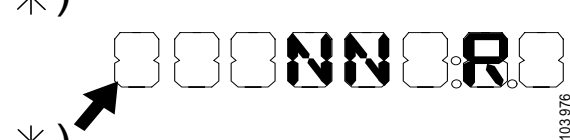

1) The gearbox does not have this position. The gear indicator will show confirmation for Right - Neutral instead.

103976

Fifth depression

- Return to normal operation.
- Return to normal operation takes place if the vehicle moves, regardless of where in the programme you are.

Erasing fault codes

- 1 Switch off the power using the starter key.
- 2 Press and hold the diagnostics switch in the depressed position.
- 3 Turn the starter key to the drive position.
The gear indicator displays "ERASE" as a sign that the fault codes have been erased.



Control unit connections

Input signals

Use	Source	Signal type	Pin
Gives clutch pedal position	Lower pedal switch	+24 V	2
Gives clutch pedal position	Lower pedal switch	+24 V	3
Engine speed = 0	Delay relay	+24 V	7
Confirms rearward longitudinal stroke	Hall effect sensor	+18 V	8
Confirms right lateral stroke	Hall effect sensor	+18 V	9
Gives CS lever's lateral position	Microswitch ST2	+24 V	11
Gives CS lever's end position forward/rearward	Microswitch ST6	+24 V	12
Gives CS lever's position rearward	Microswitch ST7	+24 V	13
Gives vehicle speed	Sensor on output shaft	Frequency	16
Confirms left lateral stroke	Hall effect sensor	+18 V	27
Confirms high range	Confirmation switch, high range	+24 V	28
Confirms low range	Confirmation switch, low range	+24 V	29
Gives CS lever's lateral position	Microswitch ST1	+24 V	30
Gives CS lever's position forward	Microswitch ST5	+24 V	31
Gives vehicle speed	Sensor on output shaft	Frequency	34
Gives CS lever's lateral position	Microswitch ST3	+24 V	36
Activates the test programme	Diagnostics switch	Earthing (0 V)	44
Confirms forward longitudinal stroke	Hall effect sensor	+18 V	45
Confirms neutral position	Hall effect sensor	+18 V	46
Ordering of emergency gearchanging position	Switch in gear lever carrier	+24 V	48
Gives CS lever's lateral position	Microswitch ST4	+24 V	49
Gives clutch pedal position	Upper pedal switch via R515	+24 V	50
Informs whether engine is running	Alternator connection D+, via fuse 22	+24 V	51

Output signals

Use	Destination	Signal type	Pin
Orders rearward longitudinal stroke	Solenoid valve, rearward longitudinal stroke	+24 V	4
Orders right lateral stroke	Solenoid valve, right lateral stroke	+24 V	5
Orders high range	Solenoid valve, high range	+24 V	6
Allows engagement of neutral position	Interlock valve in gear selector housing	+24 V	21
Controls the gear indicator	Gear indicator (in instrument cluster)	Data	22
Orders left lateral stroke	Solenoid valve, left lateral stroke	+24 V	23
Orders low range	Solenoid valve, low range	+24 V	24
Road speed sensor output		PWM	26
Activates the buzzer	Gear indicator (buzzer)	+24 V	40
Orders forward longitudinal stroke	Solenoid valve, forward longitudinal stroke	+24 V	41
Orders neutral position	Solenoid valve, neutral	+24 V	42

Other signals

Use	Source	Signal type	Pin
Earth for control unit	G505	Earth	1
Diagnostics communication	Diagnostics socket, K lead	Data	15
Earth for control unit	G505	Earth	18
Earth for control unit	G505	Earth	19
Power supply for control unit	From delay relay R514	+24 V (U30)	20
Diagnostics communication	Diagnostics socket, L lead	Data	33
Earth for control unit	G505	Earth	37

Circuit diagram

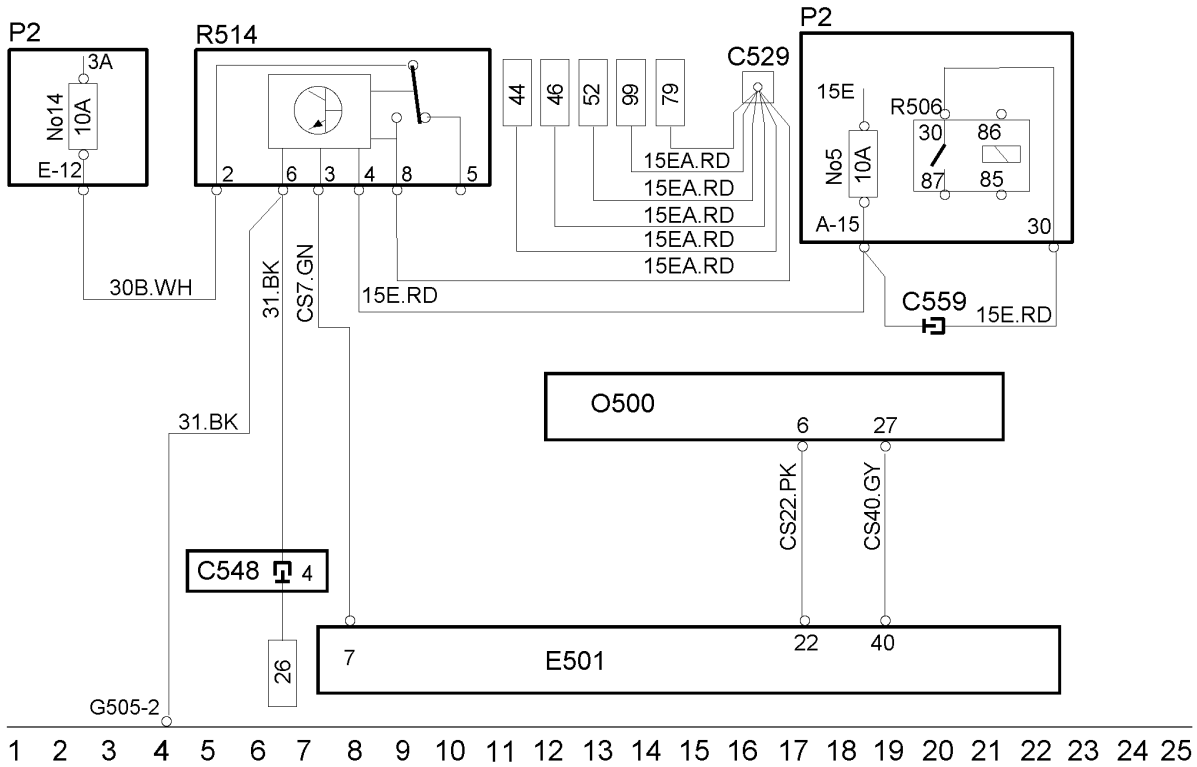

Delay relay, gear indicator

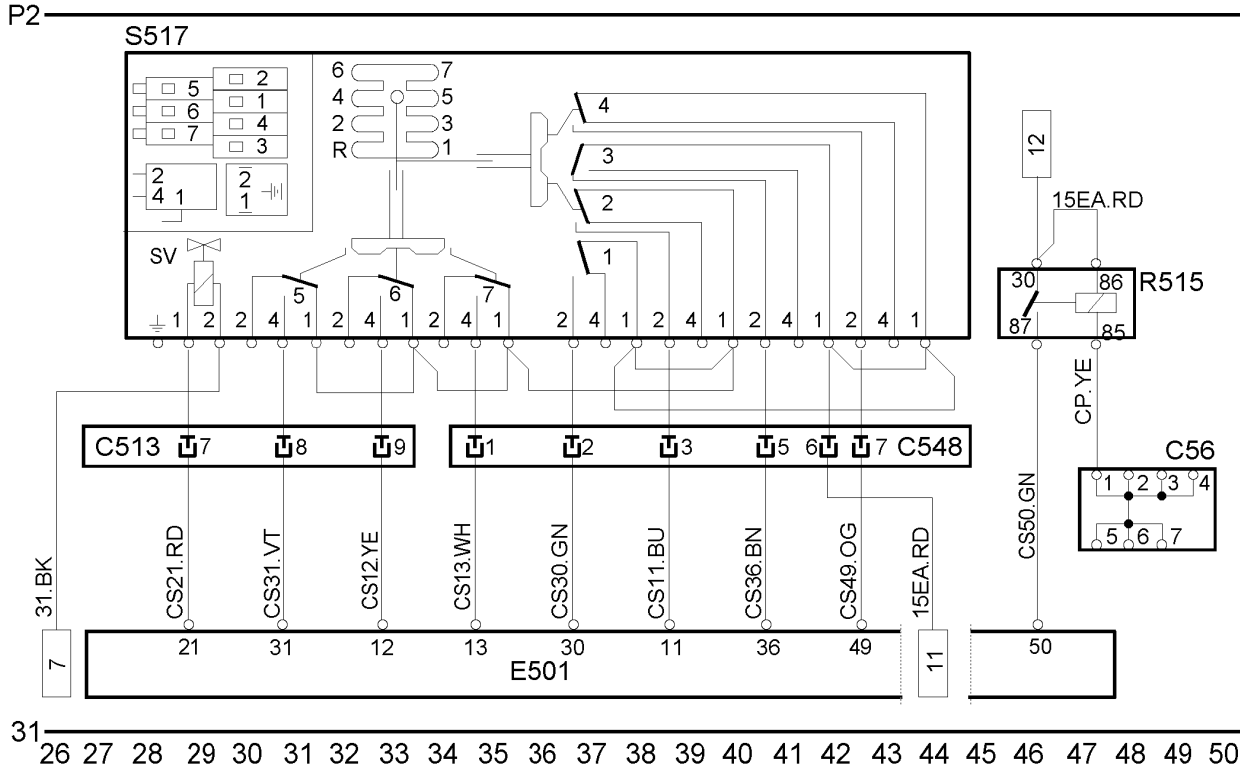

Gear control

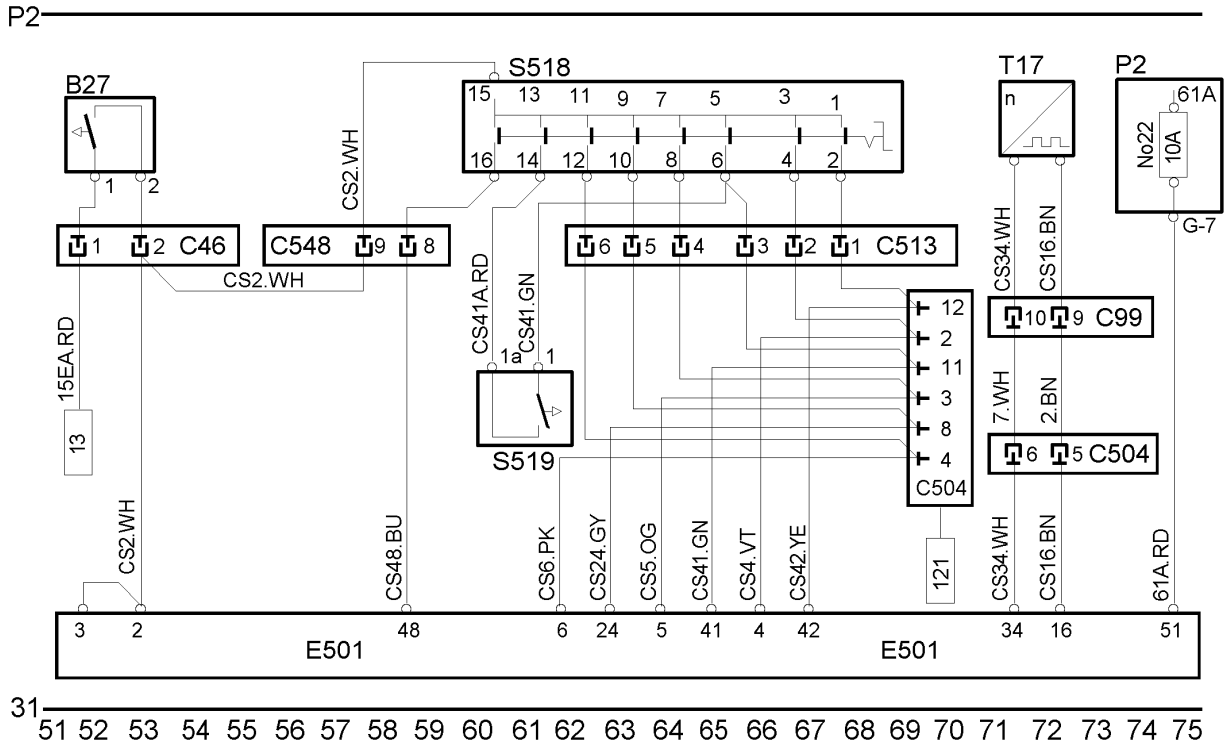

Clutch pedal, emergency gear-changing, road speed sensor

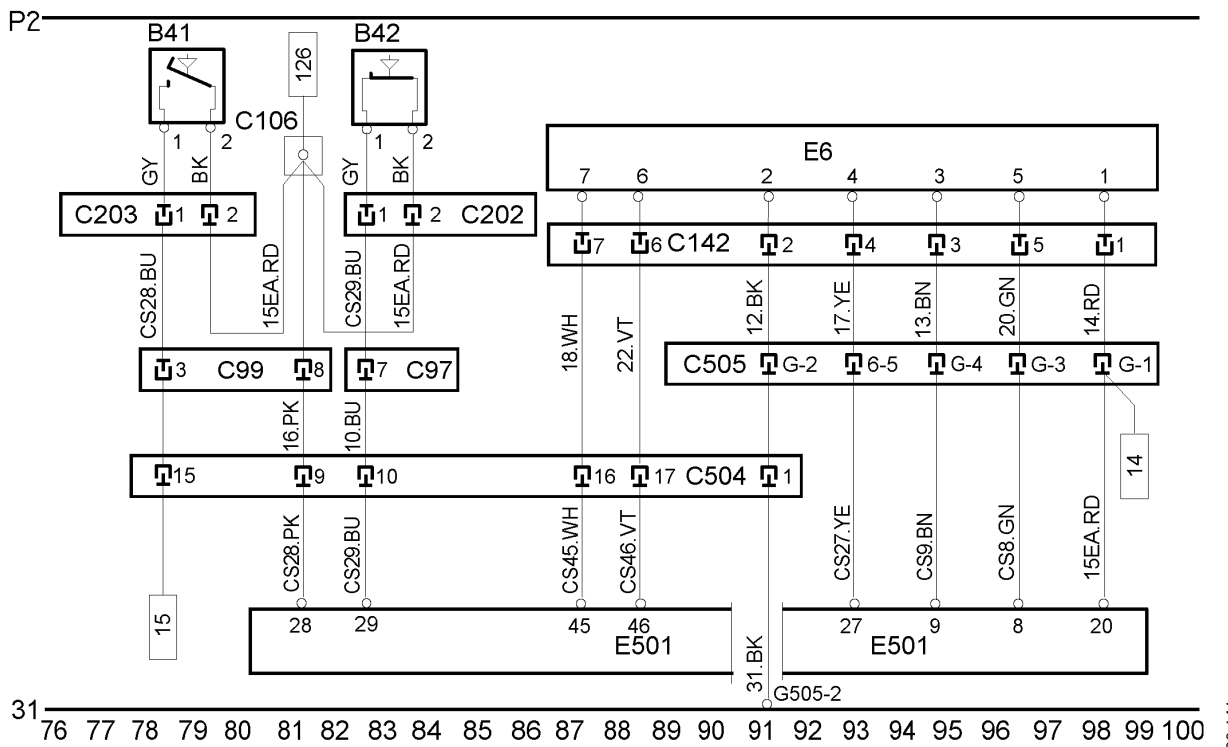

Range switches, hall sensor

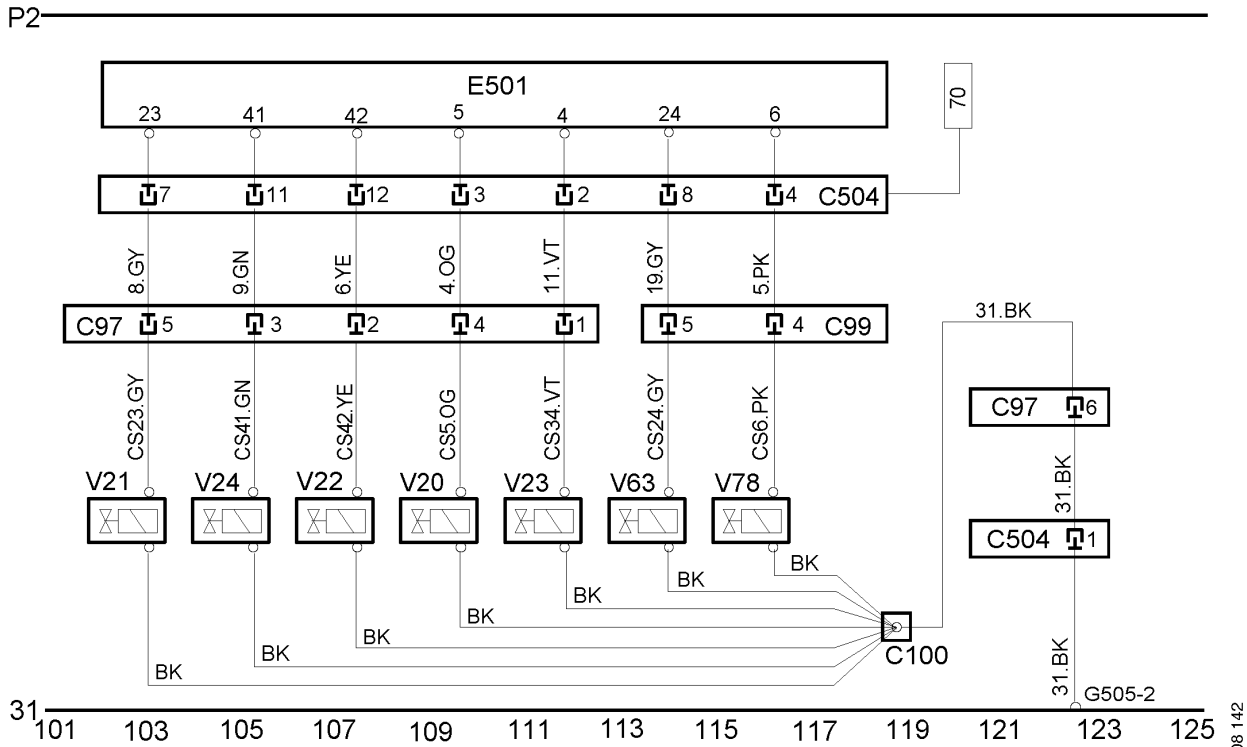

Solenoid valves

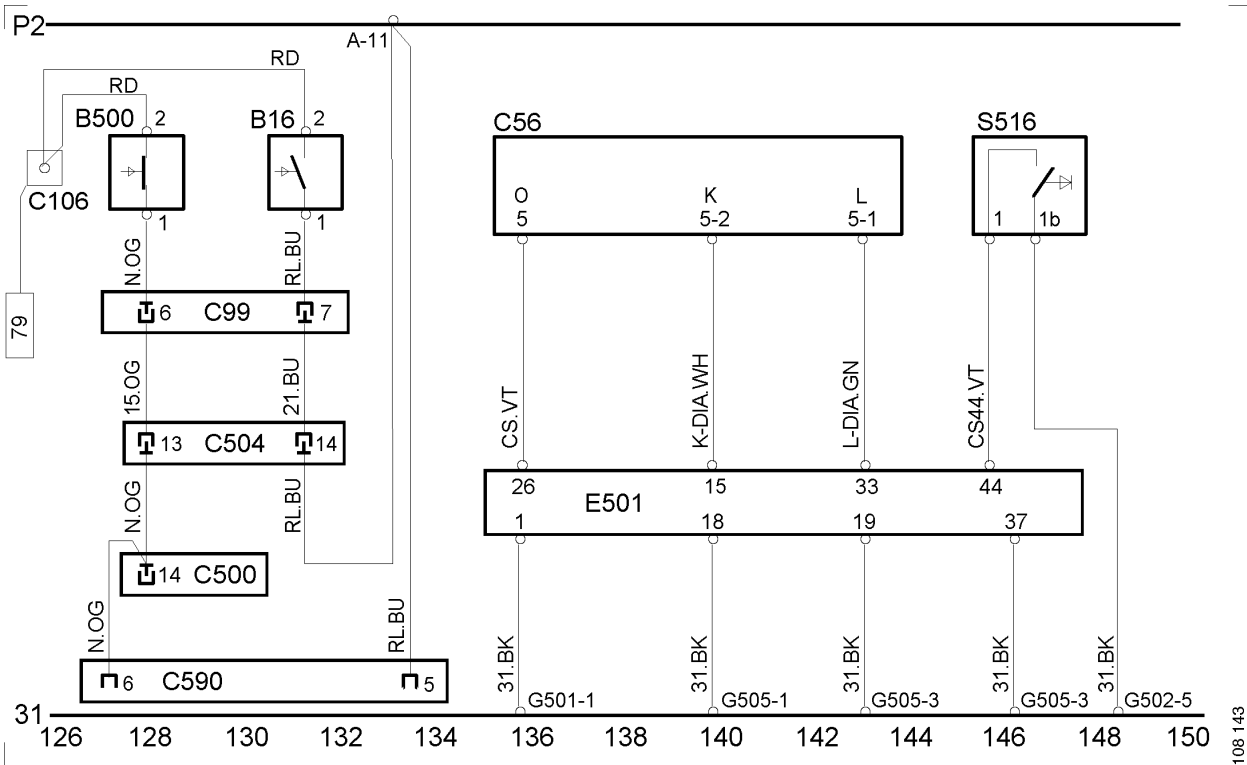

Neutral switch, reversing light switch, diagnostics socket, diagnostic-switch

Trouble shooting

Gear control

Faults in the gear control's microswitches, wiring or connectors can lead to malfunctioning of various kinds.

Symptoms	Open circuit on microswitch (ST)
Selection of 1st gear and R is not allowed.	1
Selection of 2nd and 3rd gears is not allowed.	2
Selection of 4th and 5th gears and N is not allowed.	3
Selection of 6th and 7th gears is not allowed.	4
Selection of 2nd, 4th and 6th gears and R is not allowed.	5
The CS lever is not blocked when the engine has been switched off with a gear engaged.	6
Selection of 1st, 3rd, 5th and 7th gears is not allowed.	7

Symptoms	Short-circuit on micro-switch (ST)
Only 1st gear and R can be selected.	1
Only 2nd and 3rd gears can be selected.	2
Only 4th and 5th gears and N can be selected.	3
Only 6th and 7th gears can be selected.	4
Only 2nd, 4th and 6th gears and R can be selected.	5
No confirmation from the CS lever. The interlock valve is withdrawn and the CS lever enters the drive position before the gearbox has had time to change gear.	6
Only 1st, 3rd, 5th and 7th gears can be selected.	7

Position sensors

Faults such as

- transposed electrical connections,
- interchanged confirmation switches,
- loose contacts

on position switches (confirmation switches/hall sensors) or in their wiring or connectors can result in:

- 1 the control unit failing to recognize an engaged gear. Two dashes will then be displayed in the middle of the gear indicator.
- 2 the control unit recognizing a different gear to the one engaged.
- 3 the control unit being unable to carry out a gear change because of incorrect or absent confirmation.
- 4 clashing of the gears.

In cases 1 and 2 it is common for the control unit, as a consequence of the selected and engaged gear, to perceive these signals differently. The selected gear will then be engaged and disengaged repeatedly as long as the clutch pedal remains depressed.

Incorrectly selected gear-change points cannot be caused by the above faults.

Engine operating mode

The control unit senses through alternator charging whether or not the engine is running.

- 1 Continuous input power results in absence of the warning for engaged gear and switched-off engine.
- 2 An open circuit causes the buzzer to sound continuously when a gear is engaged. The buzzer stops sounding after 5 gear changes.

Road speed sensor

The road speed sensor signal is one of the system's most important input signals and is therefore monitored by two safety functions. Faults in the road speed sensor or its wiring and/or connectors can lead to malfunctioning of various kinds.

- 1 If a short-circuit or open circuit occurs in the sensor or its wiring at high speed, the control unit reacts to what it assumes is excessively rapid deceleration and freezes the engaged gear. Only selection of neutral or a higher gear is then allowed.
- 2 If the above fault already exists when the vehicle is driven off from a standstill, another safety function prevents the driver from selecting a lower gear than the one engaged. The buzzer also sounds a warning.

Faulty road speed information can only affect gear selection, not the gear-changing sequence.

Solenoid valves

If there is a fault in the solenoid valves, wiring, compressed air system or gearbox mechanism, it will only affect the gear-changing sequence. Gears can be selected as usual without trouble.

A fault in the electrical part of the solenoid valve cannot affect an engaged gear until the lower clutch pedal switch is closed (clutch pedal depressed).

Clutch pedal switches

The upper clutch pedal switch connects to earth and activates relay R515 which supplies current to control unit pin 50.

The lower clutch pedal switch applies current directly to control unit pins 2 and 3.

The clutch pedal switches only affect gear selection, not the gear-changing sequence.

A fault in the clutch pedal switches or their wiring and/or connectors could have the following consequences:

- 1 A continuous supply of current from both the lower switch and R515 causes the control unit to believe that the clutch pedal is depressed. It then attempts to change gear as soon as the selected and engaged gears are different.
The driver often discovers the fault because the audible signal, which sounds at the start of a gear-changing sequence, sounds when he preselects the next gear. Sometimes the control unit succeeds in disengaging the engaged gear but as a rule the gear-changing force required is insufficient for engaging the selected gear as the clutch pedal is in the released position (clutch engaged).
- 2 Gear-changing never takes place if there is an open circuit in one of the switches.
- 3 Current from R515 but not on the lower switch for more than ten minutes causes the buzzer to sound and enables the driver to change up and engage neutral.

- 4 Current on the lower switch but not from R515 causes the buzzer to sound after one second and enables the driver to change up and engage neutral.

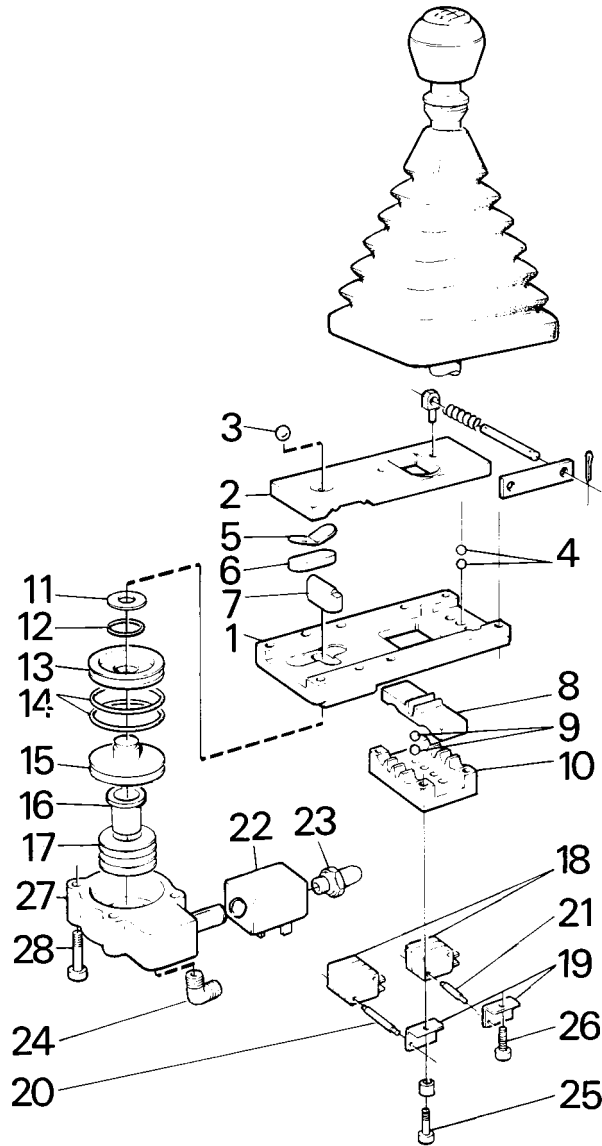

108:250

- | | | | |
|----|--------------|----|------------------|
| 1 | Frame | 15 | Piston |
| 2 | Slide | 16 | Guide |
| 3 | Steel ball | 17 | Disc spring |
| 4 | Steel balls | 18 | Microswitch |
| 5 | Spring | 19 | Holder |
| 6 | Key | 20 | Pin |
| 7 | Detent | 21 | Pin |
| 8 | Catch | 22 | Solenoid valve |
| 9 | Steel balls | 23 | Silencer |
| 10 | Coulisse | 24 | Elbow union |
| 11 | Steel washer | 25 | Bolt |
| 12 | O-ring | 26 | Bolt |
| 13 | Cover | 27 | Cylinder housing |
| 14 | O-ring | 28 | Bolt |

Gear control

Mechanical work

Gear control

Detaching the CS lever

- 1 Remove the bolts and remove the boot and cover from the mode selector housing.

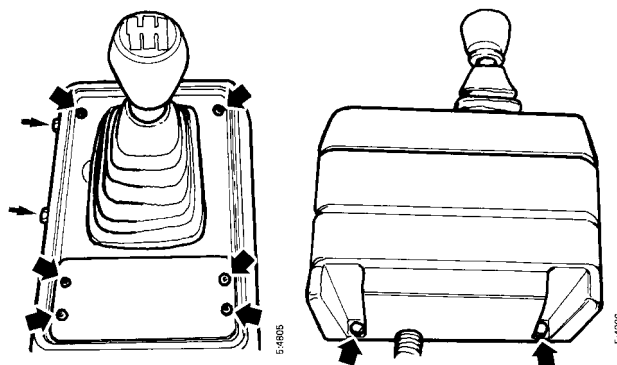

- 2 Remove the clamps and air lines 1 and 2.
- 3 Unplug all electrical connectors from the CS lever housing.
- 4 Unscrew the four bolts 3 and remove the gear control from the bracket.

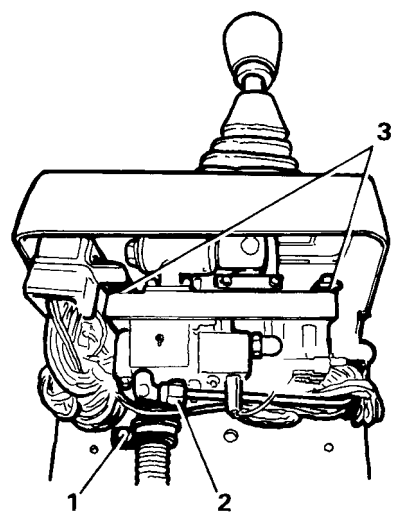

Fitting

- 5 Connect the lines and connectors to the new gear control.
- 6 Screw the gear control in place with the four bolts. Fit a washer between each bolt and the bracket,
- 7 Bolt the outer casing and cover in place.

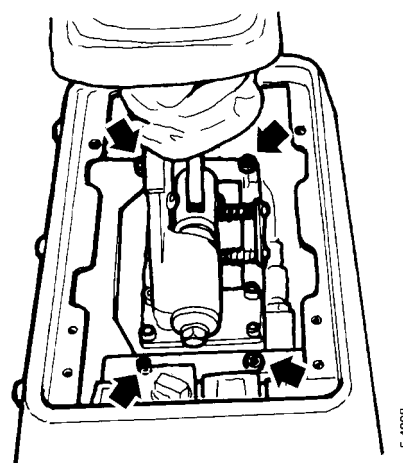

Operational test

Check that the lever moves easily sideways, that the latch for position R/1 works and that the lever automatically assumes position N (4/5) when it is not actuated.

Equipment: Compressed air at least 6 bar
24 V via a switch

Leakage: With the compressed air supply connected and the valve closed, no sound of leakage should be heard.

Check all gear positions as follows:

- 1 Connect 24 V via a switch to the two parallel pins on the solenoid valve and connect compressed air.
- 2 When the valve is not supplied with current it should be easy (max. 30 N) to move the lever to each gear position.
- 3 When the valve is supplied with current it should be possible to move the lever to the drive position.
- 4 Cut off the current supplied to the valve. The lever should now be locked in place and immovable against a force of 200 N.

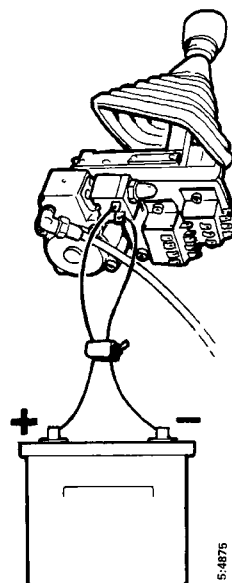

Figures and designations refer to the exploded view drawing of the gear control.

Dismantling

- 1 Take the gear control out of the lever housing and clamp it in a vice.
- 2 Unscrew the six socket cap screws and remove the CS lever.

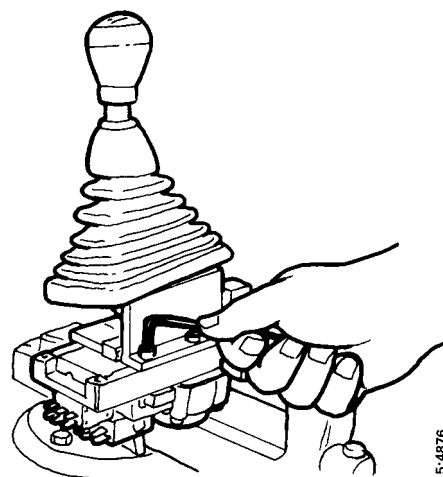

- 3 Remove ball 3 and slide 2.

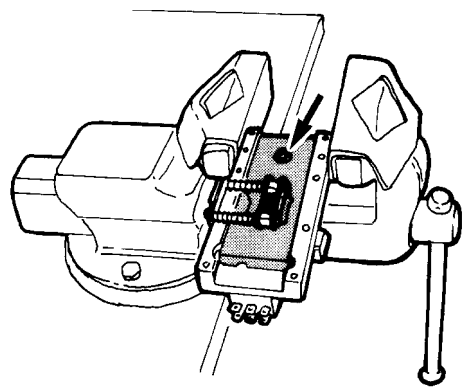

- 4 Remove key 6 and spring 5.
- 5 Remove detent 7.
- 6 Remove steel balls 4, 3+3 pieces, from under microswitches ST 5, 6 and 7.

Note: Be careful and make sure that the steel balls do not disappear.

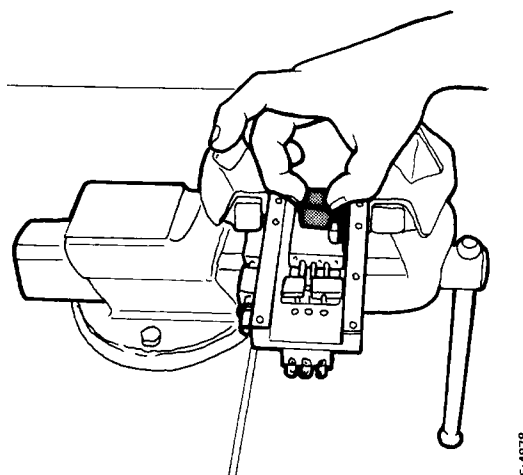

- 7 Invert the frame so that the microswitch sections and cylinder are uppermost.

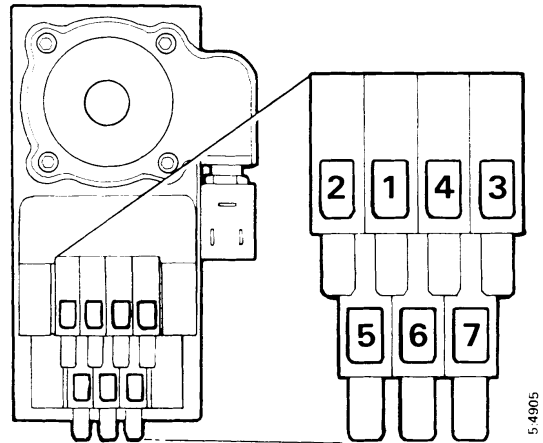

- 8 Unbolt and lift out the two microswitch sections.

The sections can be dismantled so that individual microswitches can be changed.

- 9 Remove the eight (4+4) steel balls 9 under microswitches ST 1, 2, 3 and 4.
- 10 Remove coulisse 10 and catch 8.
- 11 Make a mark on cylinder housing 27 with a pen to indicate the way it is mounted. It is to be refitted later in the same way.

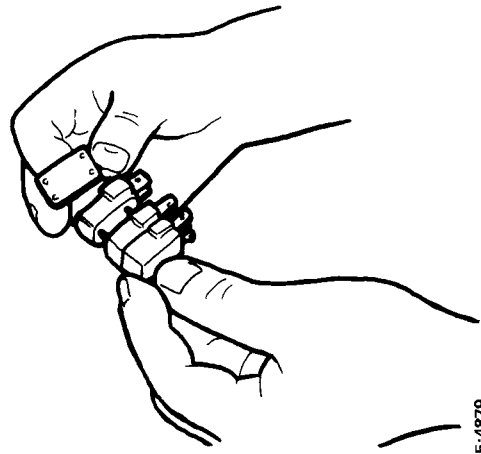

- 12 Undo the four cylinder housing bolts 28.

Note: Remove the cylinder housing, keeping it straight so that it does not tilt against the piston inside it.

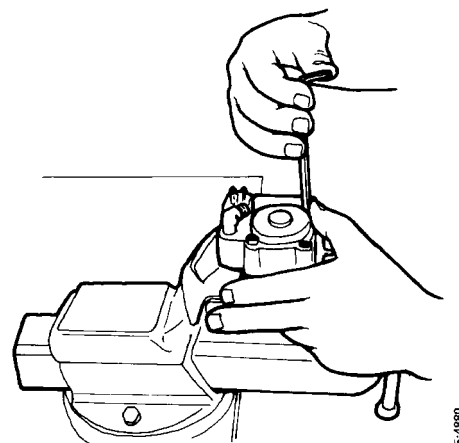

- 13 First unscrew only two diagonally opposite bolts. Then unscrew the two other bolts alternately half a turn at a time.
- 14 Remove washer 11.
- 15 Clamp the cylinder in a vice (not too hard).

- 16 Lift off cover 13.
- 17 Press out piston 15 from the underside of the cylinder housing or by lifting from the dowel on the top.

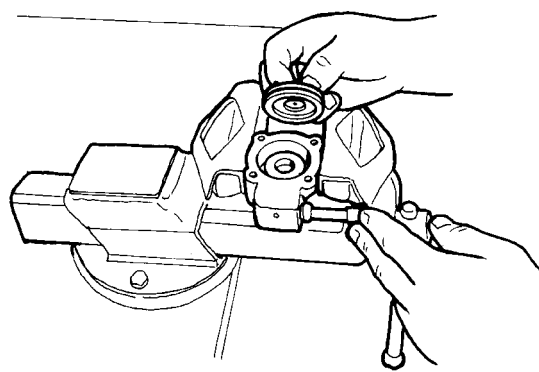

- 18 Remove washers 17 from the cylinder housing together with guide 16.
- 19 Inspect the surface of the cylinder housing's inner wall. If necessary, clean the surface with fine emery cloth so that the piston's O-ring will not be damaged on reassembly.

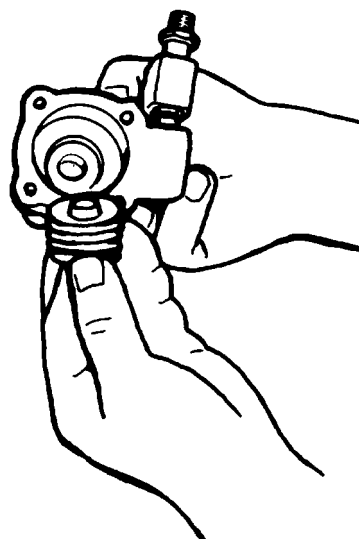

Assembly

When greasing:

Use air grease, part No. 319 308, round O-rings 14 and 12 and Universal grease for other parts.

- 1 Fit disc springs 17 on guide 16. Place a single disc spring with the concave side facing outwards at both ends. The other springs should be fitted in pairs as shown in the figure.
- 2 Clamp the cylinder in a vice.
- 3 Fit the disc springs in the cylinder housing. Centre them by means of the guide.
- 4 Fit the O-rings in both piston and cover. Grease them as above.
- 5 Press piston 15 down against the spring assembly. Press on it to make sure that it feels springy.
- 6 Place the cover over the piston and press it home by hand with even pressure until it rests against the piston.

Note: Exercise care when compressing the spring assembly. If any of the springs tilts the cylinder and/or springs could be damaged.

- 7 Clamp frame 1 in a vice.
- 8 Fit washer 11 in cover 13.

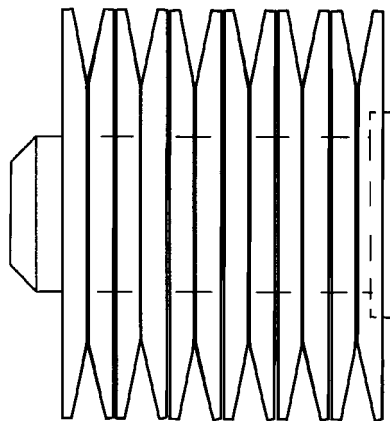

05_4883

- 9 Fit the cylinder, making sure that it is correctly positioned. Secure it with only two diagonally opposite bolts so that it lies flat against the frame. Tighten the bolts alternately only half a turn at a time, checking from time to time that the cylinder is centred and bolted down evenly.

Tighten these two bolts.

- 10 Check that the piston can move.

Connect compressed air to the elbow union on the cylinder and 24 V via a switch to the solenoid valve's parallel pins.

Switch the current on and off again and check that the piston's stroke is 2.8 ± 0.1 mm.

- 11 Tighten the two remaining bolts on the cylinder housing.

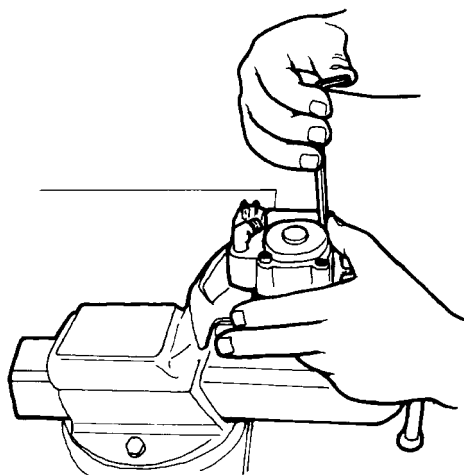

5-4880

- 12 Grease the catch, coulisse and support lugs. Place catch 8 in coulisse 10. Make sure that the grooves in the catch and the coulisse are in alignment to accommodate the CS lever's guide.

- 13 Turn the coulisse with catch upside down and place them on the frame.

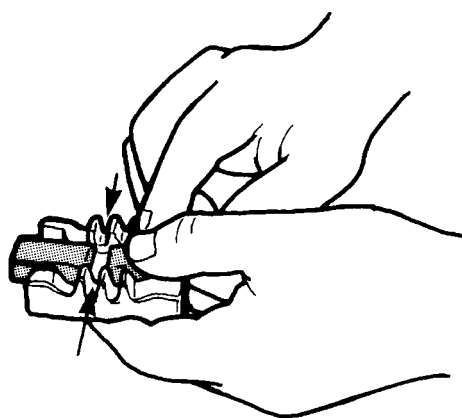

05_4884

- 14 Screw a bolt with sleeve in the hole beside the solenoid valve. The sleeve prevents the solenoid valve from being turned in towards the gear control.
- 15 Tighten the bolt in the hole beside the cylinder.
- 16 Clean and wipe dry the eight (4+4) steel balls 9 and also the contacts of microswitches ST 1 - 4. Fit the balls in place.
- 17 Hold the larger microswitch section together. Use bolts 25 as guides and fit the section on the coulisse. Tighten the bolts and make sure that neither the microswitches nor the retaining plates turn relative to each other when tightened.
- 18 Fit microswitches 5-7 in the same way as described in point 17.
- 19 Invert the gear control.
- 20 Fit the six steel balls 4 for microswitches ST 5 - 7.
- 21 Grease detent 7 and fit it in the frame.
- 22 Fit key 6 on the detent's shoulder.
- 23 Grease the tips of the upturned side of spring 5 and press it into its groove in slide 2.

Note: The way the spring fits in its groove is important. The tips should be angled upwards towards the groove in the slide.

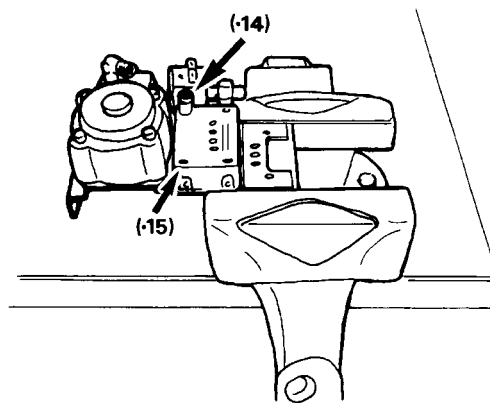

5-4885

- 24 Place the slide on the frame.
Take care to position the slide's groove over the key.
- 25 Place ball 3 in position and grease it.
- 26 Fit the lever part and secure it with five retaining bolts.

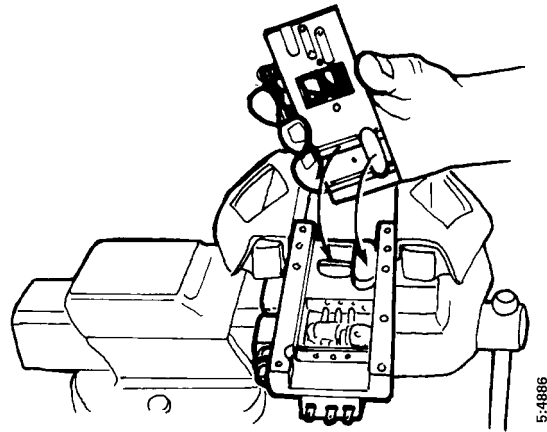

Solenoid valve

Figures and designations refer to the exploded view drawing of the gear control.

Dismantling

- 1 Undo union 23 and remove the coil. Check the valve part's protective sleeve to make sure that it is not bent or cracked.

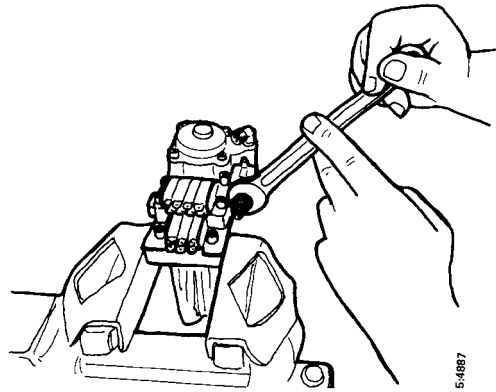

- 2 Unscrew the valve part at the bottom plate (bolts) or at the nut.

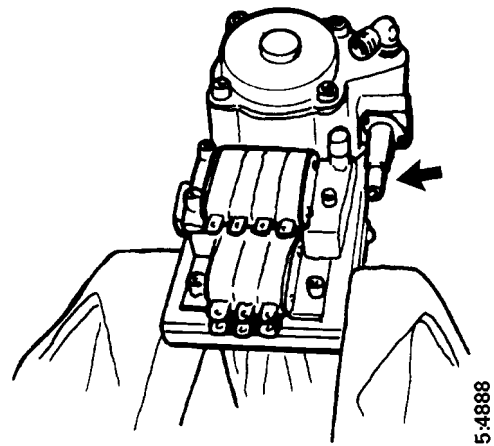

Assembly

- 1 Bolt the valve part to the cylinder housing.
- 2 Fit the solenoid coil on the valve part.
- 3 It is important to fit the spring washer in the recess on the outside of the coil before fitting the flat washer.
- 4 Screw the union into the solenoid valve. Be careful with the guide for the washers. Tighten the union carefully until the washers have been guided into place correctly.

Note: Tighten only so hard that the solenoid valve cannot be turned round with moderate finger strength.

Checking wear

Figures and designations refer to the exploded view drawing of the gear control.

- 1 Check catch 8 if the groove in its edges is damaged. Change the catch if necessary.
- 2 Check the shoulders of coulisse 10 for wear. Change the coulisse if necessary.
- 3 Check spring 5 for damage. Change the spring if necessary.
- 4 Check whether detent 7 has been seated askew and sustained damage. Change the detent if necessary.
- 5 Check whether any of microswitches 18 are damaged. Change as necessary.
- 6 Check whether the edges of the end of the CD lever towards coulisse 10 are sharp. Clean the edges if necessary.
- 7 Change the O-rings on cover 13 and piston 15.

Checks and settings

Position sensors

The integral test programme is used to check the operation of the position sensors.

Hall effect sensor

The position of the hall sensor is checked with the gear shift housing removed from the gearbox. For checking and setting, see gear shift housing, Opticruise and CS.

Confirmation switches

The confirmation switches should not be set. Simply check that they are working.

Designation	Function
B41	High range
B42	Low range

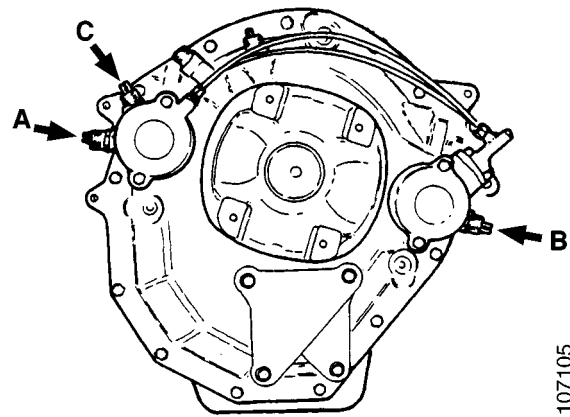

107105

- A = High range switch (B41)*
- B = Low range switch (B42), gearbox without Scania retarder*
- C = Low range switch (B42), gearbox with Scania retarder*

Confirmation switches on range part.

Solenoid valves

Change gear with the engine switched off, the starter key in the drive position and operating pressure in the compressed air system.

Check all gear positions with the gear indicator by preselecting and then depressing the clutch pedal.

If no gear can be engaged, it may be because the gear teeth are not in mesh. In such case, try releasing the parking brake and depressing the clutch pedal again.

If this does not help, select neutral and start and stop the engine. Then engage the gear that could not be engaged earlier.

If two or more gears cannot be engaged, check the solenoid valves according to the table under specifications. Their location in the vehicle is given under the heading "Location of gearbox components" and shown in the position illustrations in this booklet.

Note: The solenoid valves are supplied with current only as long as the clutch pedal is depressed.

If no gear-changing takes place, check the clutch pedal switches.

Gear-changing pattern

Since a vehicle with Comfort Shift is equipped with a manual gearbox, the gears have the same pattern of movement as the gear selector.

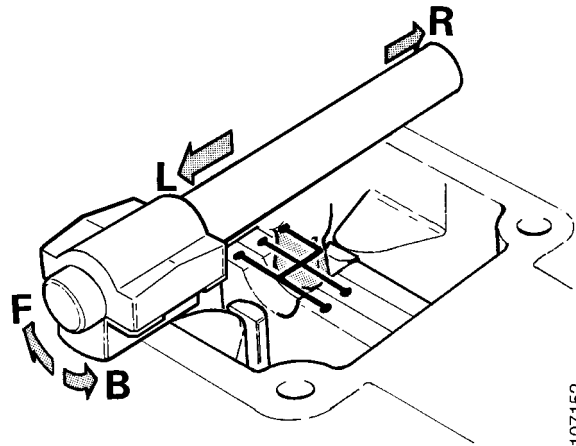

107152

Gear-changing movements and confirmations

The following table shows:

- gear-changing movements from the neutral position
- the solenoid valves which are activated when a gear is engaged.

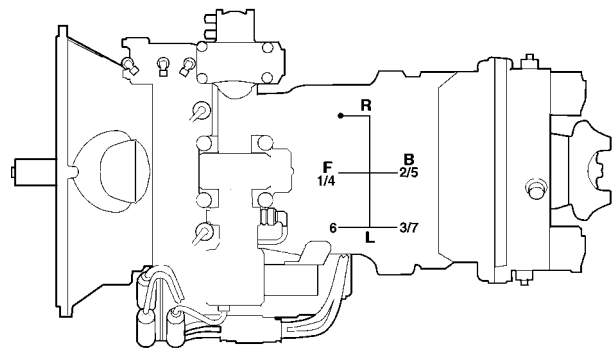

107106

L = Left
R = Right
F = Forwards
B = Backwards

Gear selector movement pattern, GR801

Selected gear	Gear in gearbox	Gear-changing movements		Gear-changing Working solenoid valves and position sensors	
		Lateral-stroke	Longitudinal stroke	Main box	Range High/Low gear
N	N	Centre	Centre	V22-N	V78-B41/V63-B42
R	RL	R	F	V20-NR V24-FR	V63-B42
1	1L	Centre	F	V22-N V24-F	V63-B42
2	2L	Centre	B	V22-N V23-B	V63-B42
3	4L	L	B	V22-N V21-NL V23-BL	V63-B42
4	1H	Centre	F	V22-N V24-F	V78-B41
5	2H	Centre	B	V22-N V23-B	V78-B41
6	3H	L	F	V22-N V21-NL V24-FL	V78-B41
7	4H	L	B	V22-N V21-NL V23-BL	V78-B41

Location of gearbox components

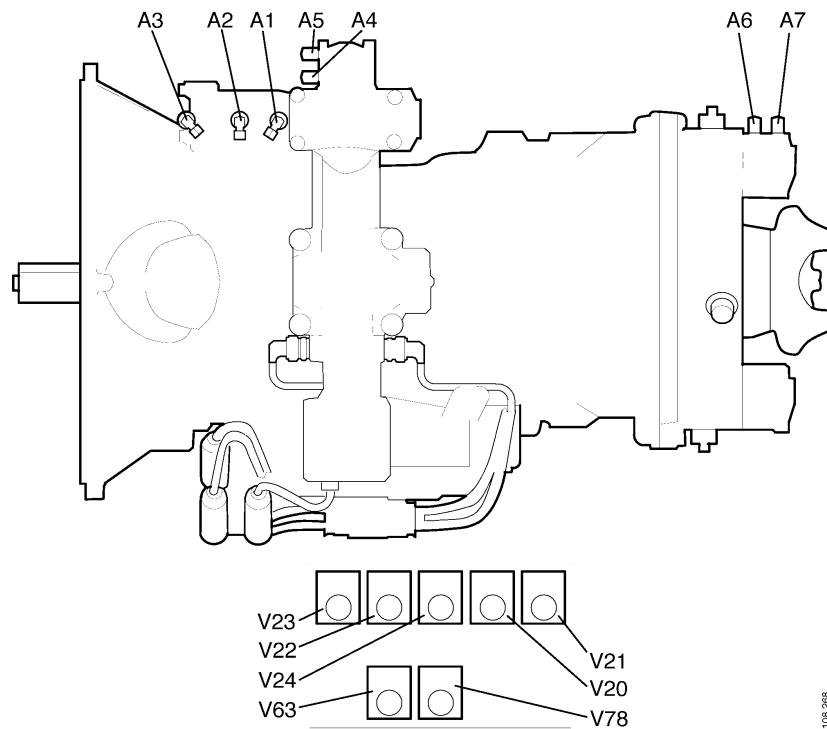

108 268

Solenoid valves

Designation	Function	Connection
V20	Lateral stroke, right	A5
V21	Lateral stroke, left	A4
V22	Lateral stroke, neutral	A2
V23	Lateral stroke, back	A1
V24	Lateral stroke, forward	A3
V63	Range, low	A6
V78	Range, high	A7

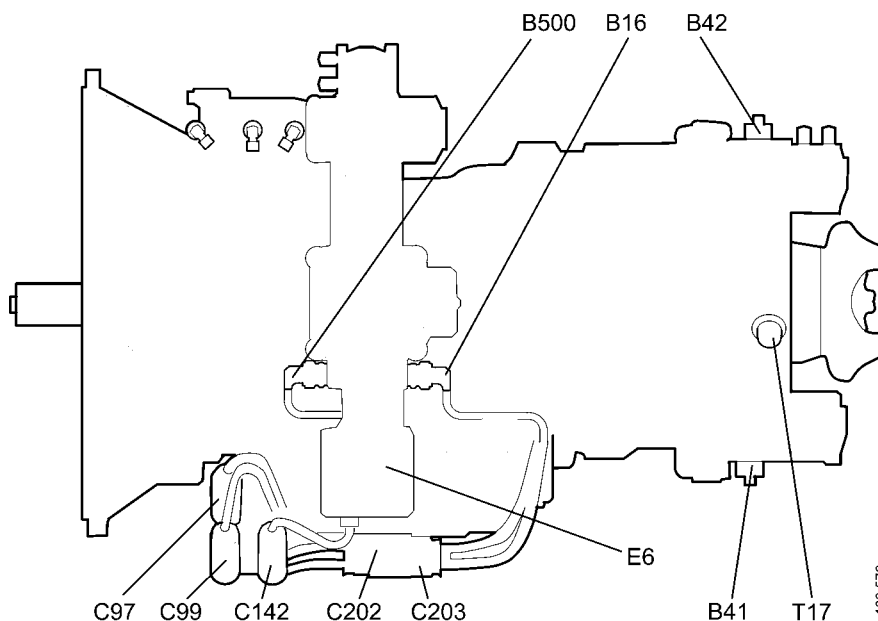

Switches

Designation	Function
B16	Reversing lights
B500	Neutral position - gearbox

Connectors

Designation	Function
C97	7-pin
C99	10-pin
C142	7-pin
C202	2-pin
C203	2-pin

Position sensors

Designation	Function
E6	Right
	Left
	Rearward
	Neutral
B41	Range, high
B42	Range, low

Speed sensing

Designation	Function
T17	Speed sensor

Specifications

Settings

Page

Piston in gear control 2.8 ± 0.1 mm

51

Fluids and lubricants

Universal grease See group 0

Code plugs for control unit

Part No.	Engine	Engages low range in reverse gear
1 303 044	All	X