

SCANIA

10:03-08

Issue 1 en

Testing brake system

Applies to vehicles with EBS



122 392

cardiagn.com

Contents

General	5
Equipment	6
Location of components	12
Test connection	14
Checking pressure gauges	16
Operating pressure, integrity, overflow valve	Test stage 1 20
Anti-freeze unit	Test stage 2 24
Four-circuit protection valve, types 1, 3	Test stage 3a 26
Four-circuit protection valve, types 2, 4, 5	Test stage 3b 30
Parking brake, emergency brake, pressure limiting valve 58b, relay valve	Test stage 4 34
Fault codes, Configuration	Test stages 5 and 6 38
Lining wear sensor	Test stage 7 42
Checking warning lamps, sensors	Test stage 8 44
Pedal position sensor	Test stage 9 46
Load sensing pressure sensor	Test stage 10 48
Communication	Test stage 11 52
	Signal from exhaust brake to EBS 2.2 52
	DBR Signal 53
	Engine, torque limitation 54

Service brake valve	Test stage 12	56
Brake starting pressure	Test stage 13	58
Control modules	Test stage 14	60
Trailer relay valve	Test stage 15	62
Trailer control module, TCM, EBS 2.2	Test stage 16	64
Trailer relay valve/control unit, discharge function	Test stage 17	66
Communication with trailer equipped with EBS	Test stage 18	68
Secondary brake valve, T-vehicles 4x2, EBS 2.2	Test stage 19	69
Wheel sensors	Test stage 20	70
Retarder torque	Test stage 21	72

General

The illustrations contained in this booklet originating from Scania Diagnos are from version 2.14. The layout may differ in new versions of Scania Diagnos.

IMPORTANT! Make sure the pressure gauges being used are checked and calibrated.

EBS components

- Many components and their functions can easily be checked using the Read/Activate function in Scania Diagnos.

The help button in each diagnosis window will display a description of what the different buttons are used for.

Note: The layout of the diagnosis window will also differ depending on the EBS system being tested.

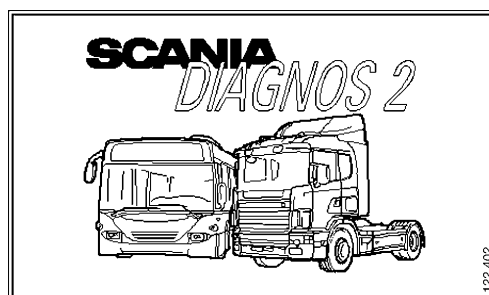

Equipment

1 Measuring panel 98 600

- Panel comprising three pressure gauges, 0-2.5 bar, fitted in a metal case.
- A Plexiglas disk permanently screwed to the metal casing protects the pressure gauges from the front. The connection to each pressure gauge contains a damping device and a T-pipe equipped with a 3/8" insert nipple and a safety valve set to 2.5 bar.

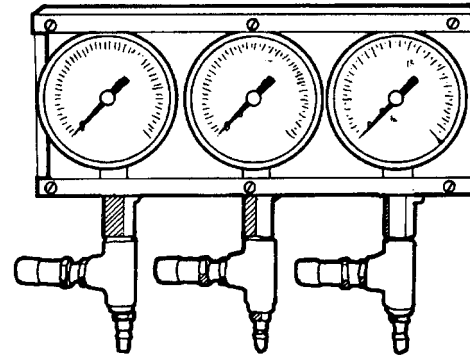

2 Measuring panel 99 399

- Two built-in pressure gauges, 0-15 bar, without safety valve.

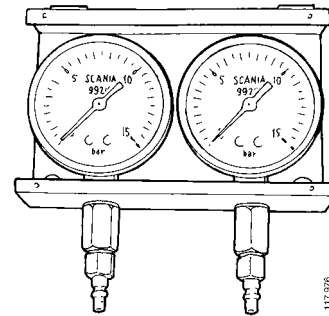

3 Pressure gauge 99 215

- A loose pressure gauge 0-15 bar, without safety valve.

99 215

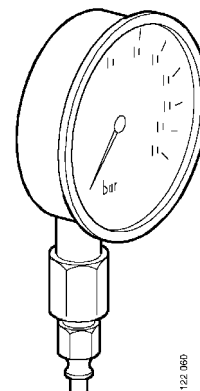

4 Relief valve 98 703

- The relief valve is designed to control the other pressure gauges.

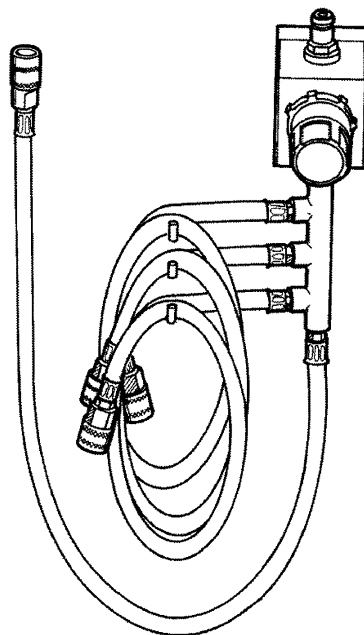

b113674

5 Adapter 99 401

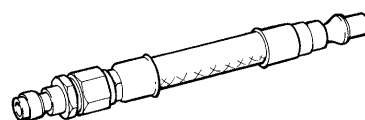

99 401

122 374

6 Pressurising hose with connections, 98 243

- The hose is equipped with a cap nut at one end and a threaded adapter connection at the other. It also has a check valve and a test connection. The hose is used when charging the compressed air system of the vehicle with workshop air.

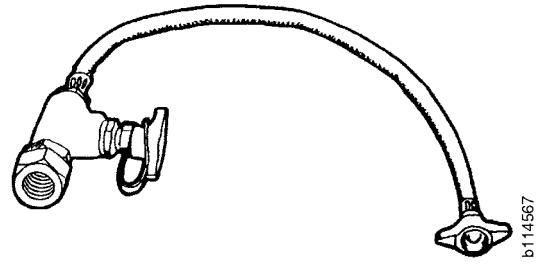

7 Connector for connecting hose 98 706

- These connectors are used for linking connection hoses for trailer brake tests etc.

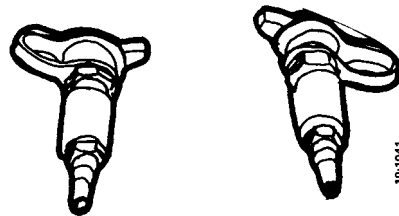

8 Connection hose 99 164

- Fabric-reinforced plastic hose with cap nut at one end and quick coupling at the other. The hoses are used to connect the pressure gauges to the test connections. The hoses can be joined using connector 98 706 when testing trailer brakes etc.

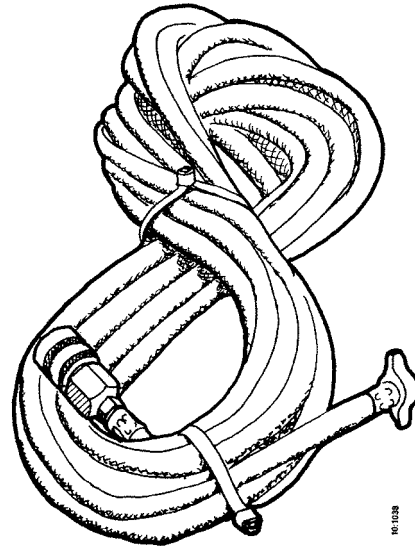

9 In-house manufactured tools

Duo-Matic, ISO and BSI kits can be ordered to brake testing trolley 588 477. See tool sheet 588 477 for component parts.

Due to the various designs of trailer brake couplings, hoses 98 605 are supplied without couplings. Connect the couplings as follows:

- **Duo-Matic fittings:**

Drill out the rivets holding the plate on the cover using a 5 mm drill. Cut a thread using an M6 tap and attach the handle with an M6x12 mm bolt. Make two versions, one for trucks and one for tractors. Use handle 99 402 for trucks.

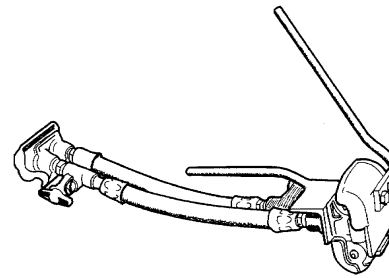
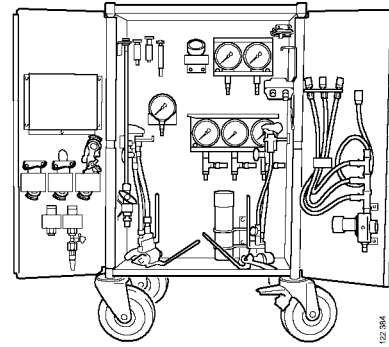

- **ISO connection:**

Use a T-union WR 1/4" and test connection 215 619.

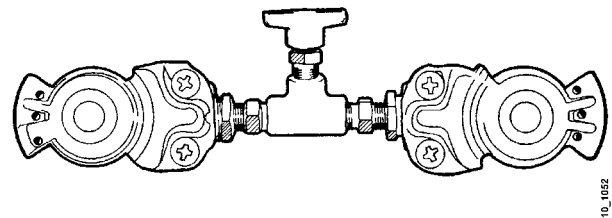

- **Duo-Matic coupling, trailer section**

Equipped with a test connection in the feed line connection.

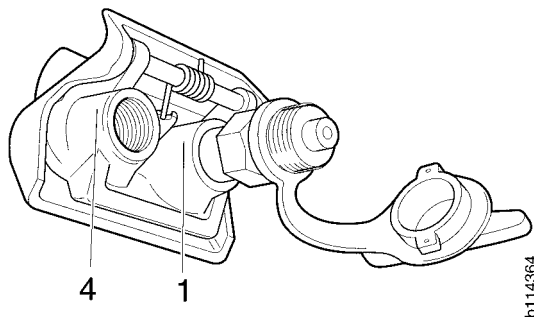

*1 Feed line
4 Control line*

- **ISO connection, trailer section**

Equipped with a test connection in the feed line connection.

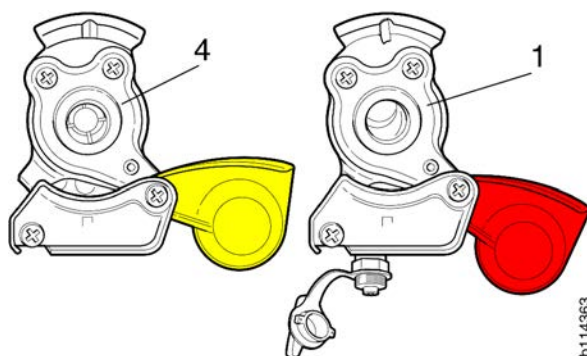

*1 Supply cable (red)
4 Control cable (yellow)*

- **BSI connection, trailer section**

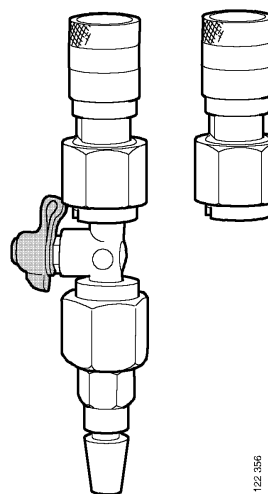

Location of components

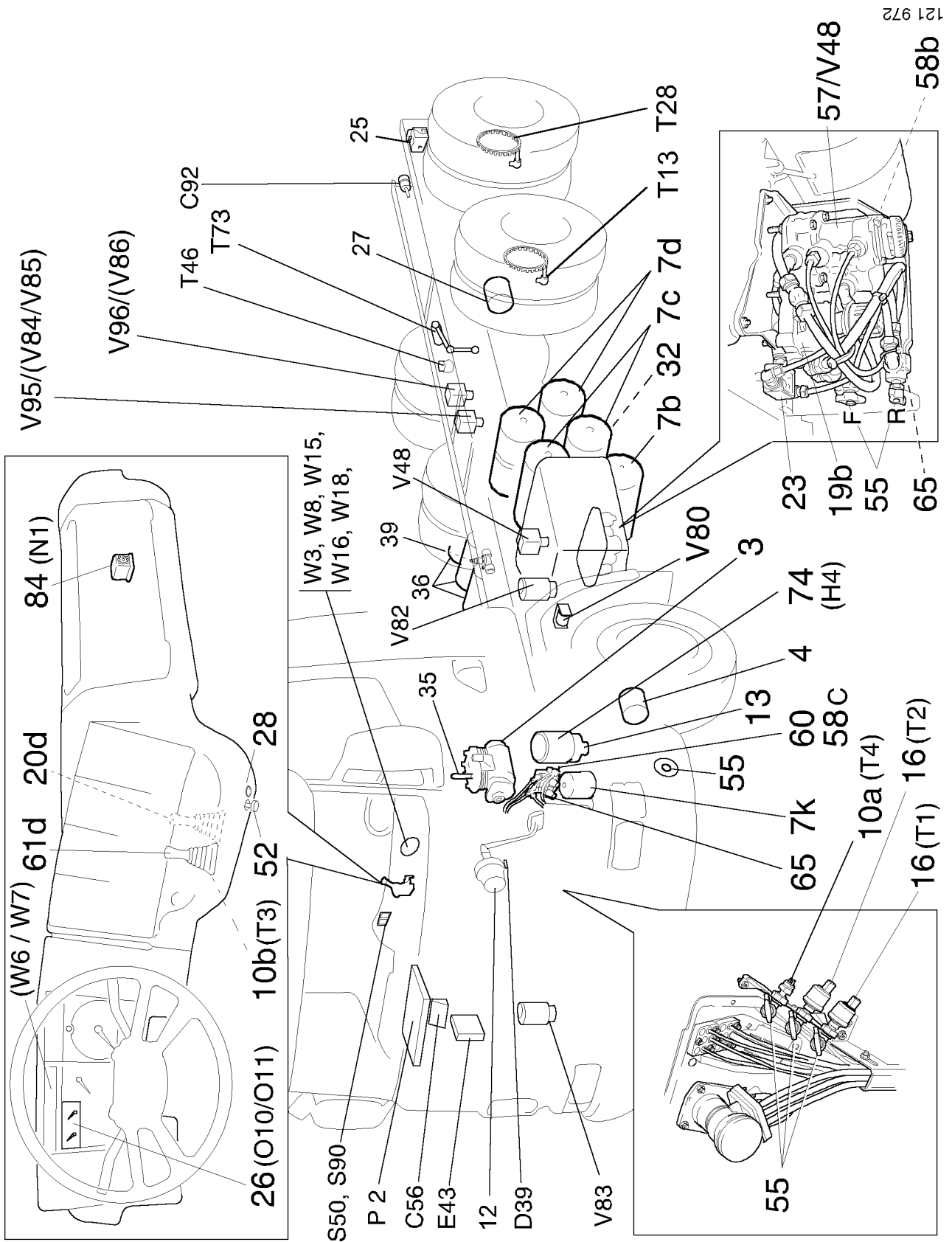

121 972

cardiagn.com

3	Compressor		V83	Control module, axles 1 and 4, right-hand side
4	Brake chamber		V84	Control module, axle 2, left-hand side
7b	Air tank, parking and trailer brake circuits		V85	Control module, axle 2, right-hand side
7c	Air tank, front circuit		V86	Control module, axle 3
7d	Air tank, rear circuit		V95	Control module, axle 2, EBS-2.2
7k	Air tank, air dryer		V96	Control module, axle 3, 6x4, EBS-2.2
10a (T4)	Low pressure indicator for supply pressure, parking brake circuit		W3	Warning lamp, TC
10b (T3)	Low pressure indicator for service pressure, parking brake circuit		W6	Warning lamp, low circuit pressure
12	Service brake valve		W7	Warning lamp, parking brake
13	Safety valve (14.3 bar)		W8	Warning lamp, ABS/EBS
16	(T1) Pressure sensor with monitor, front circuit		W15	Warning lamp, ABS/EBS, trailer
16	(T2) Pressure sensor with monitor, rear circuit		W16	Warning lamp, trailer without ABS/EBS
19b	Relay valve, parking brake circuit		W18	Warning lamp, worn brake pads
20d	Manual control valve, trailer brake circuit			
23	Double check valve			
25	Trailer brake coupling			
26	(O10) Indicating instrument, front circuit pressure			
26	(O11) Indicating instrument, rear circuit pressure			
27	Spring brake chamber			
28	Filler nipple, parking brake circuit			
32	Drain valve			
35	Safety valve, 19 bar			
36	Air tanks, air suspension			
39	Overflow valve			
52	Interlock valve			
55	Test connection, filler nipple			
57	Trailer relay valve			
58b	Pressure limiting valve (8 bar), parking and trailer brake circuit (7.3 bar for US-adapted brake systems)			
58c	Two-stage pressure limiting valve (9.3 bar) for 12.2 bar systems			
60	Four-circuit protection valve			
61d	Manual control valve, parking brake circuit			
65	Manifold fitting			
74	(H4) Air dryer with integrated pressure regulator			
84	(N1) Buzzer			
C56	Junction block, CAN signals			
C92	Trailer coupling			
D39	Pedal position sensor			
E43	EBS control unit			
P2	Central electric unit			
S50	Diagnostics panel			
S90	TC-Off Road switch			
T13	Wheel sensor			
T28	Wheel sensor			
T46	Load sensing pressure sensor			
T73	Air suspension level sensor			
V48	Trailer control module, TCM			
V80	Secondary brake valve			
V82	Control module, axles 1 and 4, left-hand side			

Test connection

A colour-coded brake circuit diagram is available in the electronic version of this booklet as well as in main group 10, Testing brake system, Test connection

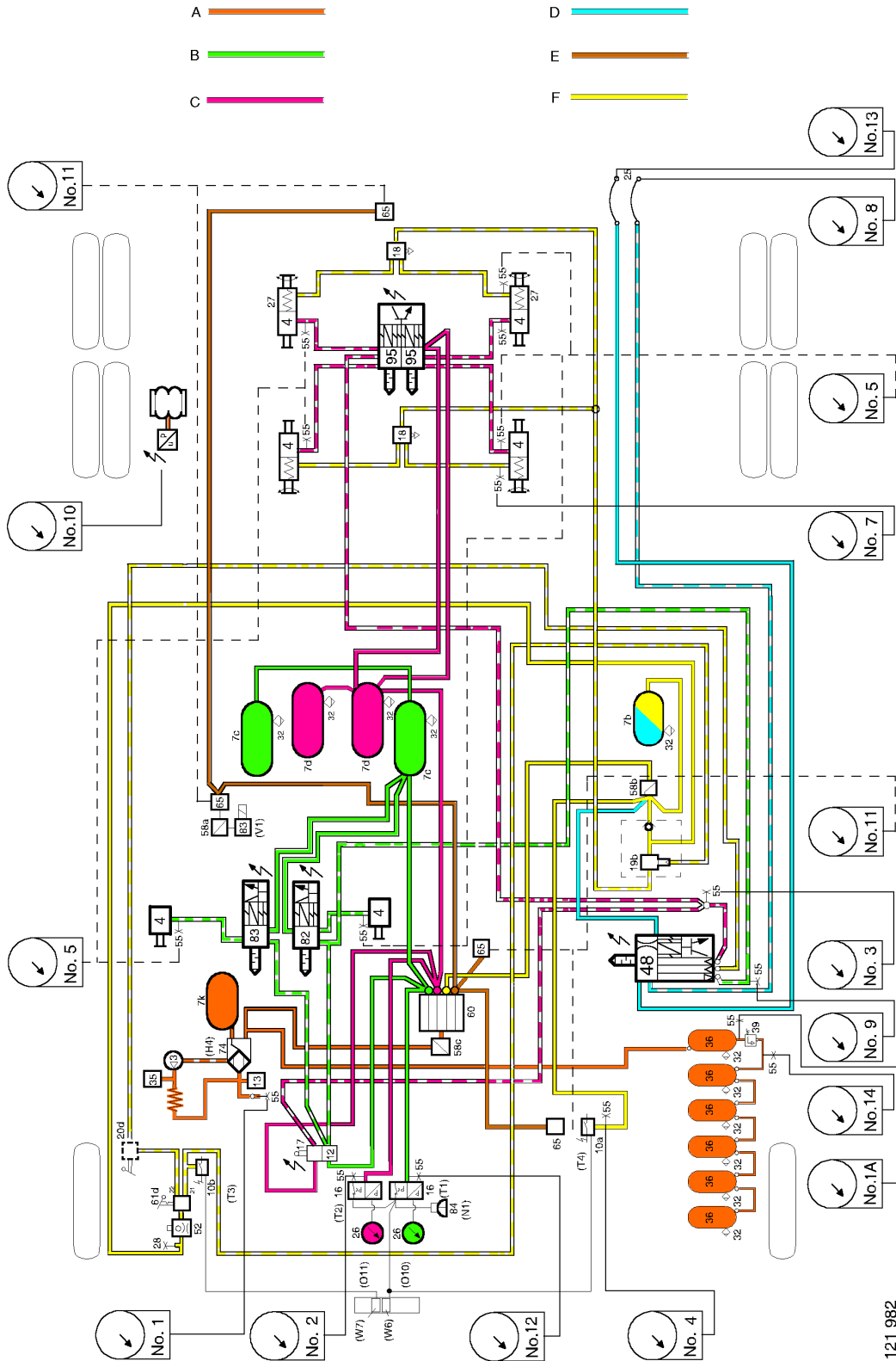

- A Supply circuit
- B Front circuit
- C Rear circuit
- D Trailer brake circuit
- E Accessory circuit
- F Parking brake circuit

121 982

Socket No.	Circuit of feature to be tested	Location
1	Charging with workshop air	In left-hand step
1A	Measuring supply circuit pressure (on vehicles with 12.2 bar system) Must not be used for charging with workshop air	On the air suspension air tank, in front of the overflow valve
2	Rear circuit, supply pressure	Adjacent to service brake valve
3	Rear circuit, service pressure, backup pressure	In centre valve assembly, bottom connection (R)
4	Parking and trailer brake circuit supply pressure	Adjacent to service brake valve
5	Brake pressure from control module	On each brake chamber
7	Parking brake, control pressure	On the rear spring brake chambers
8	Trailer brake, service pressure	For test connections connected to trailer brake coupling, see In-house manufactured tools
9	Front circuit, service pressure, backup pressure	In centre valve assembly, top connection (F)
10	Rear circuit load-sensing valve, air spring pressure	Beside solenoid valve block for air suspension
11	Four-circuit protection valve, accessory circuit	One of the outputs on coupling 65, select one of the couplings. Note: Fit a test connection on the appropriate coupling.
12	Front circuit, supply pressure	Adjacent to service brake valve
13	Trailer brake, supply pressure	For test connections connected to trailer brake coupling, see In-house manufactured tools
14	Supply circuit, check valve in overflow valve 39	On the air suspension air tank, behind the overflow valve

Checking pressure gauges

IMPORTANT! The pressure gauges must be used in a suspended position, in the same way as when they are set to zero.

Note: Always check that the cables and connections in the circuits are airtight.

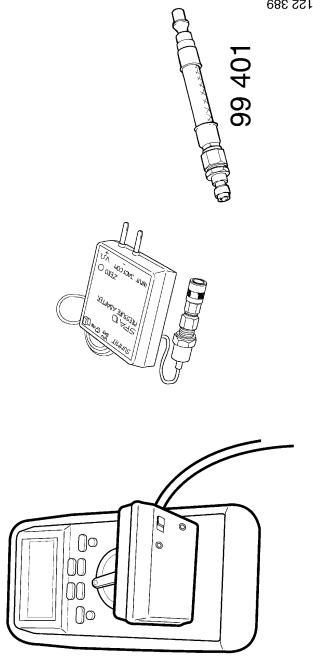

Multimeter with converter from measuring set 99 362 and adapter 99 401

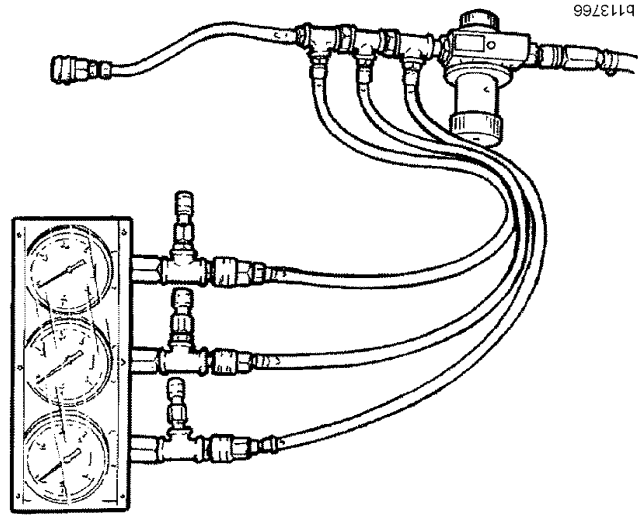

Connection diagram for checking 2.5 bar pressure gauges

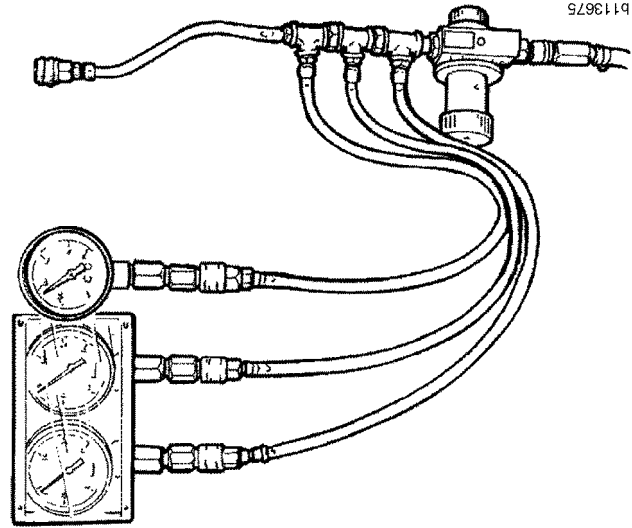

Connection diagram for checking 15 bar pressure gauges

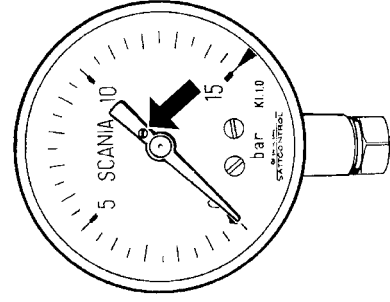

Adjusting screw on pressure gauges

Equipment/Pressure gauges

2.5 bar 15 bar

3 3

Test measures	Pressure gauge		Cause of fault / action
	2.5 bar	15 bar	
2.5 bar pressure gauges <ul style="list-style-type: none"> - Connect adapter 99 401 to the pressure reduction valve. - Connect the adapter to the converter. Then connect the converter to multimeter 588 093. - Set the multimeter to direct current voltage and turn on the converter. - Zero the multimeter by turning the converter set screw marked zero. - Zero the indicators on the pressure gauges. - Turn the knob anticlockwise until the relief valve is closed. - Connect the air hose from the workshop air system to the relief valve. - Connect the three hoses from the relief valve to each pressure gauge. - Turn the relief valve knob clockwise until the pressure gauges and the multimeter show approximately 1 bar. The voltage reading shown in the multimeter window corresponds to the pressure in bar. - Check that the pressure gauges show the same. 			<p>Check that the pressure gauge value agrees with the value on the multimeter with a tolerance of +/- 0.025 bar/V. If it does not, return the pressure gauge for calibration.</p>
	1.0		

Test measures	Pressure gauge		Cause of fault / action
	2.5 bar	15 bar	
<ul style="list-style-type: none"> - Raise the air pressure using the relief valve to 1.5 and 2.0 bar and check that the pressure gauges and the multimeter correspond. - Increase air pressure to 2.5 bar, at which point the safety valves should open. 15 bar pressure gauges - Set the displays to zero. - Connect an air hose to each pressure gauge. - Turn the knob clockwise until the pressure gauges show 5 bar. - Check that the pressure gauges correspond. - Raise the air pressure to 6 and 7 bar and check that the pressure gauges correspond. 	2.5	<p>The opening pressure is adjusted by turning the adjusting sleeves on the safety valves.</p> <p>5.0</p> <p>Check that the pressure gauge value agrees with the value on the multimeter with a tolerance of +/- 0.1 bar/V. If it does not, return the pressure gauge for calibration.</p>	

1. Testing operating pressure, seal integrity and check valve in overflow valve (39)

Note the reading in the report accompanying this booklet.

Equipment/Pressure gauges

2.5 bar	15 bar
--	3

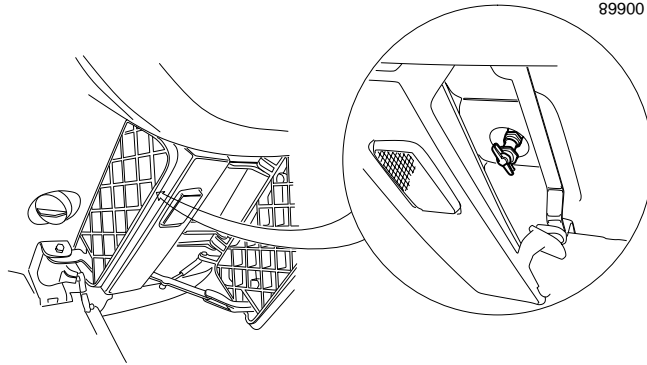

Test connection 1

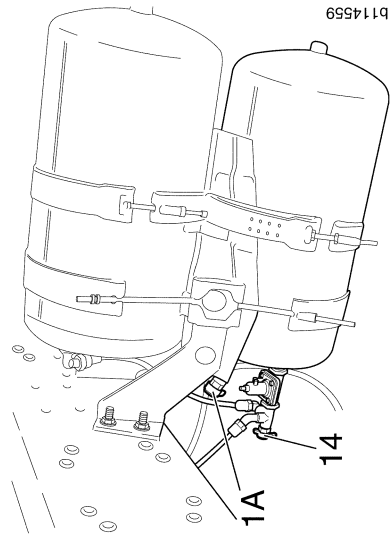

Test connections 1A and 14

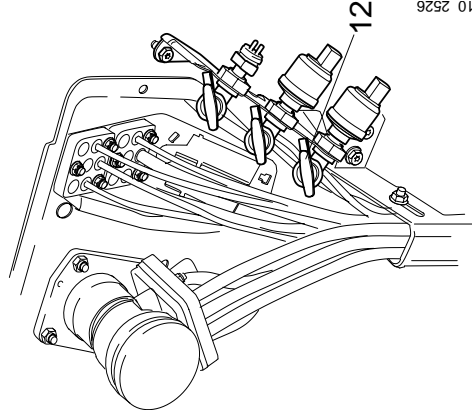

Test connection 12

Test measure	Test connection (bar)		Cause of fault / action
	12	1A	
<p>Vehicles with load handling tanks</p> <ul style="list-style-type: none"> - Connect 15 bar pressure gauge to test connections 12, 1 and 1A. - Start the engine and charge the system. - Check the relief pressure at test connection 1A by noting when the pressure at test connection 1 drops. Check the pressure limiting valve (58c) at test connection 12. - Decrease the system pressure by draining the first load handling tank. - Note the pressure at test connection 1A when the compressor starts to charge. The compressor starts charging when the pressure rises at test connection 1. Calculate the pressure difference to obtain the operating range of the compressor. <p>Checking the check valve in the overflow valve (39)</p> <ul style="list-style-type: none"> - Move the pressure gauge from test connection 1A to test connection 14. - Drain the first load handling tank. - The pressure at test connection 14 must not drop. <p>Vehicles without load handling tanks</p> <ul style="list-style-type: none"> - Connect 15 bar pressure gauges to test connections 12 and 1. - Start the engine and charge the system. - Check the relief pressure at test connection 12 by noting when the pressure at test connection 1 drops. - Decrease the system pressure by repeatedly depressing the brake pedal. - Note the pressure at test connection 12 when the compressor starts to charge. The compressor starts charging when the pressure rises at test connection 1. Calculate the pressure difference to obtain the operating range of the compressor. 	<p>9.1 - 9.5</p> <p>12.0 - 12.4</p> <p>10.4 - 11.5</p>	<p>9.1 - 9.5</p> <p>7.9 - 8.9</p>	<p>If the pressure at test connection 14 drops, the overflow valve (39) must be replaced.</p>

Test measure	Test connection (bar)		Cause of fault / action
<p>Seal integrity</p> <ul style="list-style-type: none"> - Fill the system to operating pressure. - Fully depress the brake pedal. Wait 30 seconds. Read and record the pressure. - Keep the pedal depressed a further 1 minute. - Read and record the pressure. 	12	1A	<p>If pressure drop is greater, the leak must be repaired before continuing the test.</p>

2. Checking anti-freeze unit



WARNING!

Release the air from the system before removing the desiccant container

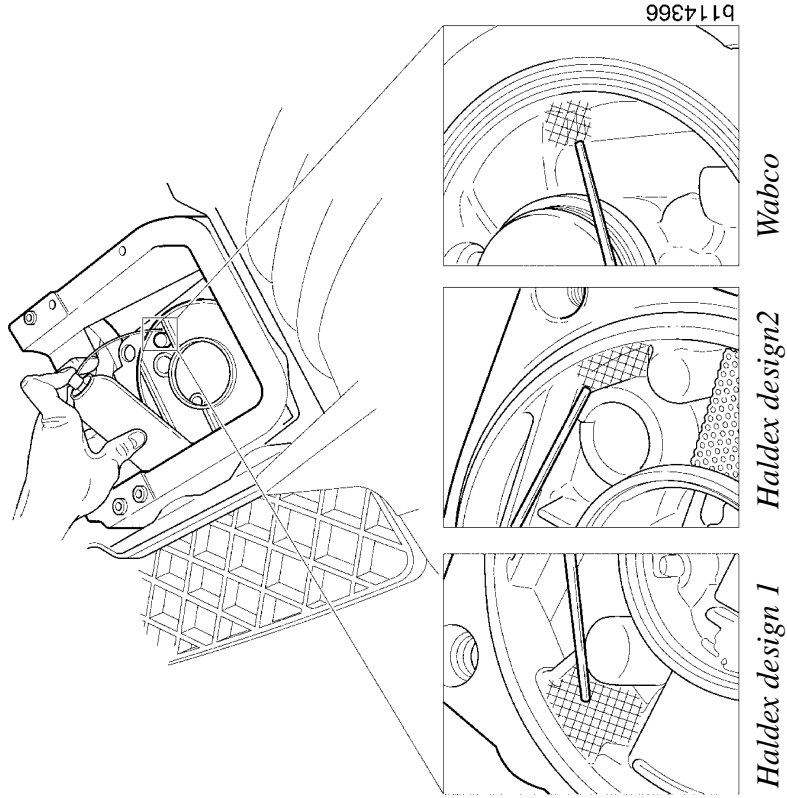

Air dryer

Haldex and Wabco

Resistance

5.0 -7.5 ohm at temp < + 7 °C

Test measure	Cause of fault / action
<p>Air dryer</p> <ul style="list-style-type: none"> - Note the completed function check in the brake test report. - Check that the drain valve in the bottom of the dryer does not leak when the compressor is charging. <p>Checking the heater element</p> <ul style="list-style-type: none"> - Start the engine and check whether there is a supply voltage in the connector to the air dryer heater element, 24 - 28.8 volts <p>Air dryer temperature below +7°</p> <ul style="list-style-type: none"> - Start the engine and feel to see if the underside of the dryer heats up within a couple of minutes. The temperature should rise to 20-30 °C, which is the switch-off temperature of the thermostat. <p>Air dryer temperature above +7°</p> <ul style="list-style-type: none"> - Remove the P2/H contact in the central electric unit. - Connect a multimeter set for measuring resistance between ground and the green wire marked 61C on pin 12 in the H contact. - Place the multimeter on top of the instrument panel with its display window facing the windscreen. - Tilt the cab or drop down the bonnet. Remove the cover over the air dryer. - Remove the desiccant container. - Cool down the air dryer as illustrated using e.g. cooling spray until it is below +7°C, which is the opening temperature of the thermostat. Spray at intervals to allow time for the cold to propagate through the material. - Measure the resistance at the contact. 	<p>When the compressor is relieving load, the drain valve should open. The air in the dryer should then be evacuated. Evacuation takes up to 40 seconds.</p> <p>Rectify the air dryer if it is not operating in accordance with the test stages, see main group 10 in the Service Manual, Supply circuit components.</p>

3a. Testing four-circuit protection valve type 1 and type 3

Equipment/Pressure gauges

2.5 bar	15 bar
--	3

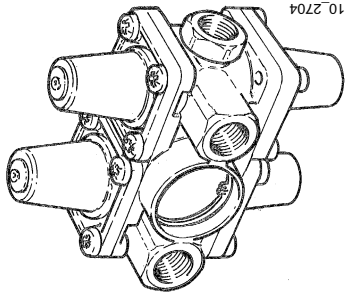

10_2704

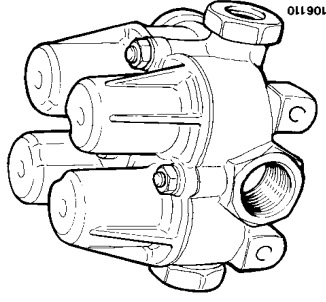

106110

Type 1 Wabco

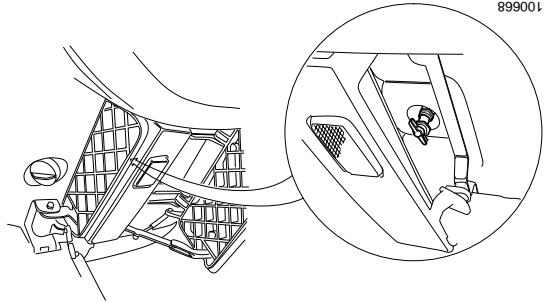

100668

Test connection 1

Type 3 Knorr

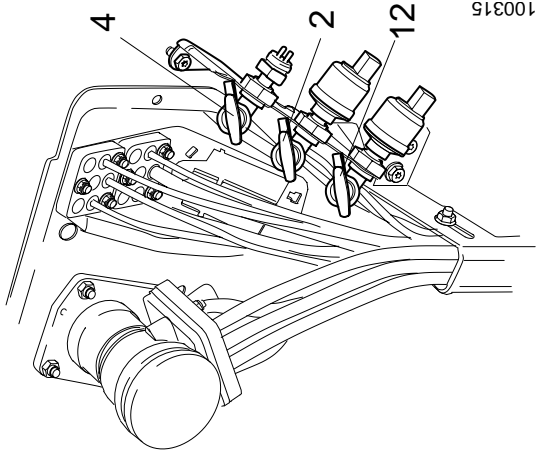

100315

Test connections 2, 4 and 12

Test measure	Test connection (bar)					Cause of fault / action
	1	2	4	11	12	
<p>Checking the opening pressure</p> <p>The only circuit that needs to be tested is the parking brake circuit, since legal provisions state that it must not be charged before the service brake circuits have reached emergency brake pressure.</p> <ul style="list-style-type: none"> - Evacuate the system. - Connect 15 bar pressure gauge to test connections 2, 4 and 12. - Charge the system and check that the pressure in the front and rear circuits is at least 5 bar before the parking brake circuit clearly opens. <p>Checking closing pressure</p> <p>Front circuit and rear circuit</p> <ul style="list-style-type: none"> - Charge the system to at least 7.5 bar and make sure the compressor is in charging mode. - Connect a 15 bar pressure gauge to the rear circuit test connection 2, the front circuit test connection 12 and test connection, filler nipple 1. - Drain the accessory circuit. - Check that the pressure in the rear circuit and the front circuit is not below 4 bar and the test connection, filler nipple drops to zero. 		> 5.0			> 5.0	If the value is incorrect, replace the valve.
	0.0	> 4.0			> 4.0	If the value is incorrect, replace the valve.

Test measure	Test connection (bar)					Cause of fault / action
	1	2	4	11	12	
<p>Parking brake circuit and accessory circuit</p> <ul style="list-style-type: none"> - Charge the system to at least 7.5 bar and make sure the compressor is in charging mode. - Connect a 15 bar pressure gauge to the parking brake circuit test connection 4, the accessory circuit test connection 11 and test connection, filler nipple 1. - Drain the rear circuit by fitting a pressurising hose to test connection 2. - Check that the pressure in the parking brake circuit and the accessory circuit is not below 4 bar, and the test connection filler nipple drops to zero. The pressure in the parking brake circuit will continue to drop because it does not have a check valve. 	0.0		> 4.0	> 4.0		If the value is incorrect, replace the valve.

3b. Testing four-circuit protection valve type 2, 4 and 5

Equipment/Pressure gauges

2.5 bar	15 bar
--	3

Types 2, 4 and 5 are similar. The difference between them is that there is a bypass function in types 4 and 5 that drains the parking brake circuit if the rear circuit is empty. Type 5 has increased opening pressure and is found on T-vehicles.

Type 4 is present as from chassis number:

- Scania Södertälje 1 261 040
- Scania Netherlands
- Scania Angers

Type 5 is present from 2001-09, T-vehicles.

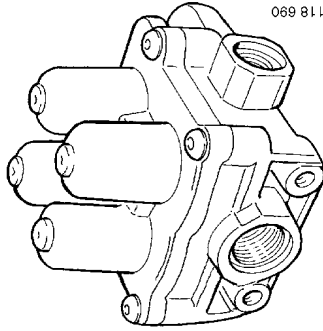

Types 2, 4, 5 Wabco

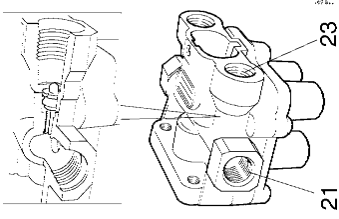

Types 4 and 5 Wabco

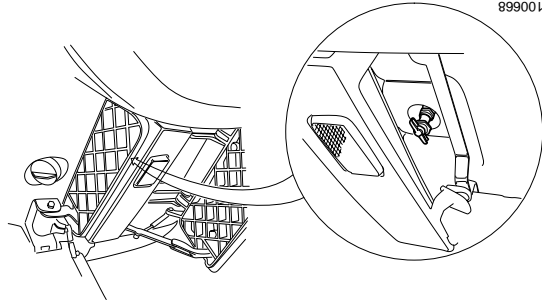

Test connection 1

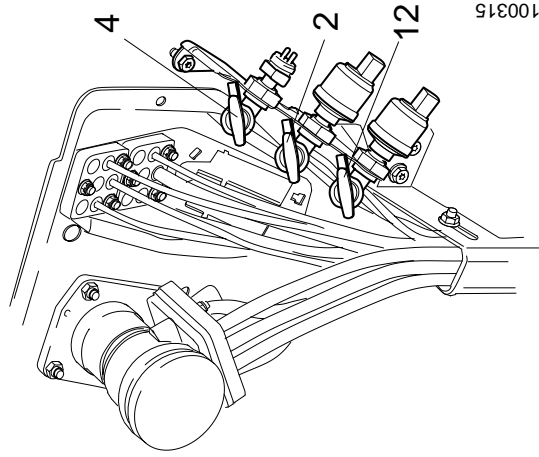

Test connections 2, 4 and 12

Test measure	Test connection (bar)					Cause of fault / action
	1	2	4	11	12	
<p>Checking the opening pressure</p> <p>The only circuit that needs to be tested is the parking brake circuit, since legal provisions state that it must not be charged before the service brake circuits have reached emergency brake pressure.</p> <ul style="list-style-type: none"> - Evacuate the system. - Connect 15 bar pressure gauges to test connections 2, 4 and 12. - Charge the system and check that the pressure in the front and rear circuits is at least 5 bar before the parking brake circuit clearly opens. <p>Checking closing pressure</p> <p>Front circuit</p> <ul style="list-style-type: none"> - Connect a 15 bar pressure gauge to the test connection, filler nipple 1. - Charge the system to at least 8.5 bar and make sure the compressor is in charging mode. Drain the front circuit and read off the pressure gauge. <p>Rear circuit</p> <ul style="list-style-type: none"> - Charge the system to at least 8.5 bar and make sure the compressor is in charging mode. Drain the rear circuit and read off the pressure gauge. <p>Parking brake circuit</p> <ul style="list-style-type: none"> - Charge the system to at least 8.5 bar and make sure the compressor is in charging mode. Drain the parking brake circuit and read off the pressure gauge. <p>Accessory circuit</p> <ul style="list-style-type: none"> - Charge the system to at least 8.5 bar and make sure the compressor is in charging mode. Drain the accessory circuit and read off the pressure gauge. 		> 5.0				<p>If the value is incorrect, replace the valve.</p> <p>If the value is incorrect, replace the valve.</p> <p>If the value is incorrect, replace the valve.</p> <p>If the value is incorrect, replace the valve.</p> <p>If the value is incorrect, replace the valve.</p>
	> 4.0					
	> 4.0					
	> 4.0					
	> 4.0					

Test measure	Test connection (bar)					Cause of fault / action
	1	2	4	11	12	
<p>Bypass function, types 4 and 5 only</p> <ul style="list-style-type: none"> - Apply the parking brake. - Charge system to relief pressure. - Connect 15 bar pressure gauges to parking brake circuit test connection 4 and rear circuit test connection 2. - Drain the rear circuit. - Check that the pressure in the parking brake circuit does not exceed the specified value and that the rear circuit drops to 0. 		0.0	< 5.0			If the value is incorrect, replace the valve.

4. Testing parking brake / emergency brake and function of pressure limiting valve (58b) and relay check valve

Equipment/Pressure gauges

2.5 bar	15 bar
--	3

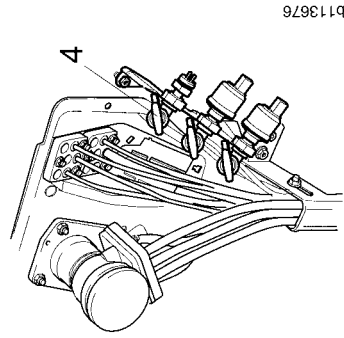

b113676

Test connection 4

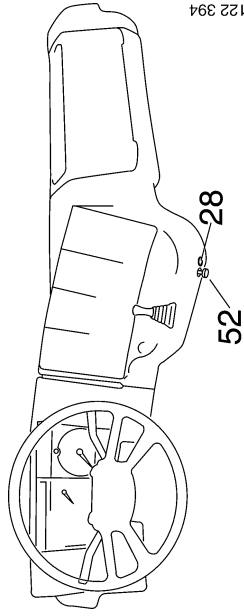

122 394

Filler nipple 28
Interlock valve 52

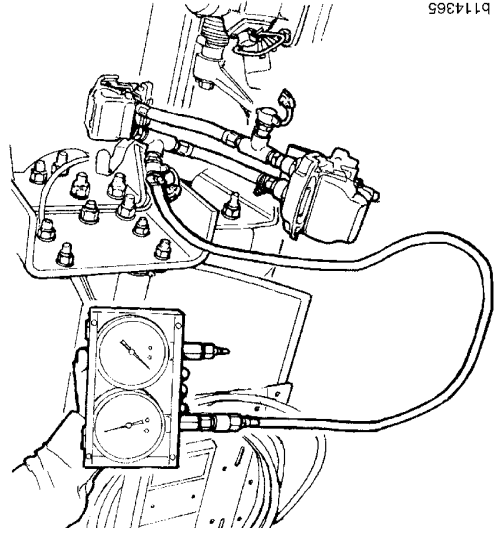

b114365

Test connection 8

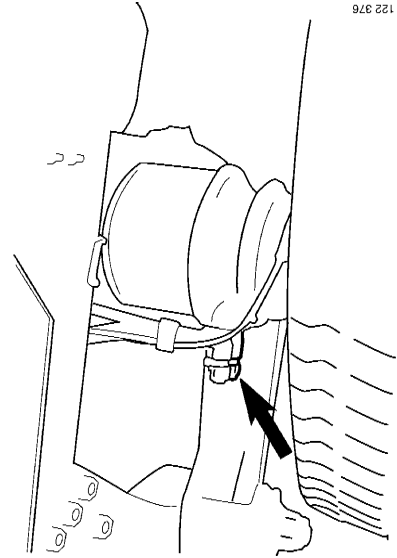

122 376

Test connection 7

Test measure	Test connection (bar)			Cause of fault / action
	7	8	4	
<p>Pressure limiting valve (58B)</p> <ul style="list-style-type: none"> - Charge the system. Close the air supply. - Read the pressure gauge at test connection 4. <p>Parking brake, emergency brake</p> <ul style="list-style-type: none"> - Place chocks in front of and behind at least two wheels. - Connect 15 bar pressure gauges to test connections 4, 7 and 8. <p>If the vehicle does not have a trailer relay valve (57) or trailer module (V48), only one pressure gauge should be connected to test connection 7.</p> <ul style="list-style-type: none"> - Charge system to relief pressure. Close the air supply. <p>1 Parking brake in drive position. (The values in brackets only apply to vehicles with US-adapted brake systems.)</p> <p>2 Lever to full emergency brake position.</p> <p>3 Lever in parking position. (Valve without check position) Lever in parking position. (Valve <u>with</u> check position)</p> <p>4 Lever to test position.</p>	<p>7.4 - 8.2 (6.7 - 7.5)</p> <p>0.0</p> <p>0.0</p> <p>0.0</p> <p>0.0</p>	<p>0.0</p> <p>6.6 - 7.6 (6.0 - 7.0)</p> <p>0.0</p> <p>6.6 - 7.6</p> <p>0.0</p>	<p>7.7 - 8.3 (7.0 - 7.6)</p>	<p>Incorrectly adjusted pressure limiting valve.</p> <p>Test connection 7: Incorrectly adjusted pressure limiting valve (58b) or faulty parking brake valve (61d).</p> <p>Test connection 8: Incorrectly adjusted pressure limiting valve (58b) or faulty parking brake valve (61d) or trailer relay valve (57).</p>

Test measure	Test connection (bar)			Cause of fault / action
	7	8	4	
<p>Check valve in relay valve for parking brake</p> <ul style="list-style-type: none"> - Apply the parking brake - Place wheel chocks on one wheel. - Evacuate air from the parking brake circuit via test connection 4. - Put the parking brake in drive position. - Connect 15 bar pressure gauges to test connections 4 and 7. - Press in the interlock valve 52 if fitted and charge the parking brake circuit to 6-8 bar via filler nipple 28. - Read the pressure gauge at test connection 7. The pressure must not drop more than 1 bar in 1 minute. 	6.0 - 8.0		0.0	<p>Pressure rise at test connection 4 indicates defective check valve in relay valve for parking brake.</p> <p>A large pressure drop at test connection 7 indicates a leak in the control circuit or brake chambers.</p>

5. Fault codes

- Connect Scania Diagnos.
- Check whether the vehicle has any fault codes. Rectify active faults immediately.
- Fault codes can arise due to the vehicle being incorrectly configured.

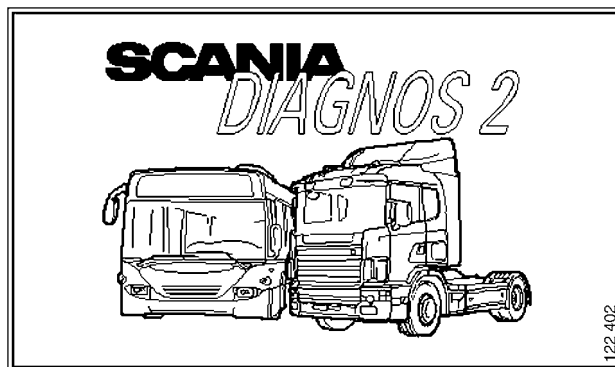

6. Configuration

- Check the vehicle configuration.

Change the configuration using Scania Programmer if it is not correct.

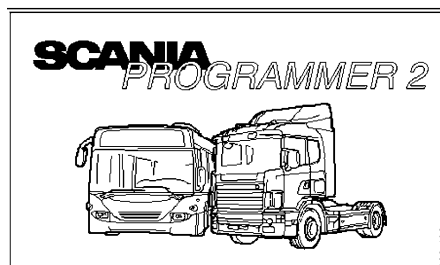

SD2 - [Truck 4 series - EBS Knorr 2.2 - Configuration]

File Window ?

- 1 - Wheel configuration: 6x2
- 2 - Tag axle: ASA1000
 - Number of double control modules
- EDC: With
- TC: With
- Retarder: With
- 3 - Trailer control module: Without / With
- 4 - Wheelbase (dm): 39
- 5 - Rolling radius (mm): 522
- 6 - Rear axle gear ratio: 3.08
- 7 - Weight class: High
- 8 - Service brake valve characteristics: 1700702082002162 / Comfort Value
 - Chassis adaptation: Truck
 - Signature: KFL



Close

Help

121 676

SD2 - [Truck 4 series - EBS Bosch - Configuration]

File Window ?

Configuration:
 Data set number
 Wheel configuration
 TC Yes

Close

Help

122 670

SD2 - [Truck 4 series - EBS Bosch 2.1 - Configuration]

File Window ?

- Wheel configuration: 6x2
- Tag axle: ASA700
- Chassis adaptation: Truck
- TC: With
- Wheelbase (dm): 35
- Rolling radius (mm): 525
- Programming date:
- Signature

Close

Help

122 678

cardiagn.com

The following pages contain a description of the Configuration window. Note that different EBS systems use different configuration windows.

1 *Wheel configuration: Specified on the type plate on the right-hand side of the cab.*

2 *Tag axle:*

ASA 700 has single-mounted wheels.

ASA 1000 has twin-mounted wheels.

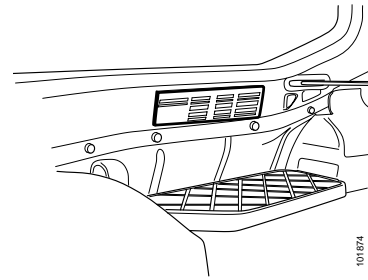

3 *Trailer control module: The trailer control module is located in the centre valve assembly. Compared with a conventional trailer brake relay valves, the trailer control module has an electric connection. The electric connection is located in towards the frame.*

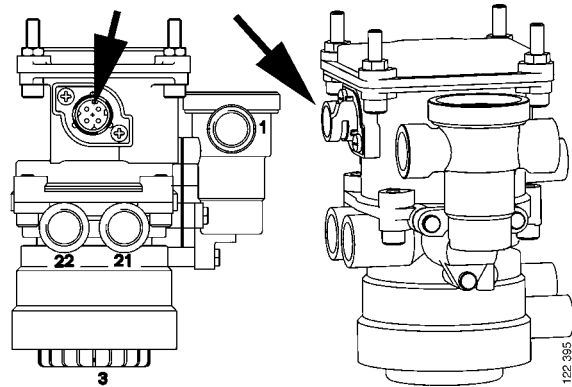

4 *Axle distance: Axle distance is the distance between the centre of the 1st front axle and the centre of the driving axle given in decimetres.*

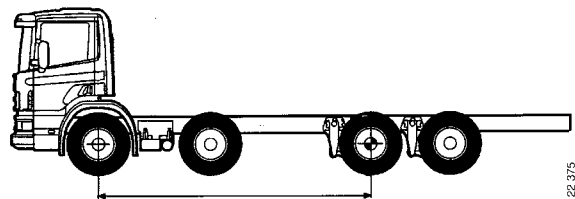

5 *Rolling radius: The radius of the driving wheels calculated using the tyre dimensions.*

Dimension	Radius, mm	Dimension	Radius, mm
10.00R20	511	295/60R22.5	447
11.00R20	525	295/80R22.5	507
11R22.5	510	305/60R22.5	452
12.00R20	545	305/70R22.5	485
12.00R24	595	315/60R22.5	458
12R22.5	526	315/70R22.5	492
13R22.5	546	315/80R22.5	522
14.00R20	601	385/65R22.5	517
275/70R22.5	465	425/65R22.5	542
275/80R22.5	491		

7 *Weight class:*

No. of axles	Gross vehicle weight	Weight class
2	max. 16000 kg.	Low: New Zealand, Australia
3	max. 24000 kg.	
4	max. 30000 kg.	
2	above 16000 kg.	High: Other markets
3	above 24000 kg.	
4	above 30000 kg.	

6 *Rear axle ratio: This value is included on vehicles with EBS2.2 and TCM. The axle gear ratio is stamped on a plate on the rear axle.*

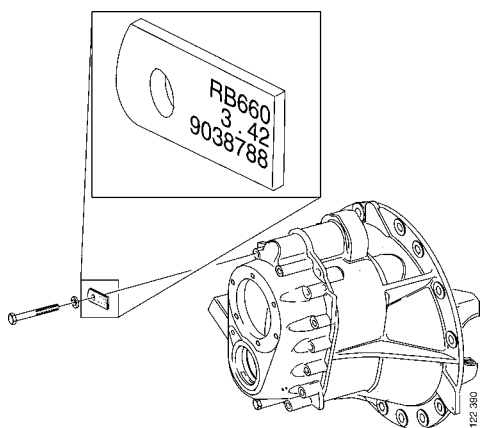

8 *Service brake valve characteristics are specified on a label hanging from the valve as well as on the valve itself. A comfort value is given in Scania Diagnos for vehicles with TCM (V48).*

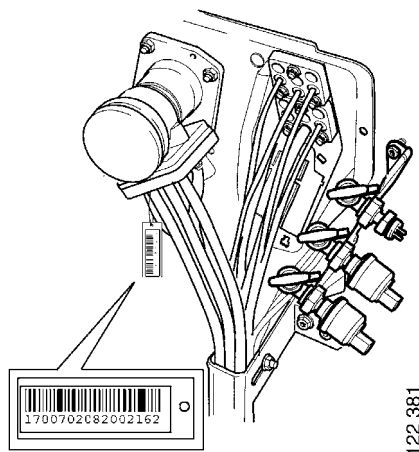

7. Lining wear sensor

IMPORTANT! The lining wear sensor measures the total thickness of the brake pad - brake disc - brake pad. This means that the sensor will indicate excessive lining wear if new brake pads are being used with a worn brake disc.

Brake pad wear

- Check the brake pad wear using Scania Diagnos and note it on the report.

Check the lining wear sensors if abnormal values are indicated, e.g. uneven wear.

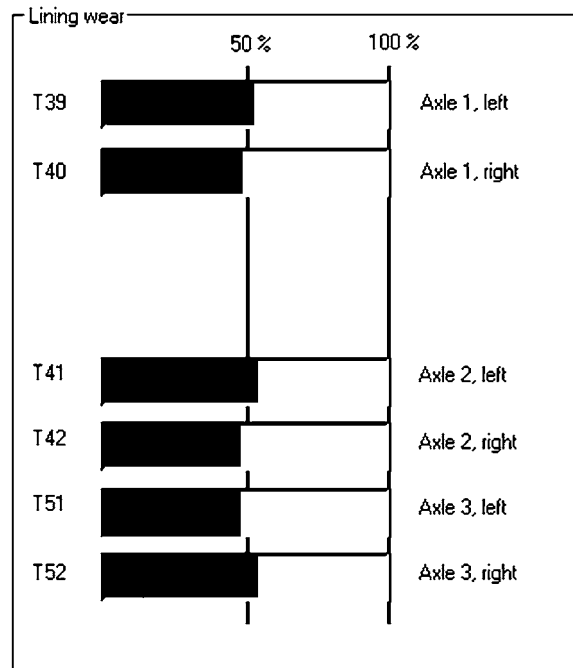

Checking lining wear sensors

Note: Fault codes can be set if the contacts are pulled apart when the starter key is in drive position. Therefore, always put the starter key in locking position, 15V supply off

- Check any cables leading to the brake pads on the brake caliper in question. Not all vehicles or brake pads are fitted with these cables.
- Check that the cable between the brake caliper and the control module is intact.
- Turn the adjuster screw on the brake caliper to withdraw the brake pad from the brake disc.
- Put the starter key in drive position, 15V supply, and connect Scania Diagnos. Take a reading of the brake pad wear.
- Depress and release the brake pedal. Then take a reading of the brake pad wear from Scania Diagnos. The value is displayed with a certain delay.

If the lining wear sensor is intact, the value after repeatedly depressing and releasing the brake pedal will finally drop to approximately the value read earlier. It will be difficult to obtain the same value as earlier due to the internal tolerances in the lining wear sensor.

- A faulty lining wear sensor will give an implausible value in relation to the actual wear or a value that does not change during the entire check.
- Renew the brake caliper if the fault can be traced to the lining wear sensor.

IMPORTANT! Restore the condition of the vehicle and readjust the brakes manually to their basic setting using the adjusting screw. Refer to *Workshop Manual, group 10, Disc brakes*.

8. Checking warning lamps and sensors

Equipment/Pressure gauges

2.5 bar	15 bar
1	

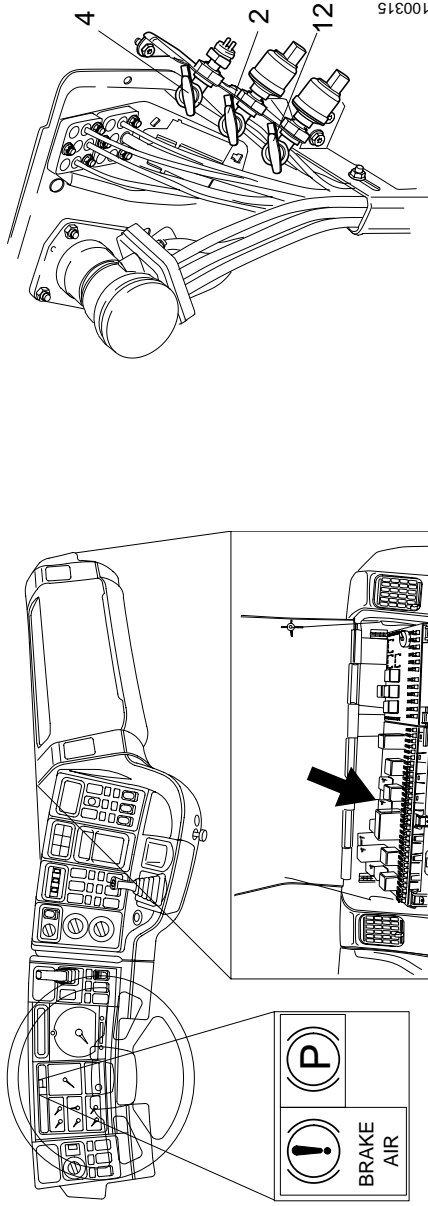

Test connections 2, 4 and 12

Test measures	Test connection (bar)			Cause of fault / action
	12	2	4	
<p>Front circuit</p> <ul style="list-style-type: none"> - Charge the system with air. - Check that the displays in the cab show full system pressure. - Connect the pressure gauge to test connection 12. - Disconnect the sensors from test connections 2 and 4. - Drain the front circuit tank (7c) until the warning lamp comes on and the buzzer sounds. Check also that the signal can be read in Scania Diagnostics - Check that the display in the cab shows the correct pressure. 	12	2	4	Fault in the sensor, lamp or buzzer.

Test measures	Test connection (bar)			Cause of fault / action
	12	2	4	
<p>Rear circuit</p> <ul style="list-style-type: none"> - Charge the system with air. - Connect the pressure gauge to test connection 2. - Disconnect the sensors from test connections 4 and 12. - Drain the rear circuit tank (7d) until the warning lamp comes on and the buzzer sounds. Check also that the signal can be read in Scania Diagnos - Check that the display in the cab shows the correct pressure. <p>Parking brake circuit (feed)</p> <ul style="list-style-type: none"> - Charge the system with air. - Connect the pressure gauge to test connection 4. - Disconnect the sensors from test connections 2 and 12. - Drain the parking tank (7b) until the warning lamp comes on and the buzzer sounds. Check also that the signal can be read in Scania Diagnos <p>Parking brake circuit (control)</p> <ul style="list-style-type: none"> - Charge the system. - Apply the parking brake. - Check that the parking brake lamp comes on. Check also that the signal can be read in Scania Diagnos 		4.5 - 5.5		Fault in the sensor, lamp or buzzer.
			4.5 - 5.5	Fault in the sensor, lamp or buzzer.
				Fault in the sensor or lamp.

9. Pedal position sensor, D39

The sensor comprises two potentiometers with inverted signal levels, one high and the other low.

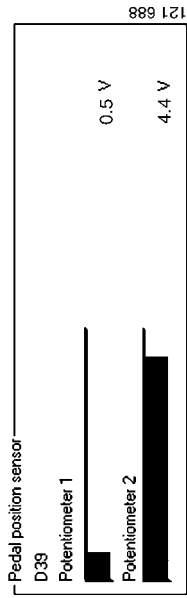

Diagnostic window for pedal position sensor with brake pedal fully released

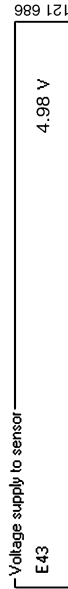

Diagnostic window for voltage supply to pedal position sensor, D39.

Test measures	Limit values	Cause of fault / action
<p>Voltage supply</p> <ul style="list-style-type: none"> - Check the voltage supply to the pedal position sensor from the EBS control unit, E43. <p>Pedal position sensor</p> <ul style="list-style-type: none"> - Check that the bars change relatively in a linear fashion while carefully depressing and releasing the brake pedal. 	<p>E43</p> <p>EBS 2.0: 4.47 - 5.41 V EBS 2.1: 4.80 -5.20 V EBS 2.2: 4.55 -5.45 V</p> <p>D 39</p> <p>Potentiometer 1: 0.3 - 4.5 V Potentiometer 2: 4.6 -0.3 V</p> <p>Limits for fully released brake pedal, 0-position: Potentiometer 1: 0.3 -0.5 V Potentiometer 2: 4.4 -4.6 V</p>	<p>Troubleshoot the circuit if the values are incorrect. Refer to components and wiring diagram in Scania Diagnos</p>

10. Checking load sensing pressure sensor, T46

Equipment/Pressure gauges

2.5 bar	15 bar
1	--

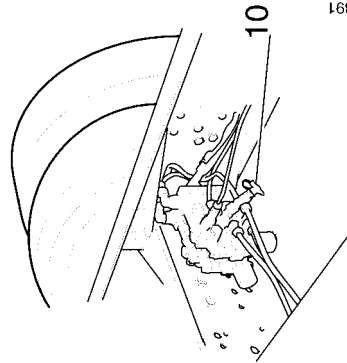

122 391

Test connection 10



121 687

T46, Scania Diagnos EBS 2.2

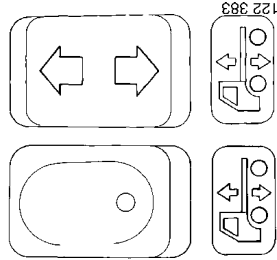

122 383

Switch, mechanical air suspension

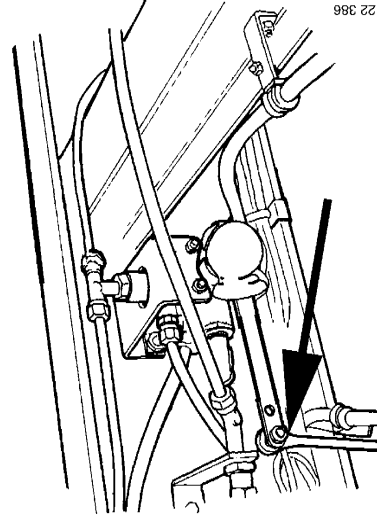

122 386

Link arm to level valve, mechanical air suspension

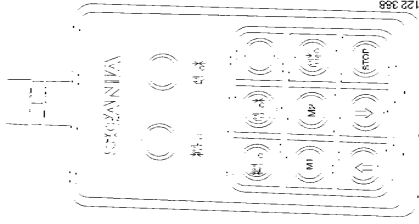

122 388

Operation unit, ELC

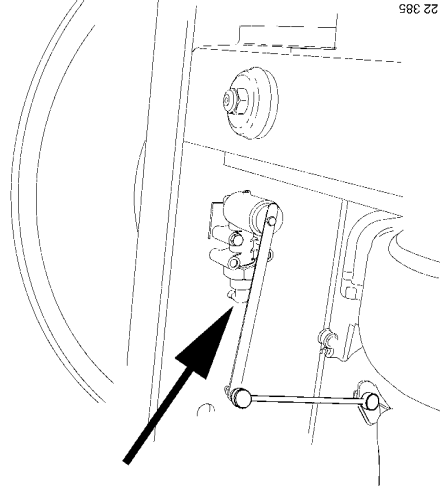

122 385

Switch for T73 level sensor, electronic air suspension - ELC

IMPORTANT! The compressed air system must be pressurised over 9 bar.

Test measures	Test connection (bar) 10	Scania Diagnos T46	Cause of fault / action
<p>1a. Laden vehicle, all air suspension</p> <ul style="list-style-type: none"> - Connect Scania Diagnos and go to the window for <i>Load sensing pressure sensor T46</i>. - Connect a 2.5 bar pressure gauge to test connection 10. - Use the air suspension operation unit or the air suspension switches on the instrument panel. Fill the air bellows to a pressure of 2 bar according to Scania Diagnos, T46. <i>If a pressure of 2 bar cannot be attained, use method 1b or 1c instead.</i> - Compare Scania Diagnos/pressure gauge. Make a note in the report. - Then discharge the air suspension to a pressure of 0 bar using the operation unit or the switches on the instrument panel. - Make a note in the report. <p>1b. Unladen vehicle with ELC</p> <ul style="list-style-type: none"> - Unplug the air suspension level sensor, T73. - Connect a 2.5 bar pressure gauge to test connection 10. - Connect Scania Diagnos and go to the window for <i>Load sensing pressure sensor T46</i>. - Use the vehicle's air suspension operation unit to fill the air bellows to a pressure of 2 bar according to Scania Diagnos, T46. - Compare Scania Diagnos/pressure gauge. Make a note in the report. 	<p>1.5 - 2.5</p> <p>-0.5 - 0.5</p> <p>1.5 - 2.5</p>	<p>2.0</p> <p>0.0</p> <p>2.0</p>	<p>Troubleshoot the circuit for the load sensing pressure sensor if the value is incorrect.</p> <p>Troubleshoot the circuit for the load sensing pressure sensor if the value is incorrect.</p> <p>Troubleshoot the circuit for the load sensing pressure sensor if the value is incorrect.</p>

Test measures	Test connection (bar)	Scania Diagnos	Cause of fault / action
<ul style="list-style-type: none"> - Then discharge the air suspension to 0 bar using the operation unit. - Make a note in the report. - Plug in the air suspension level sensor, T73. - Check and clear fault codes that have been set in the ELC system when the air suspension level sensor was unplugged. <p>1c. Unladen vehicle without ELC</p> <ul style="list-style-type: none"> - Detach the link arm to the level valve lever. Lock the lever in drive position so the bellows can be filled with air later. - Connect a 2.5 bar pressure gauge to test connection 10. - Connect Scania Diagnos and go to the window for <i>Load sensing pressure sensor T46</i>. - Fill the air bellows to a pressure of 2 bar according to Scania Diagnos, T46, using the air suspension switch on the instrument panel. - Compare Scania Diagnos/pressure gauge. Make a note in the report. - Then discharge the air suspension to a pressure of 0 bar using the switches on the instrument panel. - Make a note in the report. - Release the level valve lever and reconnect it to the link arm. 	<p>10</p> <p>-0.5 - 0.5</p> <p>1.5 - 2.5</p> <p>-0.5 - 0.5</p>	<p>T46</p> <p>0.0</p> <p>2.0</p> <p>0.0</p>	<p>Troubleshoot the circuit for the load sensing pressure sensor if the value is incorrect.</p> <p>Troubleshoot the circuit for the load sensing pressure sensor if the value is incorrect.</p> <p>Troubleshoot the circuit for the load sensing pressure sensor if the value is incorrect.</p>

11. Communication

- **Signal from exhaust brake to EBS control unit, EBS 2.2**

Check that this signal is active as follows:

Ensure that the switch for the white smoke limiter is set to the off position.

Turn on the switch for the exhaust brake on the instrument panel.

If the vehicle is equipped with retarder, activate the retarder and set it to maximum position, EB.

Symbol A should now be activated in Scania Diagnos.

If the vehicle is equipped with manual exhaust brake with floor-mounted switch, it must now be activated.

If the vehicle is only equipped with automatic exhaust brake via the foot brake pedal, the vehicle must be driven. Drive and brake the vehicle. The exhaust brake should now be activated and the symbol A should be activated in Scania Diagnos.

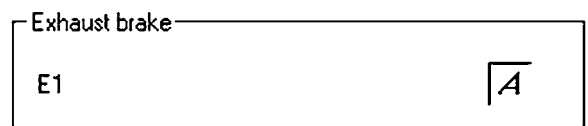
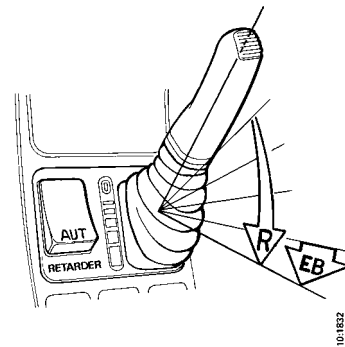
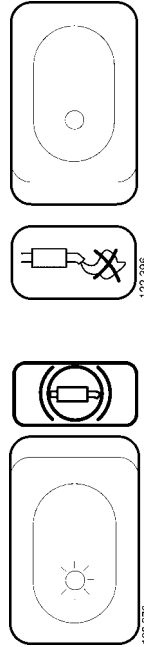

cardiagn.com

- **DBR Signal**

Note: This test stage assumes the air system is fully charged.

The DBR signal is used to instruct the other systems to disengage any auxiliary brakes during ABS modulation.

Vehicles with exhaust brake:

Deactivate the ABS warning lamp

Then activate the exhaust brake according to *Signal from exhaust brake to EBS control unit:*

Activate the DBR signal via Scania Diagnos. The exhaust brake should then clearly disengage.

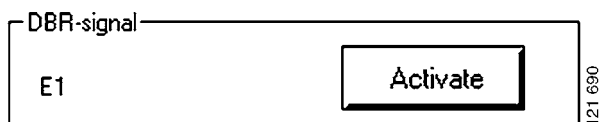

Vehicles without exhaust brake:

Measure the voltage of the DBR signal on junction block C56 /F1.

Activate the DBR signal via Scania Diagnos.

Measure the voltage of the DBR signal on junction block C56.

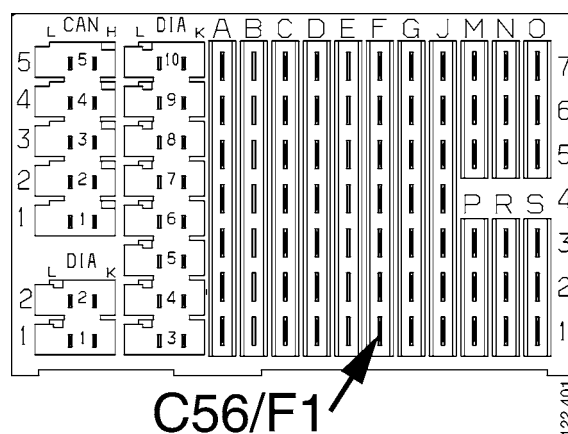

Limit values

DBR Signal

0 - 4.5 V	active
14.5 - 28.8 V	inactive

- **Engine, torque limitation**

Apply the vehicle's parking brake.

Increase engine speed to 1000 rpm with the accelerator pedal and maintain this speed.

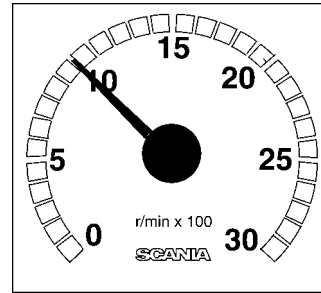

Note: Keep the accelerator pedal in this position during the entire test!

Move the slider control to the left. The engine speed should now drop to idling.

Move the slider control to the right. The engine speed should return to 1000 rpm.

This signal is limited in time. It will stop automatically after five minutes.

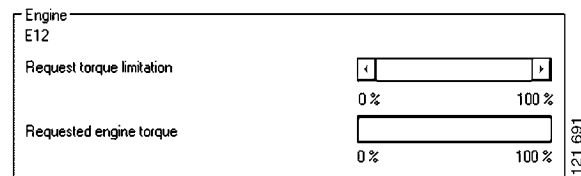

The control unit receives information concerning the requested engine torque from the EDC control unit on EBS version 2.2.

Check the communication between them via the bar in Scania Diagnos. The bar should follow the acceleration.

12. Testing service brake valve

IMPORTANT! This test stage must be carried out with the starter key in locking position. 15V off will then provide backup for EBS.

Note: When measuring **increasing pressure** you may **only depress the brake pedal or keep it still**. If the brake pedal is released when measuring increasing pressure, the test result will be incorrect.

When measuring **falling pressure** you may **only release the brake pedal or keep it still**. If the brake pedal is depressed when measuring falling pressure, the test result will be incorrect.

Equipment/Pressure gauges

2.5 bar	15 bar
2	--

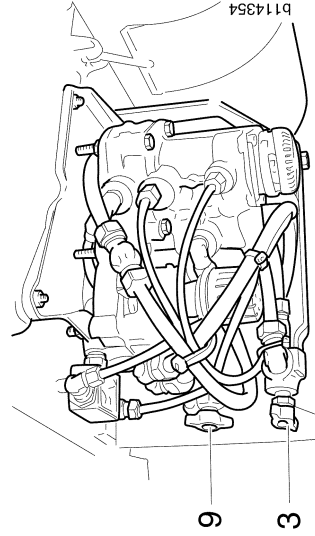

Test connections 3 and 9

Test measure	Test connection (bar)	Cause of fault / action
<ul style="list-style-type: none"> - Connect the pressure gauges to test connections 3 and 9. - Brake in 5 steps according to point 12 on the report. - Measure the difference between the front and rear circuits. Make a note in the report. 	<p style="text-align: center;">3 9</p> <p>See the readings in Testing the EBS brake system, Report, main group 10.</p>	<p>If pressure rises or drops in steps, the service brake valve is sticking and could soon cause problems.</p>

13. Testing initial brake pressure

IMPORTANT! This test stage must be carried out with the starter key in locking position. 15V off will then provide backup for EBS.

Specifications

Brake starting pressure

Maximum initial brake pressure	0.3 - 0.5 bar
--------------------------------	---------------

Equipment/Pressure gauges

2.5 bar	15 bar
---------	--------

1	--
---	----

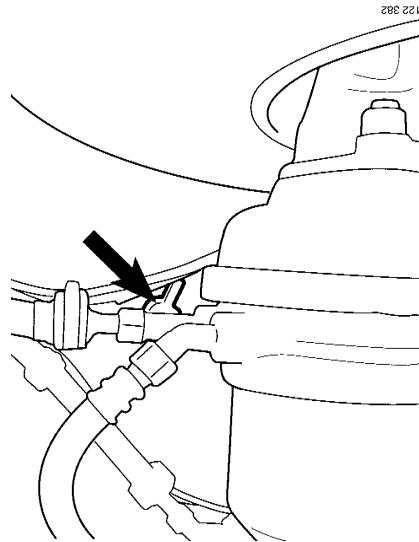

Test connection 5, front axle

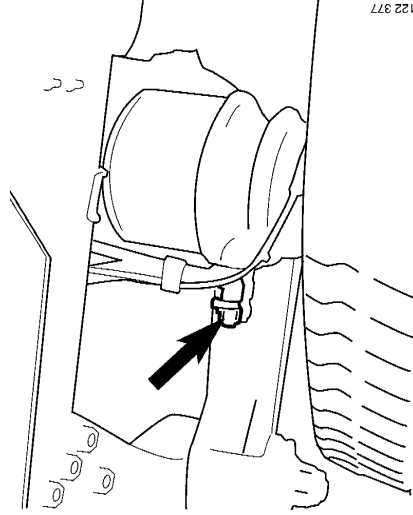

Test connection 5, rear axle

Test measure	Test connection (bar)	Cause of fault / action
<ul style="list-style-type: none"> - Connect the pressure gauge to test connection 5. - Raise the vehicle so that the wheel on which the initial brake pressure is being checked goes free from the ground. - Rotate the wheel. - Ask an assistant to slowly depress the brake pedal. - Read the pressure gauges when the brakes begin to take. - Measure on all wheels. 	5	<p>Note the readings in the brake test report, point 13. The maximum brake starting pressure must lie between 0.3 - 0.5 bar, regardless of cylinder size. Rectify the brakes if the initial pressure or the difference between the axles is higher than specification, as this indicates binding brake calipers. See main group 10 in the Service Manual, Disc Brakes.</p>

14. Checking control modules, voltage supply, regulated pressure and backup pressure

Equipment/Pressure gauges

2.5 bar	15 bar
2	2

A voltage should be displayed for "Supply voltage". Each control module will show its own voltage value.

Use the "Activate" button to pressurise the brake chamber using Scania Diagnos. Set the pressure with the "Set pressure" slider.

Choose "Take reading" to pressurise the control module with the brake pedal. Depressing the brake pedal will send air fully pneumatically to the brake chamber, backup pressure. The regulated pressure is shown at "Pressure sensor".

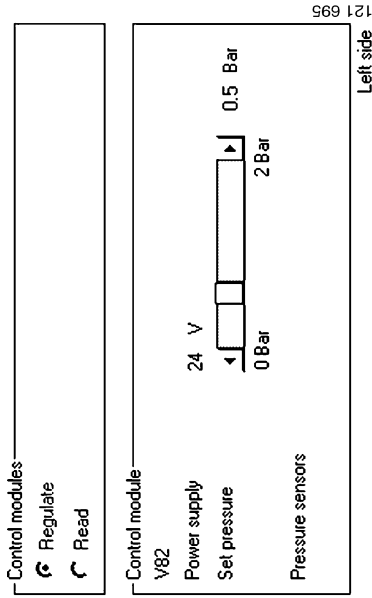

Test connection 5, front axle

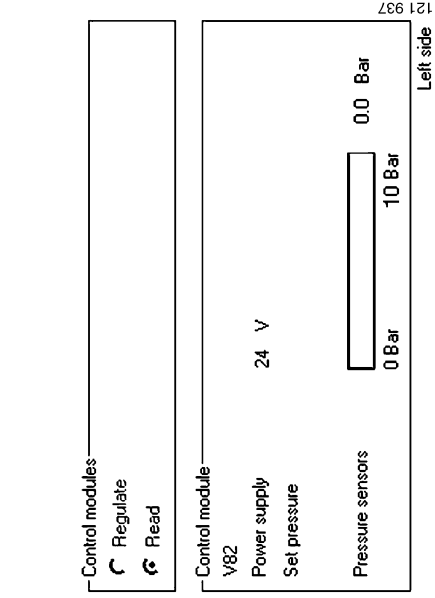
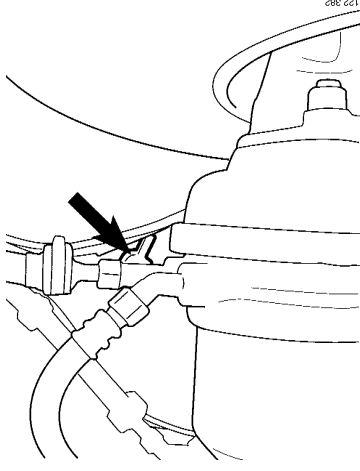

Test connection 5, rear axle

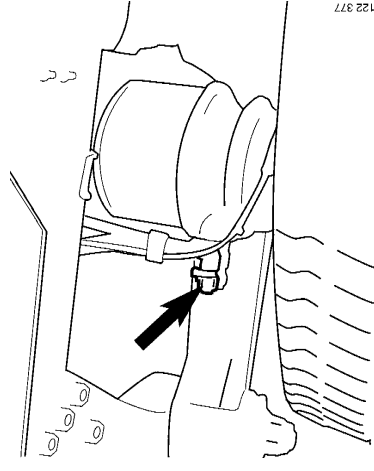

Test measure	Limit values	Cause of fault / action
Supply voltage Pressure set in Diagnos/Pressure gauge reading Pressure via brake pedal/Pressure reading in Diagnos	20.0 - 29.0 V +/- 0.25 bar +/- 0.40 bar	If the value is too low, the fault will be found in the control module or the cables.
<ul style="list-style-type: none"> - Connect 2.5 bar pressure gauges to the test connections on the relevant axle. - Select "Activate" in Scania Diagnos. - Set the desired pressure via Scania Diagnos in 4 steps according to point 14 on the report. - Then compare the pressure setting with the reading on each pressure gauge. - Change to 15 bar pressure gauges. - Select "Take reading" in Scania Diagnos. - Depress the brake pedal to 1, 3 and 6 bar on the pressure gauge. - Compare the value at "Pressure sensor" in the Diagnostic window with the pressure gauge. 	Test connection (bar) 5	<p>Maximum permitted deviation: +/- 0.25 bar. If the two values are not the same, there may be a fault in the control module, its connections or in the electric and air lines to and from the control module.</p> <p>Permitted deviation between pressure sensor and pressure gauge: +/- 0.4 bar. The higher permitted deviation is due to the low precision of the 15 bar pressure gauges.</p>

15. Testing trailer relay valve

IMPORTANT! This test is **not** valid for vehicles with EBS 2.2 with electronic trailer control module TCM.

Note: When measuring **increasing pressure** you may **only depress the brake pedal or keep it still**. If the brake pedal is released when measuring increasing pressure, the test result will be incorrect.

When measuring **falling pressure** you may **only release the brake pedal or keep it still**. If the brake pedal is depressed when measuring falling pressure, the test result will be incorrect.

Equipment/Pressure gauges

2.5 bar	15 bar
2	--

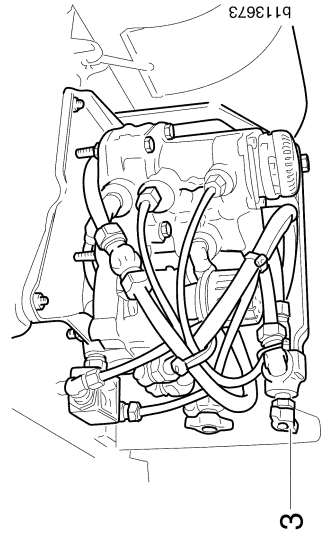

Test connection 3

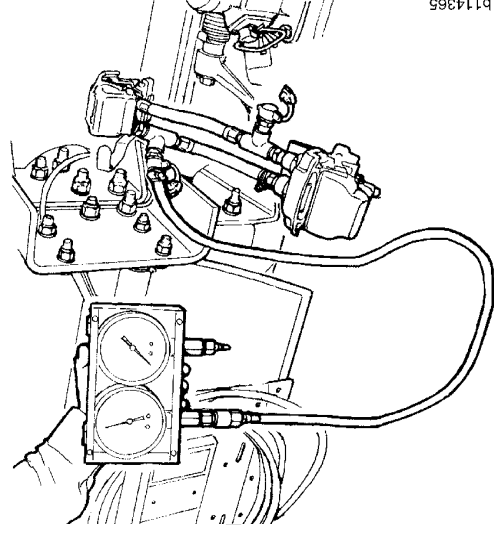

Test connection 8

Test measure	Test connection (bar)		Cause of fault / action
<ul style="list-style-type: none"> - Connect the pressure gauges to test connections 3 and 8. - Brake in 5 steps according to point 15 on the report. Measure the deviation between test connections 3 and 8. Make a note in the report. 	3	8	<p>The pressure level set at the factory at 0.3 bar should normally not be changed. For more information on settings, see main group 10 Trailer brake circuits, Components.</p> <p>If pressure at test connection 8 rises or drops in steps, the trailer relay valve is binding and may soon cause problems.</p>

16. Checking regulated pressure and backup pressure from electronic trailer control module, TCM-EBS 2.2

Equipment/Pressure gauges

2.5 bar	15 bar
1	1

A voltage should be displayed for "Supply voltage". Each control module will show its own voltage value.

Use the "Activate" button to pressurise the trailer brake chamber using Scania Diagnostics. Set the pressure with the "Set pressure" slider.

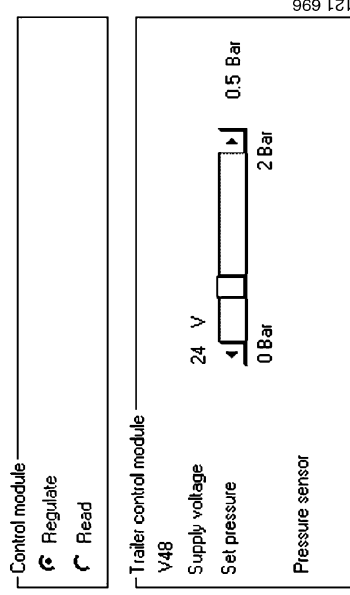

Choose "Take reading" to pressurise the control module with the brake pedal. Depressing the brake pedal will send air fully pneumatically to the trailer brake connector.

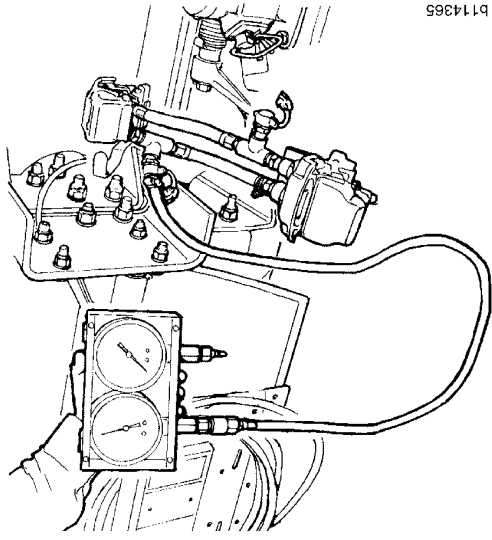
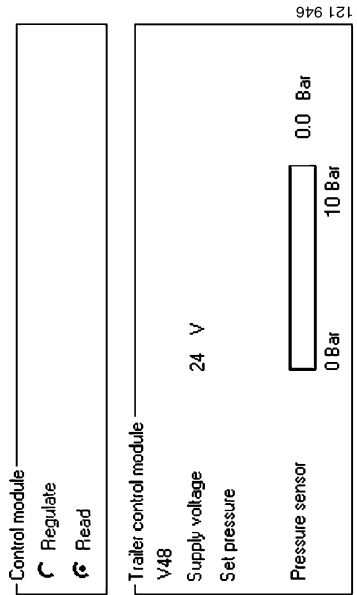

Test connection 8

Test measure	Limit values	Cause of fault / action
Supply voltage Pressure set in Diagnos/Pressure gauge reading Pressure via brake pedal/Pressure reading in Diagnos	20.0 - 29.0 V +/- 0.25 bar +/- 0.40 bar	If the value is too low, the fault will be found in the control module or the cables.
<ul style="list-style-type: none"> - Connect a 2.5 bar pressure gauge to the trailer brake connection 8. - Set the desired pressure via Scania Diagnos in 4 steps according to point 16 on the report. - Then compare the pressure setting with the reading on the pressure gauge. - Change to a 15 bar pressure gauge on the trailer brake connection 8. - Select "Take reading" in Scania Diagnos. - Depress the brake pedal to 1, 3 and 6 bar on the pressure gauge. - Compare the value at "Pressure sensor" in the Diagnostic window with the pressure gauge. - Make a note in the report, point 16. 	Test connection (bar) 8	<p>Maximum permitted deviation: +/- 0.25 bar. If the two values are not the same, there may be a fault in the control module, its connections or in the electric and air lines to and from the control module.</p> <p>Permitted deviation between pressure sensor and pressure gauge: +/- 0.4 bar. The higher permitted deviation is due to the low precision of the 15 bar pressure gauges.</p>

17. Testing the trailer relay valve/trailer control module discharge function

IMPORTANT! Make sure the starter key is in drive position, +15V.

Equipment/Pressure gauges

2.5 bar	15 bar
--	1

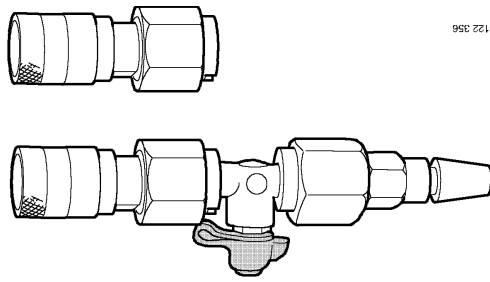

BSI connector

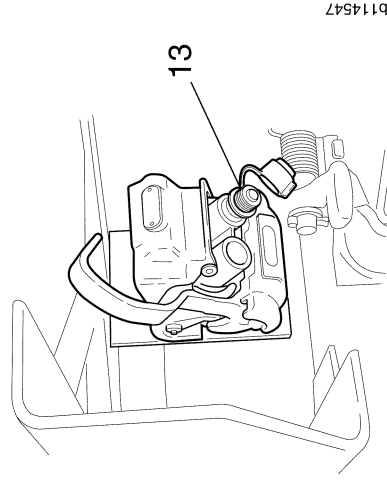

Test connection 13 with in-house manufactured tools for vehicles with Duo-Matic coupling.

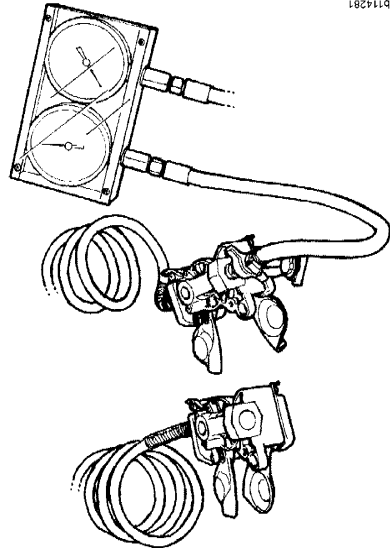

Example of test connection 13 and in-house manufactured tools for vehicles with ISO coupling.

Test measure	Test connection (bar) 13	Cause of fault / action
<ul style="list-style-type: none"> - Make a tool as described in <i>In-house manufactured tools</i>. - Place chocks in front of and behind the wheels. - Release the parking brake. - Connect the tool and pressure gauge to test connection 13. - Charge the system with air. The pressure gauge should now show full supply pressure. - Quickly depress the brake pedal fully. The supply pressure should drop to less than 1.5 bar in maximum two seconds. 	<p style="text-align: center;">< 1.5</p>	<p style="text-align: center;">If the value is incorrect, the trailer relay valve must be replaced.</p>

18. Checking communication with trailer equipped with EBS

IMPORTANT! The vehicle must be stationary during the test!

- The slider control can be used to check that the CAN signals are reaching the trailer EBS control unit. Use the slider control to govern the trailer control module.



Test measure	Cause of fault / action
<ul style="list-style-type: none"> - Connect a pressure gauge to one of the trailer brake chambers. - Regulate the pressure from one of the control modules using the slider. 	<p>The regulated pressure is limited in time. It will be reset to 0 bar after five minutes.</p> <p>Note that this function may set fault codes in the trailer control unit. This is due to the electronic and pneumatic signal to the trailer not corresponding with each other.</p>

19. Checking secondary brake valve, T-vehicles 4x2 with EBS 2.2

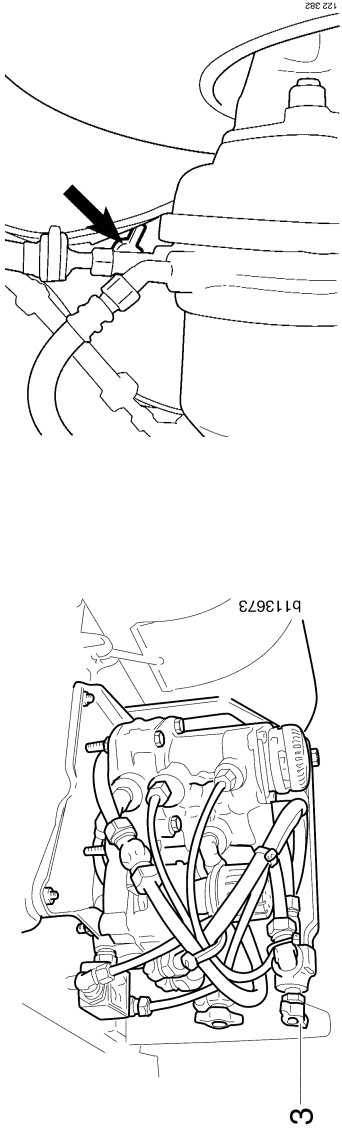

Test connection 3

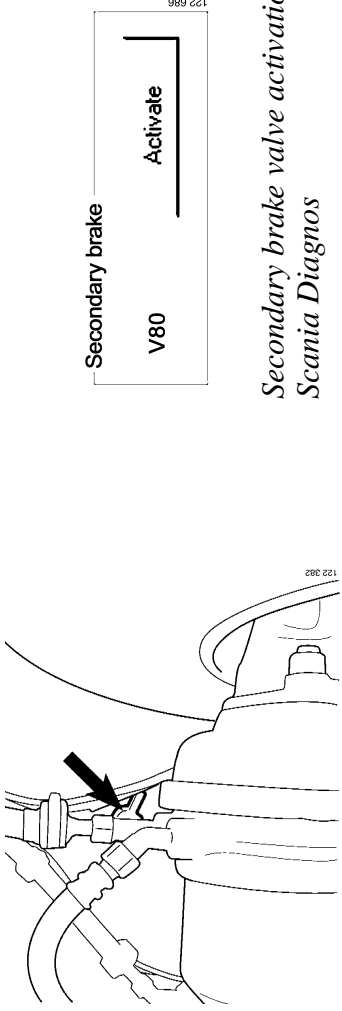

Secondary brake valve activation button in Scania Diagnos

Test connection 5, front axle

Test measure	Test connection		Scania Diagnos V 82	Cause of fault / action	
<ul style="list-style-type: none"> - Apply the parking brake. - Connect a 2.5 bar pressure gauge to the left brake chamber on the front axle. Test connection 5. - Connect a 15 bar pressure gauge to the rear circuit, test connection 3 on the centre valve assembly. - Apply a pressure of 0.5 bar to the left side with Scania Diagnos. - Use the foot brake to attain a pressure of 1.0 - 1.5 bar to the front brakes. - Activate the secondary brake valve with Scania Diagnos. 	5	3	0.5	The front left brake should be applied when the pressure in the rear circuit increases. The front left brake should return to a pressure of 0.5 bar.	

20. Checking wheel sensors



WARNING!

This test requires two people. One to drive the vehicle and one to check Scania Diagnostics.

121 694

- Axle 1			
T11	Wheel sensor	0	km/h
			Left
T12	Wheel sensor	0	km/h
			Right

- Axle 2			
T13	Wheel sensor	0	km/h
			Left
T14	Wheel sensor	0	km/h
			Right
- Axle 3			
T28	Wheel sensor	0	km/h
			Left
T30	Wheel sensor	0	km/h
			Right

Current wheel sensor speed

121 693

Wheel sensor	
T11	
Vehicle speed	0 km/h
Start speed	9 km/h
	Left side

Wheel sensor starting speed

Test measure	Limit values		Cause of fault / action						
<p>Starting speed:</p> <ul style="list-style-type: none"> - The starting speed is the speed at which the wheel sensor will deliver a signal that is strong enough for the wheel speed to be measured. The stored starting speed displayed in the window is the latest starting speed that was registered during the previous trip. <p>Checking speeds</p> <ul style="list-style-type: none"> - Drive the vehicle at 20 km/h and 40 km/h and compare the speed reading from the wheel sensors with the vehicle's speedometer. 	<p>Max. 12 km/h</p>	<table border="1"> <thead> <tr> <th data-bbox="536 1077 580 1344">Speedometer</th> <th data-bbox="536 815 580 1077">Scania Diagnos</th> </tr> </thead> <tbody> <tr> <td data-bbox="580 1077 732 1151">20 km/h</td> <td data-bbox="580 815 732 1077">18 - 22 km/h</td> </tr> <tr> <td data-bbox="580 1151 732 1344">40 km/h</td> <td data-bbox="580 1077 732 1151">36 - 44 km/h</td> </tr> </tbody> </table>	Speedometer	Scania Diagnos	20 km/h	18 - 22 km/h	40 km/h	36 - 44 km/h	<p>The starting speed is only displayed numerically. If the starting speed is above 12 km/h, check the wheel bearing play, adjust the wheel sensor and check the toothed wheel trueness.</p>
Speedometer	Scania Diagnos								
20 km/h	18 - 22 km/h								
40 km/h	36 - 44 km/h								

21. Checking retarder torque



This test requires two people. One to drive the vehicle and one to check Scania Diagnos.

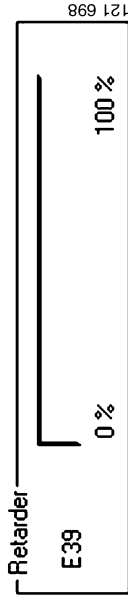

Test measure	Cause of fault / action
<p>- Drive the vehicle and activate the retarder.</p>	<p>Check that the bar shown in the Retarder window in Scania Diagnos is displaying the operation of the retarder.</p> <p>The retarder control unit sends the current retarder torque to the EBS control unit, which uses the information to estimate whether the brake adaptation is correct.</p> <p>By reading this signal, it is possible to confirm that the communication between EBS and the retarder is functioning properly.</p>