

SCANIA

After Sales Services

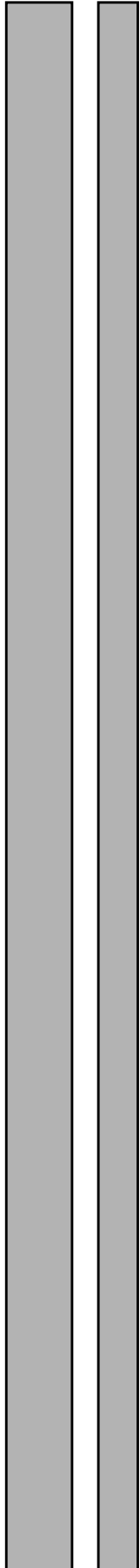

Bosch ABS/TC "CP12" 4-channel system

Work description

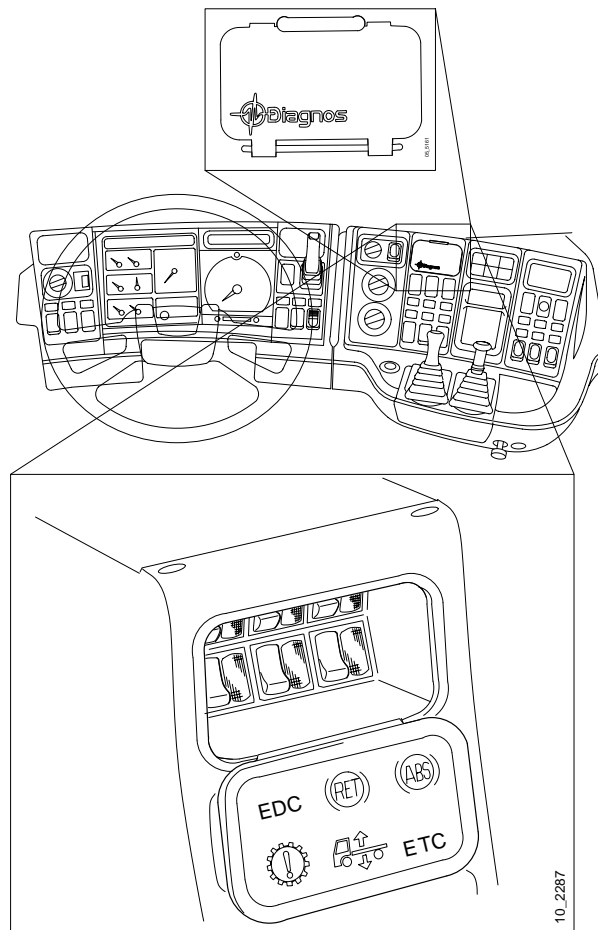

Part No., control unit

1 382 748

Manufacturer number

0 265 150 351

Contents

General	3
	New features	4
Scania Diagnostics, ABS/TC	Diagnostic panel	5
	Diagnostic memory feature	5
	Appearance and structure of flashing codes	6
	Erasing fault codes	6
Fault diagnosis	Testing using a multimeter	7
	Conducting fault diagnosis	7
	Flashing codes	8
	Limits for front and rear wheel rolling circumference	13
Electrical system	Wiring diagrams	15
	Associated diagrams in group 16	16
	Colour codes for electrical wiring	16
	Location of components	17
	Wiring diagrams	18
	Input signals	28
	Output signals	29
	Other connections	30
	Pin numbering	31
Specifications	32

General

This Bosch ABS/TC system has a new generation of control unit which is different from the previous one. The main differences are CAN communication with the EDC control unit and modified TC control.

All the differences compared with the previous generation of ABC/TC are dealt with on the next page under the heading “New features”.

New features

The electrical differences in this version of Bosch ABS/TC compared with the previous version are as follows:

- The brake light switch must have been activated (brake pedal depressed) for TC to work. The TC warning lamp goes out when this is done. This is a safety feature.
- The supply relays (R7 and R8) for wheel diagonals have been discontinued. These relays are now integrated in the control unit.
- The ABS warning lamp goes out after about 3 seconds if there were no faults the last time the control unit was powered. This feature is used to enable the control unit to be able to display faults which arose during earlier driving when power is switched on and the vehicle stationary.
- ABS warning lamp relay (R10) is no longer fitted. When the ABS/TC control unit is removed, the ABS warning lamp is now lit by a circuit breaker, located in the connector to the control unit.
- Information exchange with other control units in the vehicle is via CAN communication.

Mechanical differences compared with previously:

- The TC solenoid valve with dual solenoids has been replaced by a single solenoid. The solenoid valve is normally closed.

For more detailed description, see ABS/TC description of operation.

Scania Diagnos, ABS/TC

Diagnostic panel

This version of the Bosch ABS/TC has an integrated fault diagnosis system. The diagnostic panel is located on the instrument panel and consists of a switch for activating and erasing the diagnostic memory, as well as a diagnostic lamp for flashing codes.

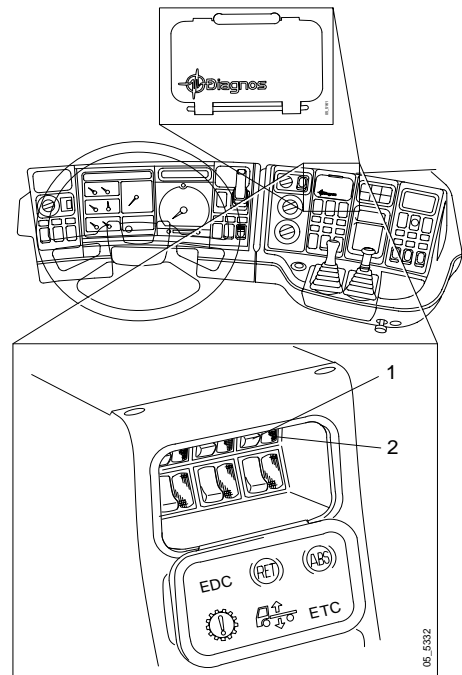

1 Diagnostic switch ABS/TC

2 Diagnostic lamp

Diagnostic memory operation

A maximum of five fault codes can be stored. If a sixth fault arises this replaces the first code which was stored. The last code to be stored is displayed first. This fault must be rectified and the fault code cleared before the next fault can be displayed. A maximum of two faults can be displayed in one flashing sequence.

Continued on next page >

Appearance and structure of flashing codes

Switch on the power. Flashing codes are displayed if the diagnostic switch is then depressed for at least 1 second. The flashing code consists of four different blocks/flashing sequences with an interval of 1.5 seconds, see figure.

- 1 The first block shows whether the system is an ABS or an ABS/TC system. This time the lamp should flash two or five times.
- 2 The second block shows what type of control the front axle has (see page 8 for explanation). The lamp should flash twice this time.
- 3 The third block shows any faults in the first wheel diagonal (left front-right rear).
- 4 The fourth block shows any faults in the second wheel diagonal (right front-left rear).

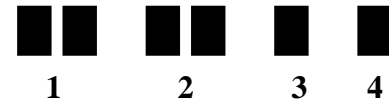

Example shows an ABS system with MIR control on the front axle and no fault in the wheel diagonals.

■ = Light pulse/flash

Erasing fault codes

- 1 Switch off starter voltage.
- 2 Press the diagnostic switch.
- 3 Switch on the power and hold the diagnostic switch depressed for at least 1 second.

Fault diagnosis

Testing using a multimeter

There is no Scania test instrument that fits the 55 pin connector. Resistance and voltage must instead be measured using a multimeter directly on the connector to the control unit.

N.B. The 55 pin connector is fragile. Do not therefore push the multimeter probe into the connector but simply hold it against the pin. There is no safe way of activating relays and control valves. It is theoretically possible but there is a serious risk of damaging the connector.

How to conduct fault diagnosis

- 1 Press the diagnostic switch for ABS/TC for at least 1 second and read the flashing code.
- 2 Check if there are any faults as described on the tables on pages 8 and 9.
- 3 If there is a fault, read the flashing code text and read which circuit in the wiring diagrams applies. If you are unsure about the significance of component designations, check this in the "Wiring diagrams manual".
- 4 Choose a suitable connector on which to take a reading and find the connector with the help of the component drawing. It is preferable not to take measurements in the control unit connector. This is difficult and it is easy to damage the connector.
- 5 Take readings using a multimeter and check the values on pages 28-32.

Flashing codes

First block/flashing sequence

Number of flashes	Type of system
2	ABS
5	ABS with TC braking and engine control

Second block/flashing sequence

Number of flashes	Type of system
2	Modified independent control on front axle (MIR)

Third block/flashing sequence = Diagonal 1 (FL/RR)
Fourth block/flashing sequence = Diagonal 2 (RF/RL)

Number of flashes	Type of fault	See current circuit
1	No fault localized	-
2	Fault in control unit	-
3	Prohibited air gap or short circuit, front wheel sensor	5, 18
4	Prohibited air gap or short circuit, rear wheel sensor	10, 22
6	Break or short circuit, front wheel sensor	5, 18
7	Break or short circuit, rear wheel sensor	10, 22
9	Voltage too low to control unit (pin 38) or to control valve (diagonal 1, pin 28 and diagonal 2, pin 5)	190, 188, 189
10	Break or short circuit, front control valve	33, 58, / 83, 107
11	Break or short circuit, rear control valve	40, 65 / 90, 115
13	Relay in control unit not earthed or break in cable between control unit and control valve	33, 40, 58, 65 / 83, 90, 107, 115
14	Break or short circuit, TC solenoid valve	232
15	ABS/TC control unit cannot communicate with the interface for engine management (EDC)/Break or short circuit, proportional valve or tachograph signal	205 / 246 / 241
18	Difference in diameter between front and rear wheels excessive	-
19	Short circuit to +24 V or earth, DBR cable	130
20	CAN communication fault	205
21	Brake light switch defective or has not been activated	196

Comments

CAN Communication

CAN: Stands for controller area network. CAN communication is used to reduce the number of cables in the vehicle. This is intended to increase reliability.

CAN communication takes place in series. In vehicles with ABS/TC, there is a communications circuit which communicates with other control units via two lines called CAN high (pin 47) and CAN low (pin 48).

In simple terms it can be said that CAN communication is similar to radio technology. The data signals which pass through a CAN lead can be compared to radio waves in the air.

When listening to the radio, the receiver is set so that one radio station is heard at one time. This is the only station that can be heard, despite the fact that there are many radio stations broadcasting at the same time.

A control unit does more or less the same thing with the data which comes through a CAN lead. For example, it listens for information from the EDC about engine torque, receives this value and uses it in calculations.

The control unit receives all CAN signals which are sent through the communications circuit in a special memory. This memory can be compared to several radio receivers which are switched on, but which are all set to different radio stations in order to listen to several particular radio programs at the same time. In this way, the control unit continuously senses what is happening.

This is nothing that the mechanic need to worry about.
The only thing to remember is that it is not possible to check individual CAN signals using a multimeter.

Flashing code 15

This flashing code can be generated due to the following:

- The ABS/TC control unit is unable to make contact with the engine control interface (EDC).
- Break or short circuit in cable to proportional valve.
- Faulty tachograph.

The ABS/TC control unit is unable to make contact with the engine control interface (EDC): The ABS/TC control unit has, for example, sent a message to the EDC control unit about reduction of engine torque.

The ABS/TC control unit then receives no confirmation that this has been carried out by the EDC control unit. The ABS/TC control unit generates a fault code after repeated attempts.

Action: Check to see whether there are any fault codes stored in the EDC control unit. Check connectors and wiring in the communications circuit.

Incorrect values may be of the type which are continuously sent by the EDC control unit or an order from the ABS/TC control unit which is then confirmed incorrectly by the EDC control unit. The ABS/TC control unit generates a fault code after repeated fault messages.

Action: Check to see whether there are any fault codes stored in the EDC control unit. Check connectors and wiring in the communications circuit.

Fault in communication circuit: The control unit has sensed that an open circuit or short circuit has arisen somewhere beyond pins 47 and 48.

Action: Check connectors and wiring. If these are not at fault, then the control unit is faulty, but there is not much chance of this.

Flashing code 20

This flashing code can be generated for two reasons:

- Time limit between transmission attempts exceeded or impossible value.
- Fault in communications circuit.

Exceeded time limit between transmission attempts: The ABS/TC control unit has, for example, sent a message to the EDC control unit about reducing engine torque.

It then takes too long before the EDC control unit has confirmed that reduction has been carried out. The ABS/TC control unit generates a fault code after repeated attempts.

Impossible value: The values sent by the EDC control unit are considered as impossible by the ABS/TC control unit. This may be information such as engine torque.

Flashing code 21

The vehicle's TC feature is disengaged when the brake light switch is activated. This is carried out so that it is not possible for the vehicle to roll forward or backwards when the control unit is carrying out TC control and the vehicle is then braked.

As a safety feature, brake light switch operation must be checked each time the ignition is switched on by pressing the brake pedal. The TC warning lamp then goes out. If the brake light switch is faulty or has not been activated, TC is unable to provide control and the warning lamp will remain lit.

TC control does not thus work when the brake light switch is jammed, fuse (number 6) for the brake light relay has blown or when all brake light lamps are broken. The probability of all lamps breaking at the same time is however small.

If the ABS/TC diagnostic switch is activated before the brake pedal is depressed, flashing code 21 is displayed. This flashing code is never permanently stored in the memory but disappears as soon as the ignition is switched off. However, it is generated immediately when the ignition is switched on and then disappears when the brake light switch has been activated.

Rolling circumference limits for front and rear wheels

In vehicles with ABS/TC an excessive difference between the rolling circumference of the front and rear wheels may give incorrect signals to the control unit resulting in longer braking distances. Use the values of tyre rolling circumference given by the manufacturer and choose tyres so that the difference is no greater than

- + 14.0 % if the front wheels are larger than the rear wheels.
- 14.0 % if the front wheels are smaller than the rear wheels.

$$\text{Difference (\%)} = \frac{\text{Front rolling circumference} - \text{Rear rolling circumference}}{\text{Front rolling circumference}} \times 100$$

Example:

Tyre, front axle: 315/80R 22.5
Rolling circumference: 3329 mm

Tyre, rear axle: 12R 22.5
Rolling circumference: 3360 mm

$$\text{Difference (\%)} = \frac{3329 - 3360}{3329} \times 100 = -0,9 \%$$

This difference is permitted as it may be up to -14.0 %.

Electrical system

Wiring diagrams

- The flashing codes table earlier in this booklet refers to current paths.
- The wiring diagrams follow the component drawings. These have current path serial numbers. Use the references to the current circuits from the table for flashing codes in order to find the correct diagram and the components in question.
- The diagrams use component name e.g. E37. The full name of the components is given in the "Wiring diagrams manual" in group 16 of the workshop manual.

Associated diagrams in group 16

Connection diagram

16:04-31

Colour codes for electrical wiring

BK	Black
BN	Brown
RD	Red
OG	Orange
YE	Yellow
GN	Green
BU	Blue
VT	Violet
GY	Grey
WH	White
PK	Pink

Location of components

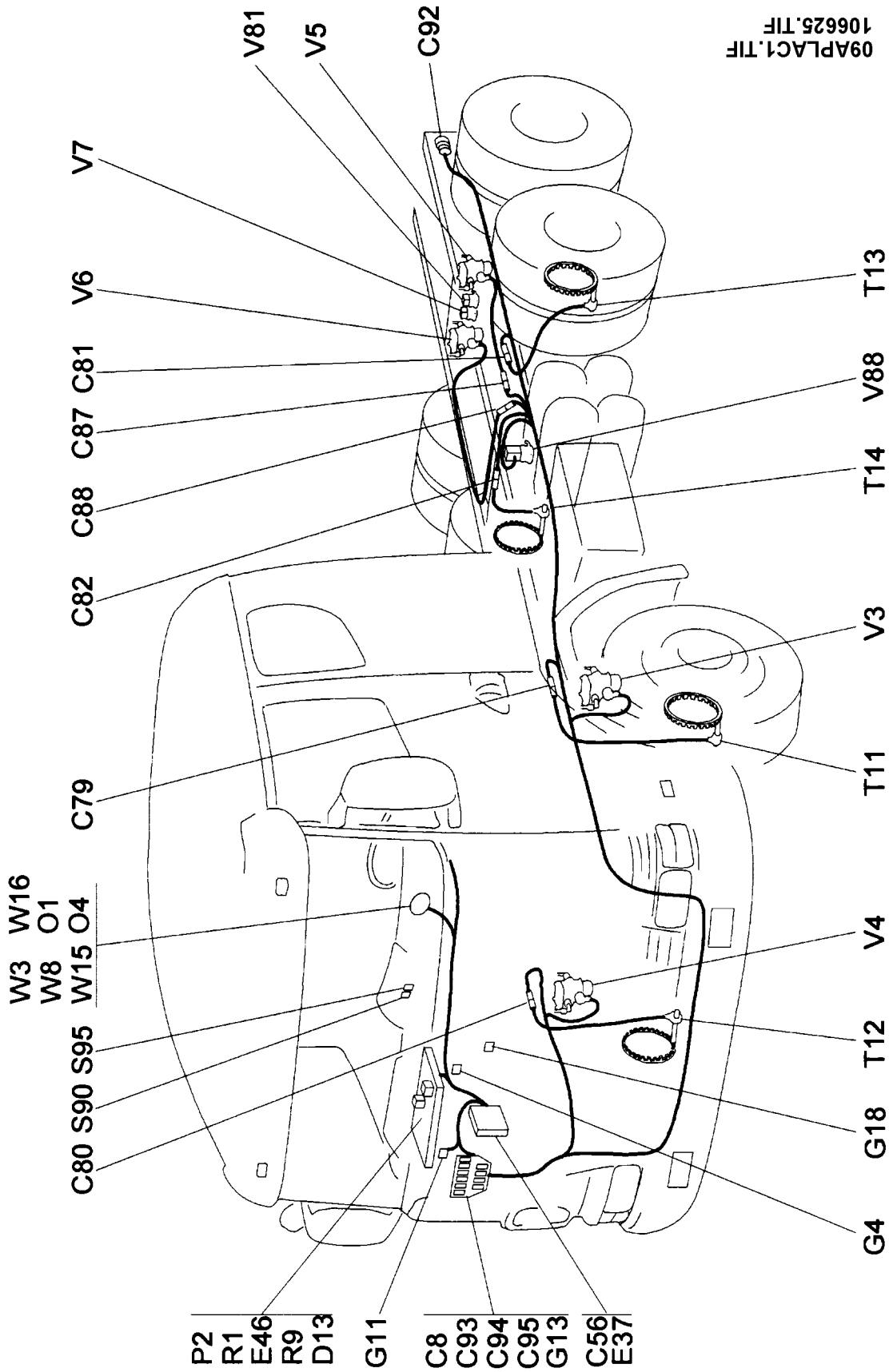

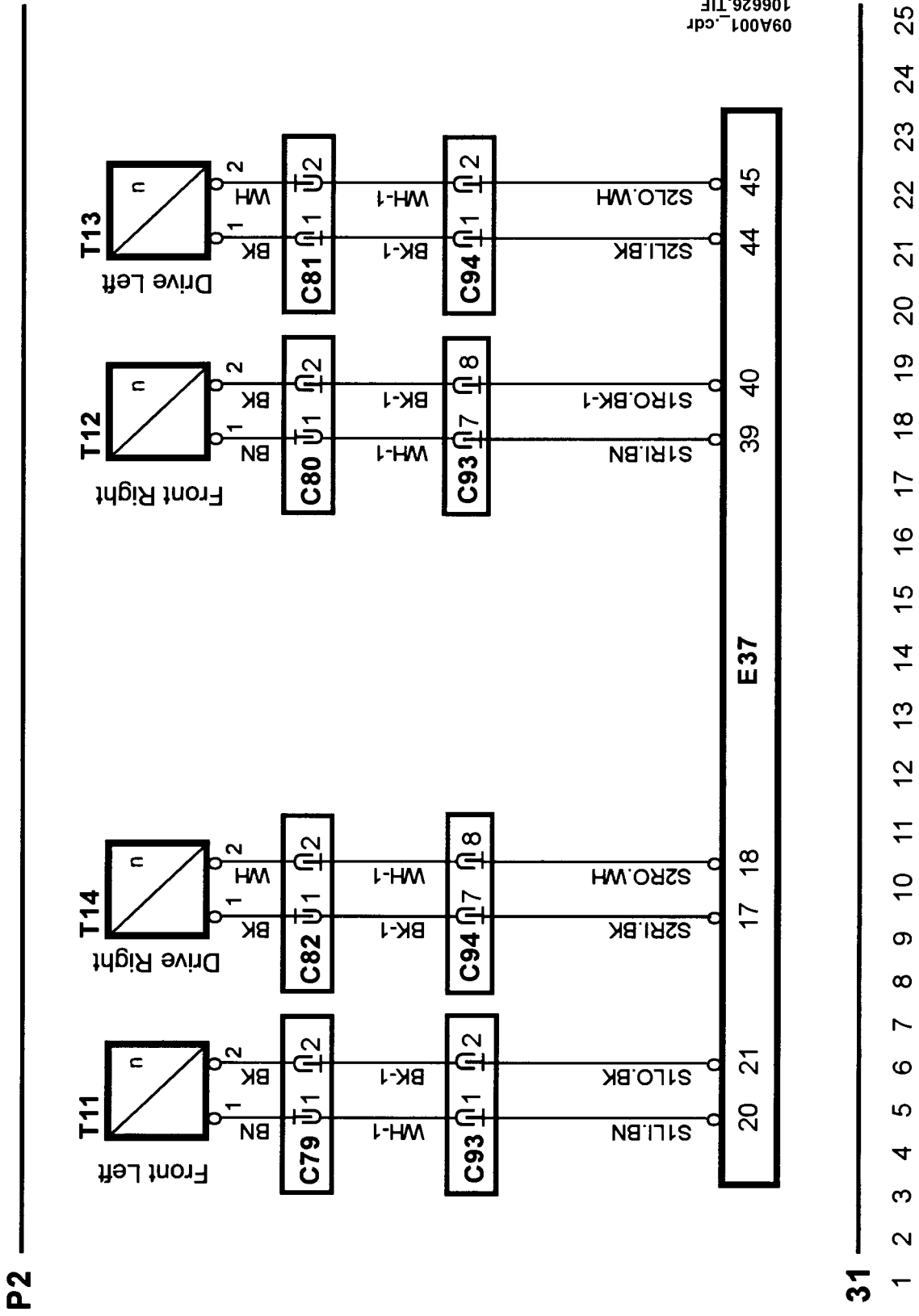

P2

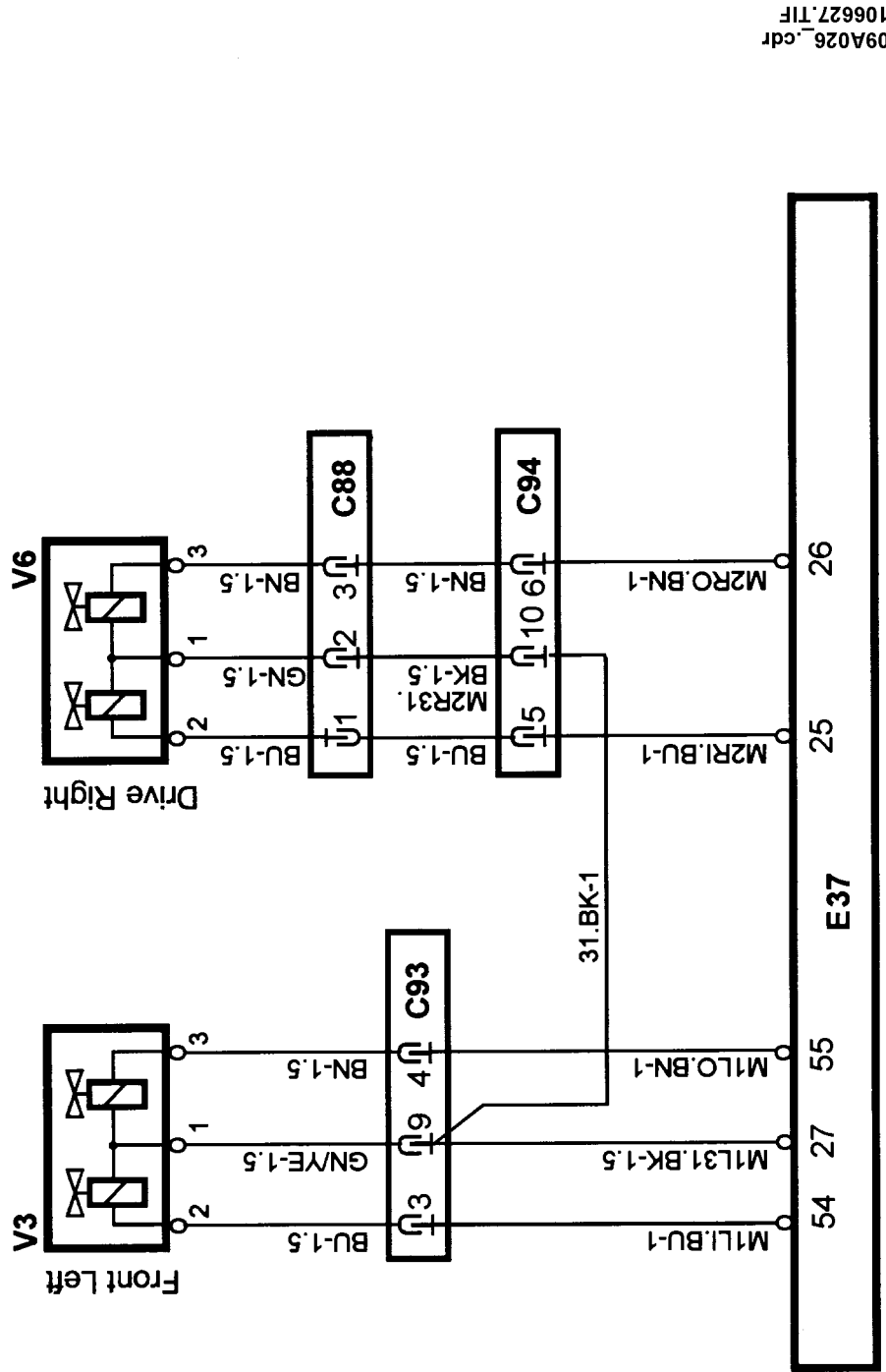

09A026_cdr
106627.TIF

31

26 27 28 29 30 31 32 33 34 35 36 37 38 39 40 41 42 43 44 45 46 47 48 49 50

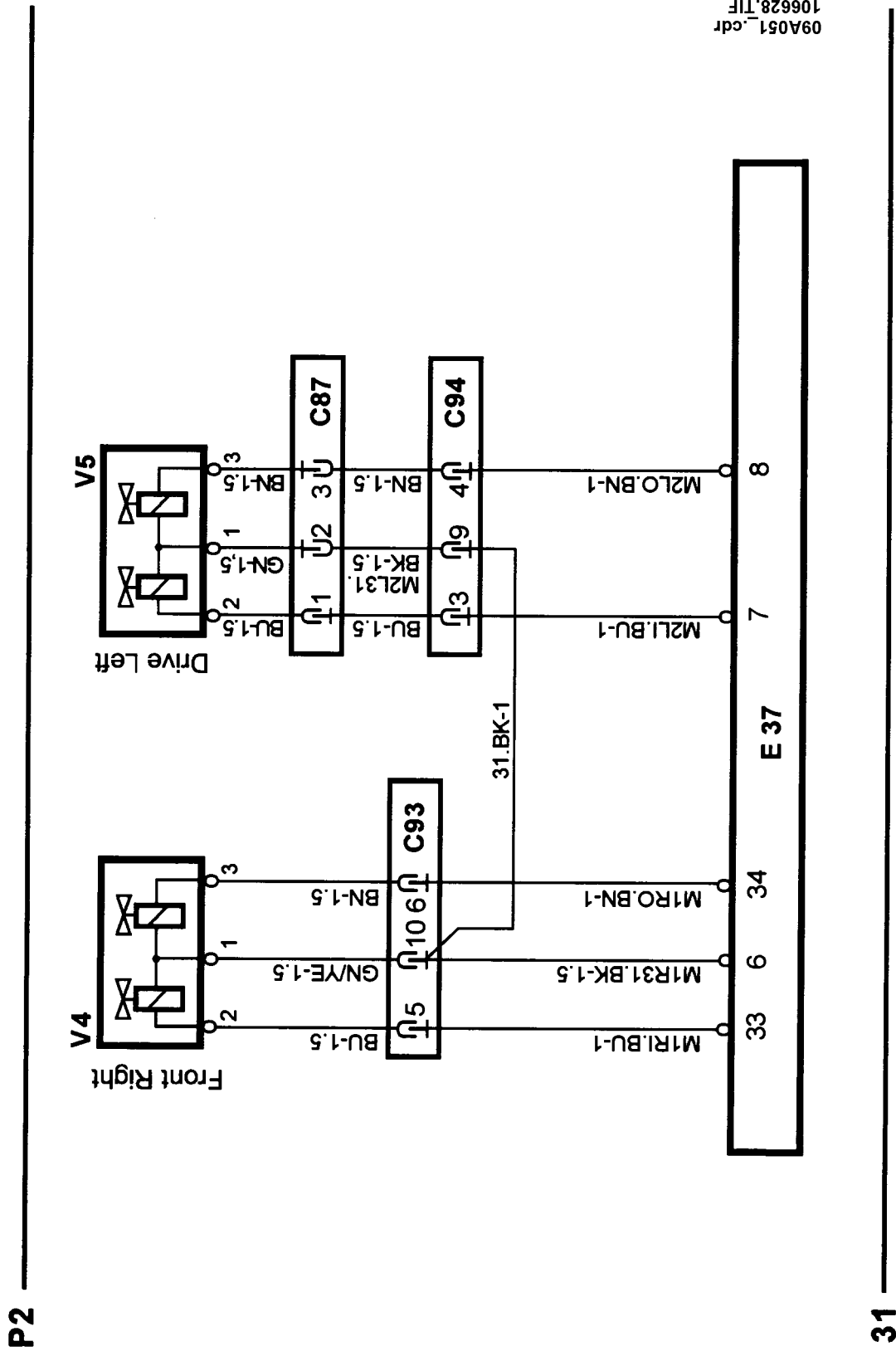

09A051_cdr
106628.TIF

51 52 53 54 55 56 57 58 59 60 61 62 63 64 65 66 67 68 69 70 71 72 73 74 75

P2

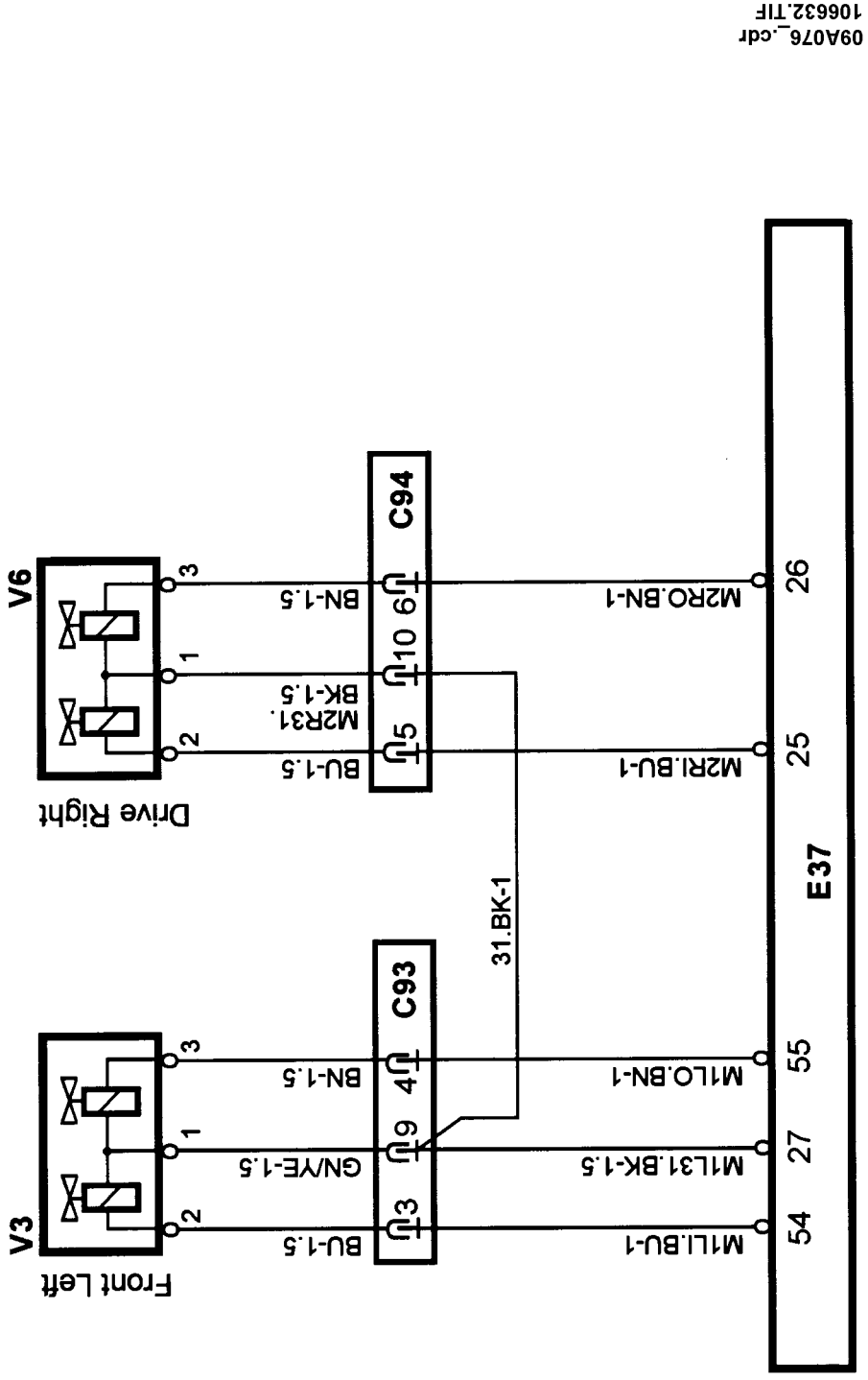

09A076_cdr
106632.TIF

31

- 76
- 77
- 78
- 79
- 80
- 81
- 82
- 83
- 84
- 85
- 86
- 87
- 88
- 89
- 90
- 91
- 92
- 93
- 94
- 95
- 96
- 97
- 98
- 99
- 100

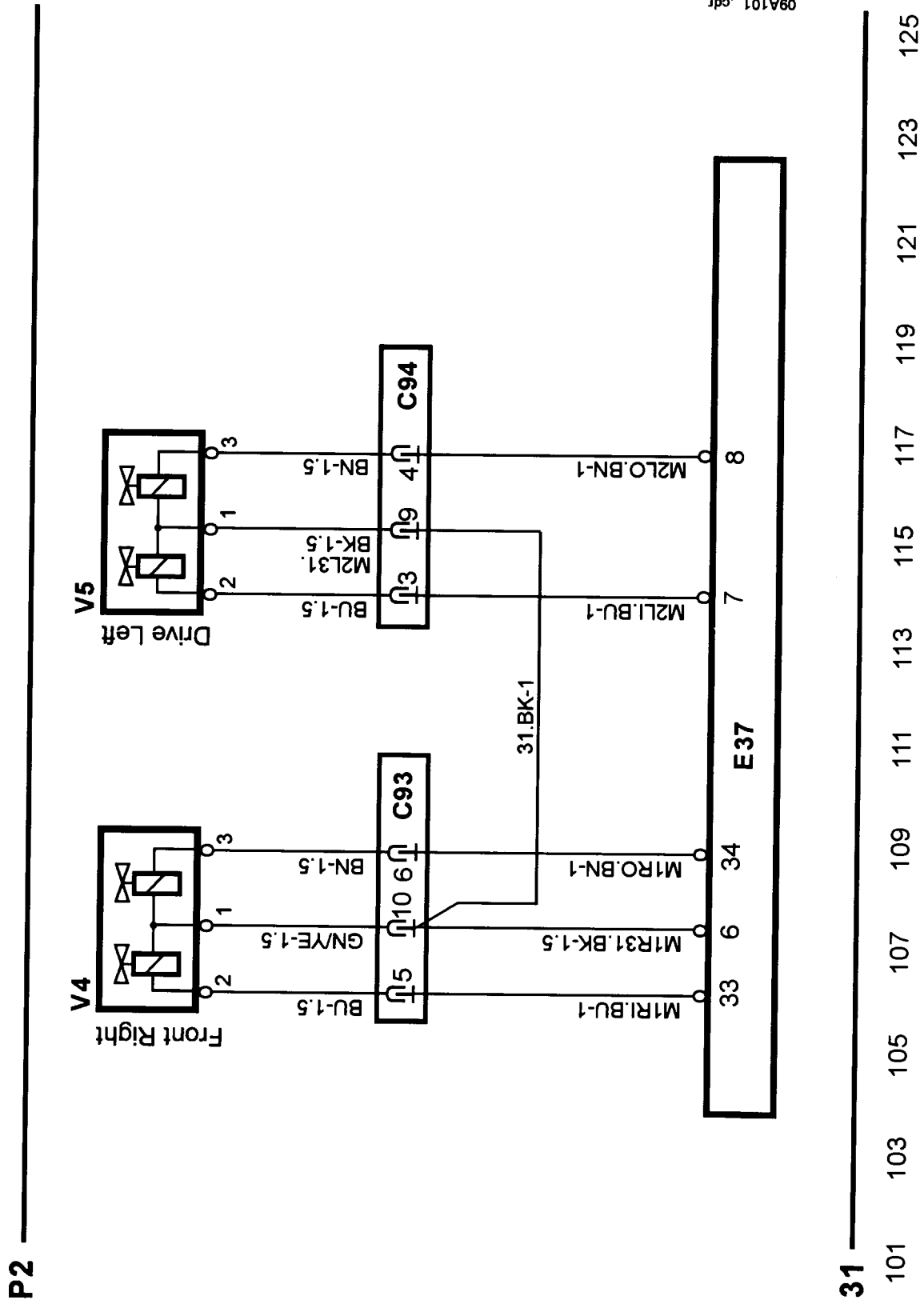

09A101.cdr
106633.TIF

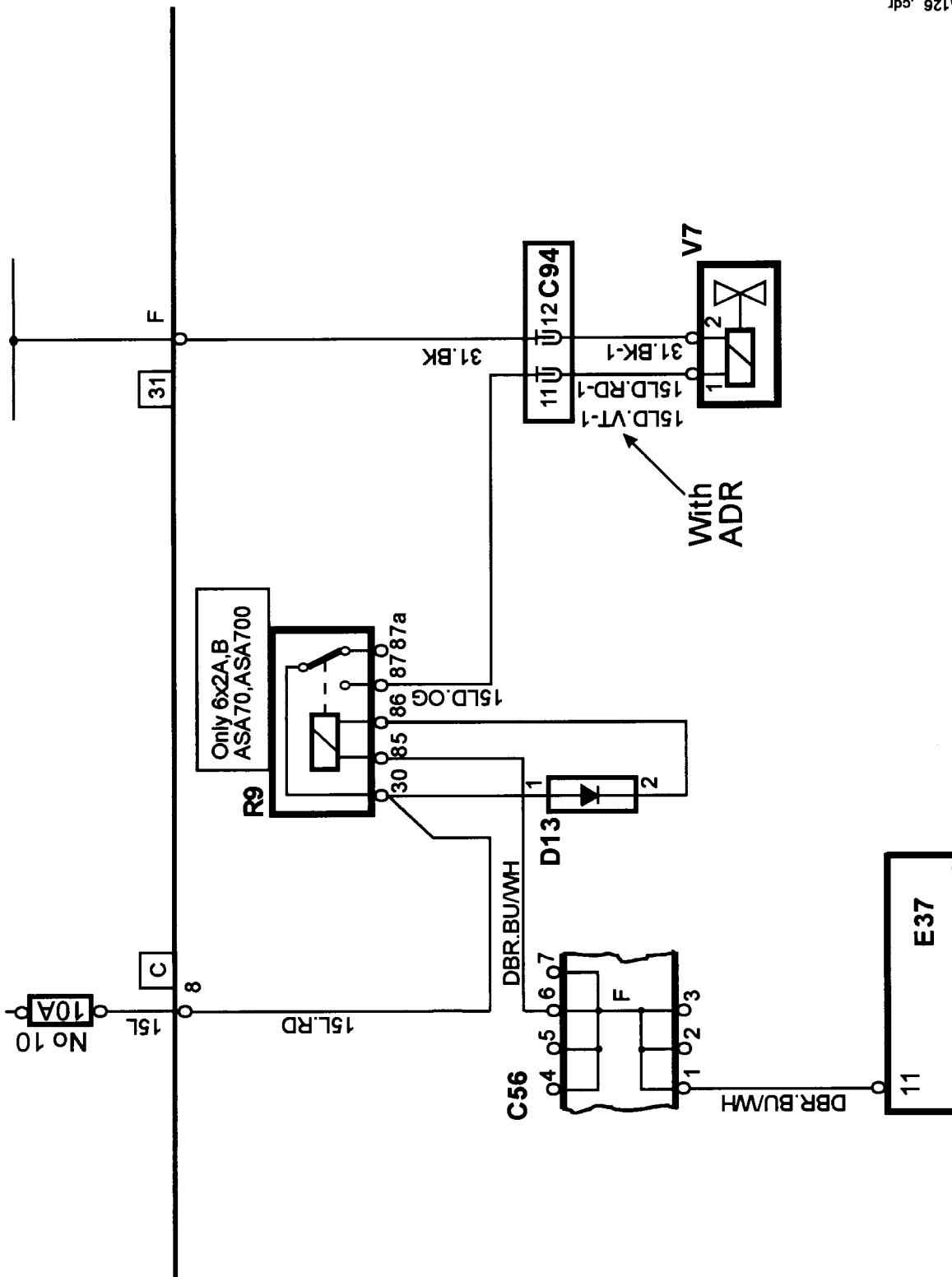

09A126_cdr
106634.TIF

31 — 126 128 130 132 134 136 138 140 142 144 146 148 150

cardiagn.com

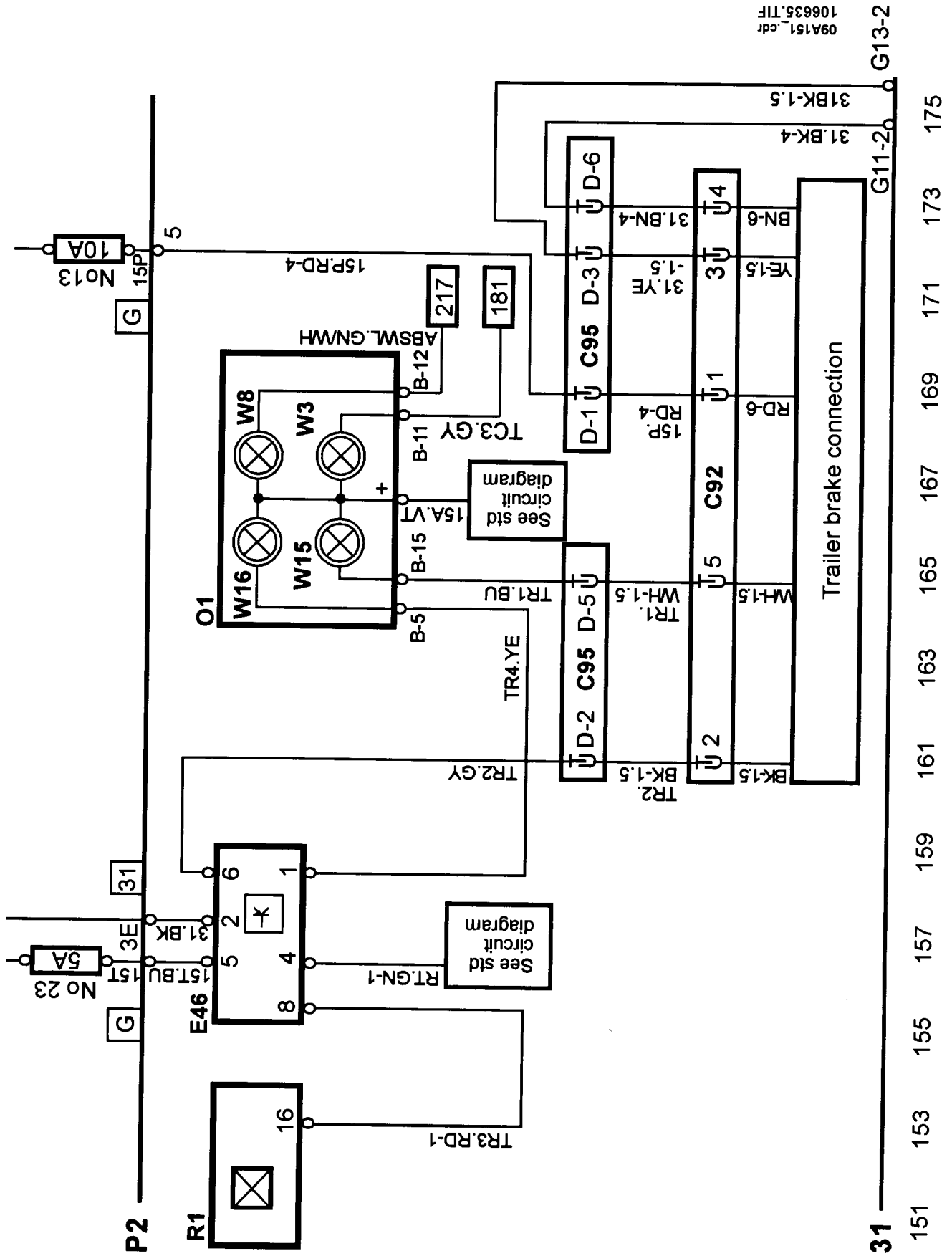

09A151_cdr
106635.TIF

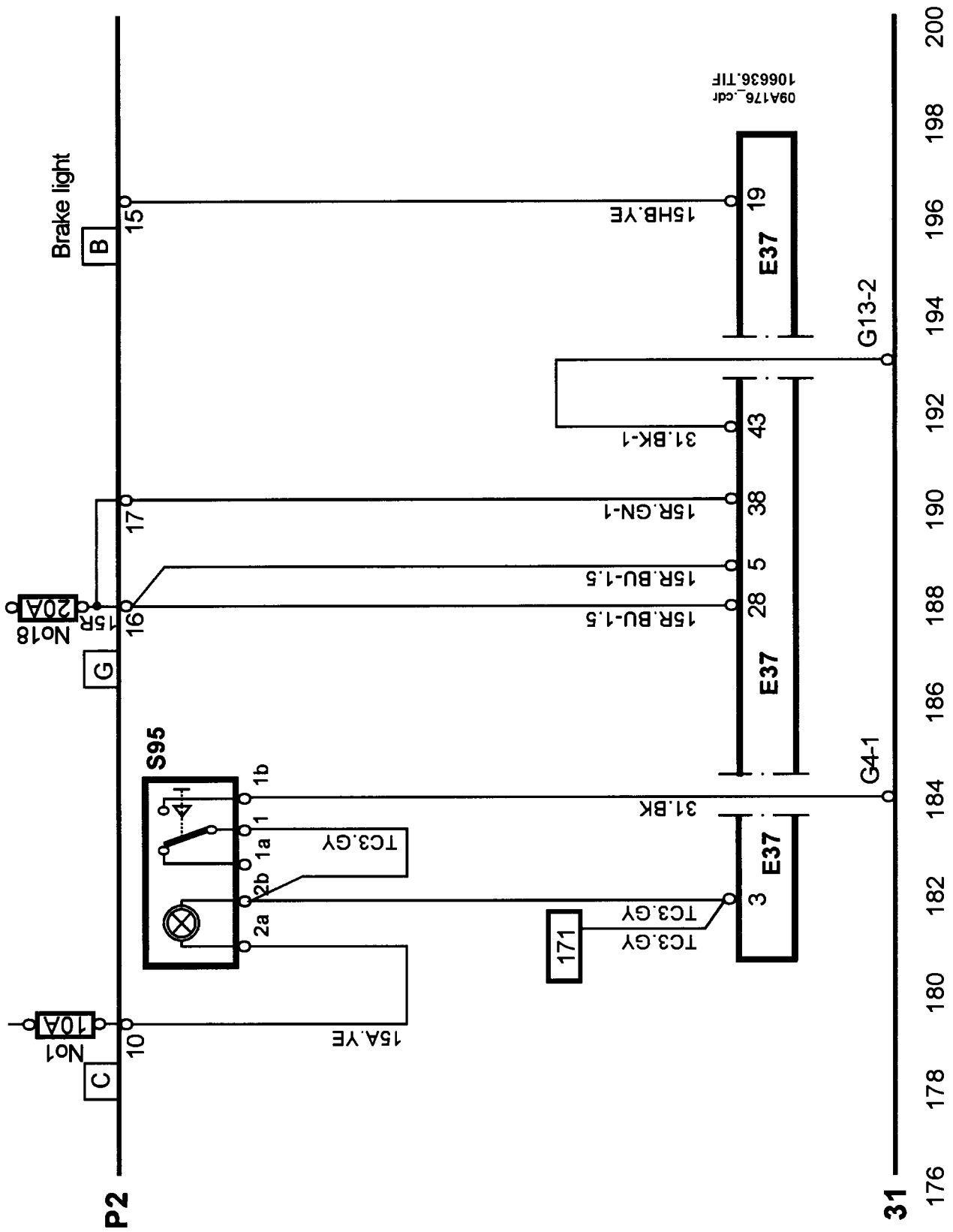

09A176_cdr
106636.TIF

cardiagn.com

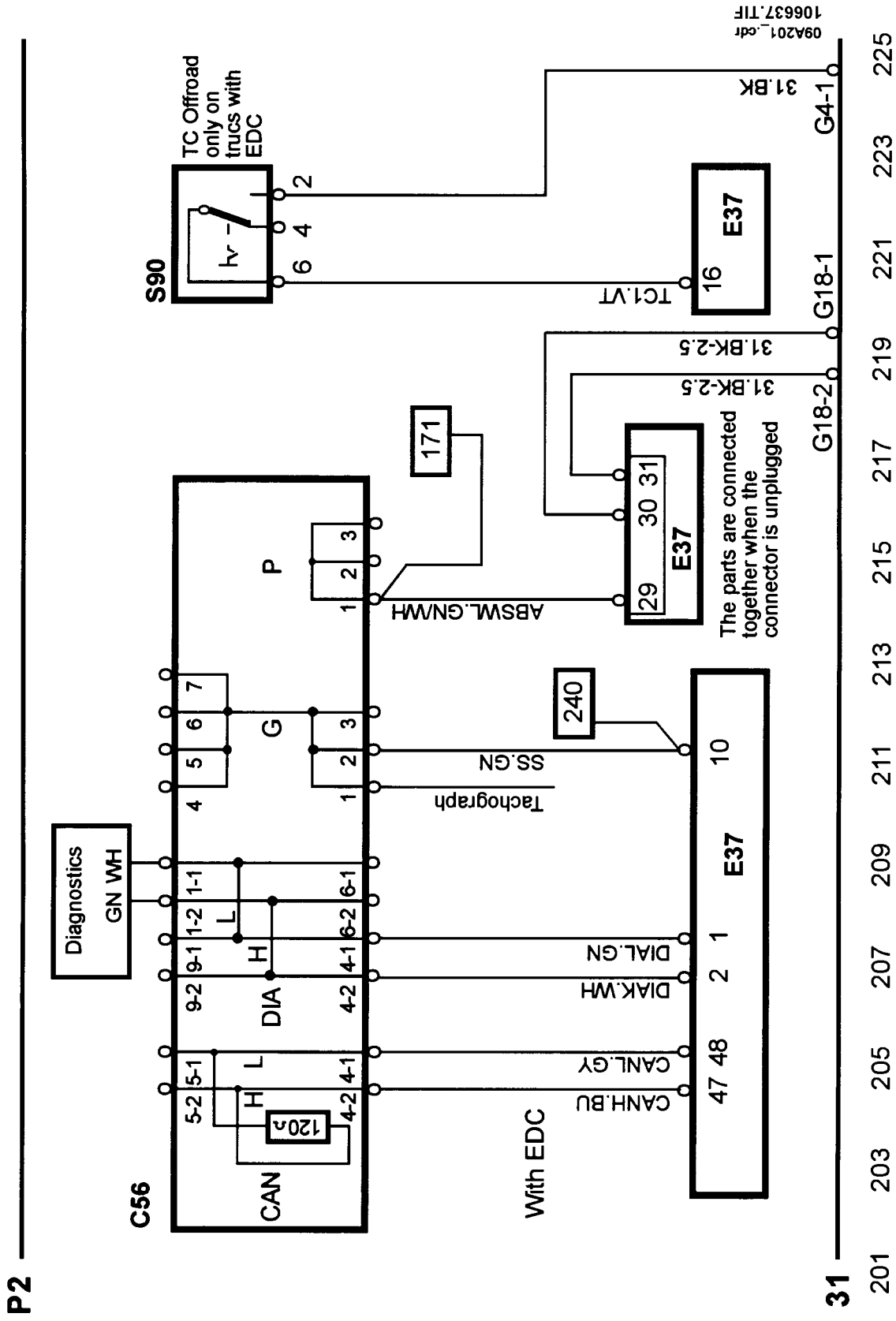

P2

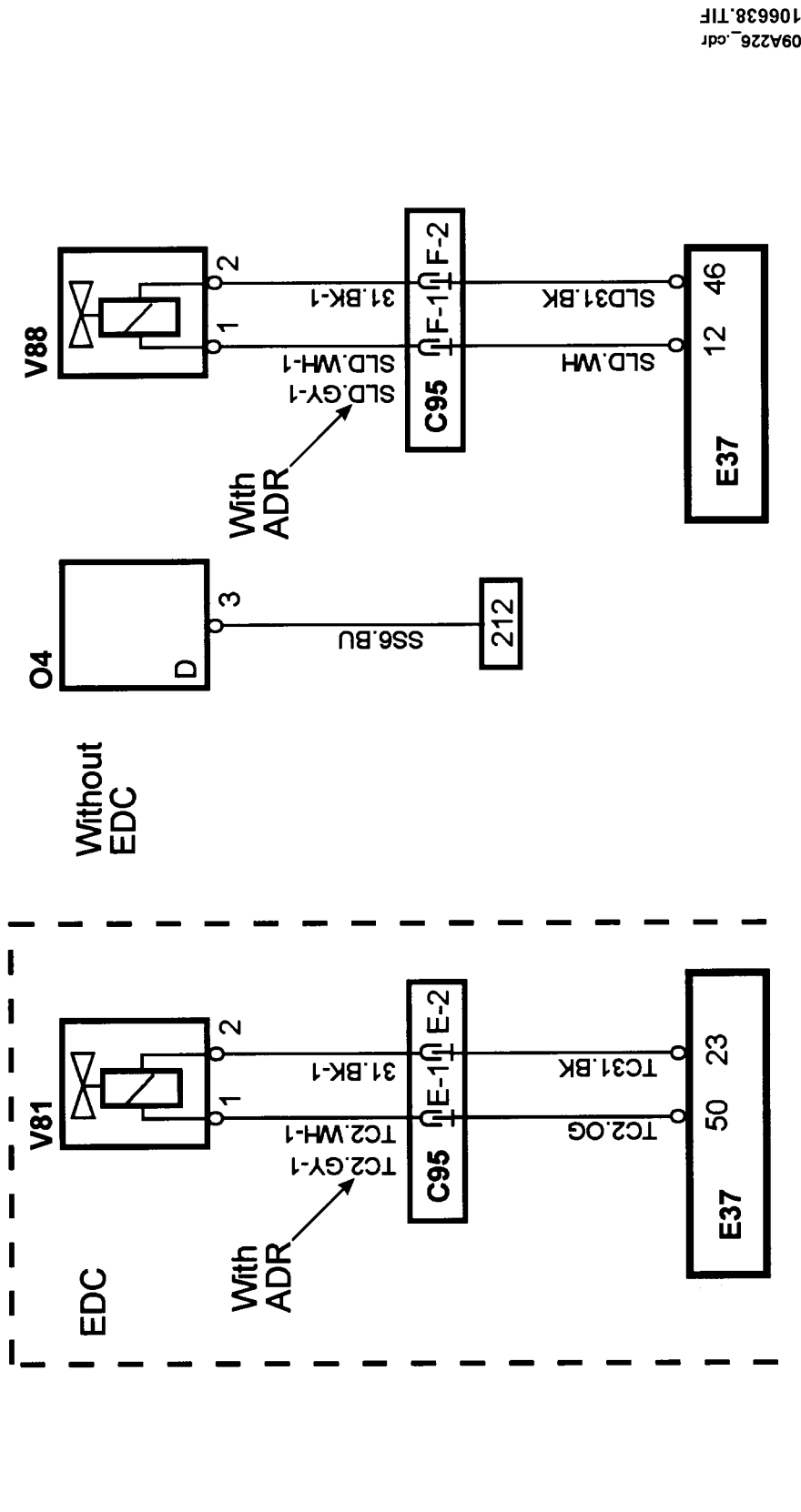

09A226_cdr
106638.TIF

31

226 228 230 232 234 236 238 240 242 244 246 248 250

Input signals

The tables on this spread show which input signals the control unit can receive.

Input signals

Function	Source	Signal type	Pin
Gives vehicle speed	Tachograph/connector C56	Frequency	10
Activates TC Off Road program	Switch	Earthing (0V)	16
Shows wheel speed	Sensor beside right-hand rear wheel	Frequency	17, 18
Shows that brake light has been activated	Relay switch	+24 V	19
Shows wheel speed	Sensor beside left-hand front wheel	Frequency	20, 21
Shows wheel speed	Sensor beside right-hand front wheel	Frequency	39, 40
Shows wheel speed	Sensor beside left-hand rear wheel	Frequency	44, 45

Output signals

The table below shows which output signals the control unit can supply.

Output signals

Function	Destination	Signal type	Pin
Requests brake control	Control valve, pressure reduction left rear	+24V	7
Requests brake control	Control valve, maintaining pressure left rear	+24V	8
Shows ABS control	Connector C56	Earthing (0V)	11
Requests speed reduction	Proportional valve	PWM	12
Requests brake control	Control valve, lowering pressure right rear	+24V	25
Requests brake control	Control valve, maintaining pressure right rear	+24V	26
Lights lamp	ABS warning lamp via C56	Earthing (0V)	29
Requests brake control	Control valve, lowering pressure right front	+24V	33
Requests brake control	Control valve, maintaining pressure right front	+24V	34
Requests TC control	TC Solenoid valve	+24V	50
Requests brake control	Control valve, lowering pressure left front	+24V	54
Requests brake control	Control valve, maintaining pressure left front	+24V	55

Other connections

The table below shows the control unit connections for power supply, system earth, communications lines etc.

Function	Source or destination	Signal type	Pin
Communication	Diagnostic socket for PC	Data DIAL	1
Communication	Diagnostic socket for PC	Data DIAK	2
Activate/Erase fault code	Diagnostic switch	Earthing (0V)	3
Lights lamp	Diagnostic lamp		
Power supply in	Fuse number 18	+24V	5, 28, 38
Earthing control valves	Control valves, right front and left rear	Earthing (0V)	6
Earthing solenoid valve	TC Solenoid valve	Earthing (0V)	23
Earthing control valves	Control valves, left front and right rear	Earthing (0V)	27
Earthing control valves (internal connection in control unit from pins 6 and 27).	G18	Earthing (0V)	30, 31
Earthing control unit	G13	Earthing (0V)	43
Earthing actuator	Proportional valve	Earthing (0V)	46
Communication	Connector C56	Data CANH	47
Communication	Connector C56	Data CANL	48

Pin numbering

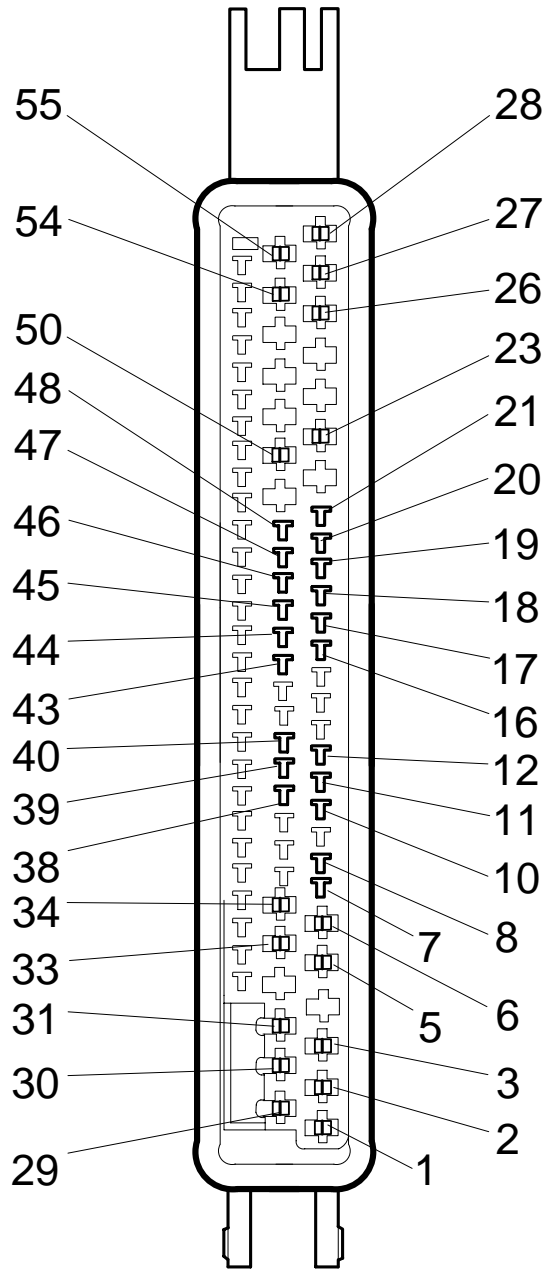

10_2449

cardiagn.com

Specifications

Component	Designation	Resistance, Ohm
R9	Brake reduction relay 6x2 with air suspension ASA700	265-345
T11/T12	Wheel sensor front, after May 1993	1100-1250
T13/T14	Wheel sensor rear, after February 1994	1575-1925
V3/V4/V5/V6	Control valve/in	14-21
V3/V4/V5/V6	Control valve/out	14-21
V7	Solenoid valve for brake reduction 6x2 with air suspension ASA700	54-63
V81	TC solenoid valve	54-63
V88	Proportional valve	18-30