

EBS

Function description

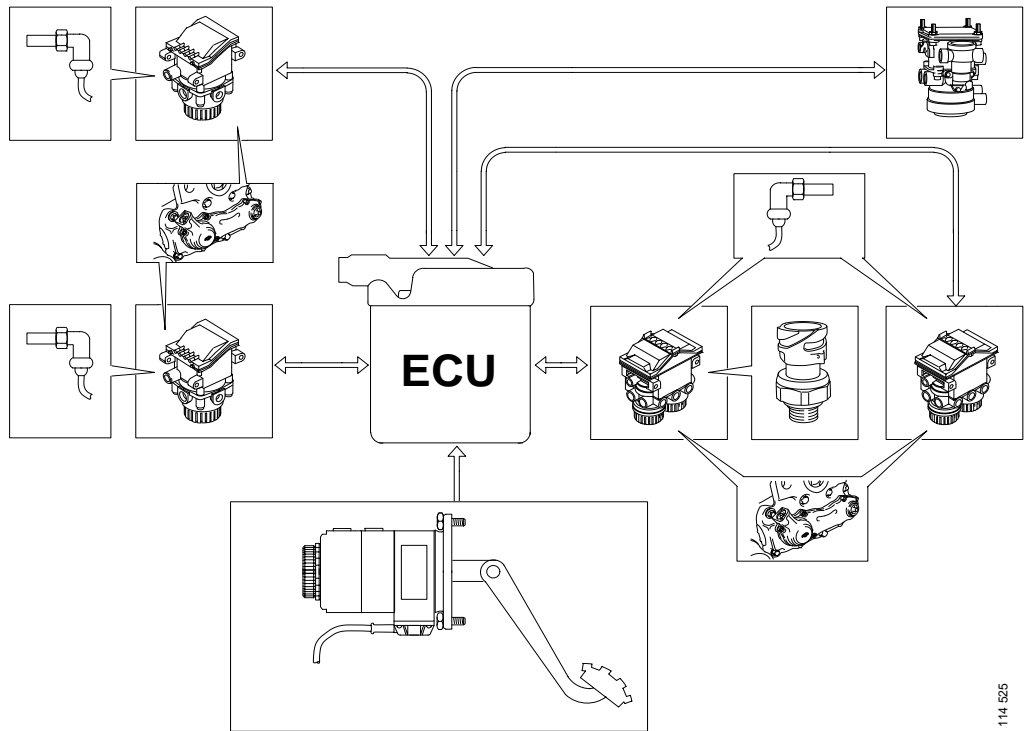

114 525

Contents

General	3
System description	Subsystems.....	4
	Structure of the system	6
	Working principles	8
	System signals.....	14
Description of components	Control unit EBS 2.0 / 2.1.....	18
	Control unit EBS 2.2.....	20
	Service brake valve	23
	Single control module.....	24
	Double control module	26
	Trailer control module	29
	Pressure sensor.....	32
	Other components	33
Interaction with other systems	37
Limit values for rolling circumference	39
Abbreviations	40

General

This version of the function description covers the EBS systems manufactured.

The EBS system differs from an ABS system in a number of aspects.

An ABS system merely controls braking if the wheels have locked or tend to lock. The ABS system then ensures that the wheels do not lock so as not to lose steering and to improve braking. Under normal braking, the driver activates the air to the brake cylinders via the service brake valve.

EBS controls the entire braking sequence, both applying and releasing of the brake. The system gauges how much braking the driver wants and then allows the control modules at the wheels to activate the air to the brake cylinders. This gives a shorter reaction time and consequently a shorter braking distance.

EBS 2.0 1996

- 4-channel system
- 4x2
- Tractor unit
- Front circuit reduction

EBS 2.1 1997

- 5-channel system
- Several configurations: 4x2, 6x2, 6x2*4 and 6x2/4
- Truck
- Improved diagnostics, the control module fault codes are stored in a control unit.
- Improved front circuit reduction

EBS 2.2 1999

- Double control module for drive axles
- CAN communication with auxiliary brake system
- Pressure sensor linked to the double control module which controls axle two.
- TCM Trailer Control Module
- Automatic Brake Adaptation, TBA
- New configurations, two drive axles with/without load transfer, and four-axle configurations.
- The auxiliary brake is load-dependent via the brake pedal

System description

Subsystems

The EBS system is made up of subsystems.

- EPB - Electro Pneumatic Brake system
- ABS - Antilock Braking System
- TC - Traction Control
- TBA - Automatic Trailer Brake Adaptation

These four systems form part of and make up the complete EBS system.

TC and TBA assume that the vehicle has EDC.

EPB

EPB is responsible for electronic brake pressure control. This is also backed up by a pneumatic brake system if the electrical circuit stops working.

ABS

If the wheels tend to lock, the system receives information on this and releases the brake pressure which is present out to the brake cylinders. This is pulsed so that a different part of the tyre is always against the road surface. If the driver has braked using the retarder, this will also be switched off during control.

TC

In the event of wheelspin, the control unit in the vehicle will send signals to the control unit of the control modules so that these brake the wheels which have lost traction. If two wheels lose traction, the engine will receive information on throttle-back.

TBA

TBA calculates the pressure required for the trailer so that it starts braking at the same time as the tractor unit and brakes its own weight. This always ensures optimal trailer braking. This function is available only when the vehicle is fitted with a trailer control module and TBA is active.

Braking characteristics of the system

This system is built to ensure even wear over the brake pads as a result of light braking. Frequent braking of this kind is responsible for pad wear.

In the event of harder braking, the distribution of the braking is utilised in order to provide the most optimal friction per axle.

When the pedal is depressed fully, the system activates full pressure.

The structure of the system

A central control unit 1 communicates with control modules 2 and 3 and trailer control module 8 via CAN cables. At the same time, the control unit 1 communicates with a control unit on the trailer.

Single control module 2 and double control module 3 communicate with the control unit and activate the brake pressure to the brake cylinders as required by the control unit 1. However, the double control module controls one or two drive axles. Vehicles with a tag axle have a single control module which controls both wheels on the tag axle. The control modules contain a control unit, solenoid valves and pressure sensors.

Service brake valve 5 is essentially a standard service brake valve with an additional part which contains two potentiometers. This provides the control unit with an electric reference value.

ABS sensor 4 senses the speed of the wheels. Each wheel is fitted with a sensor.

Wear sensor 6 is located on the brake calliper adjusting device. This sensor measures the overall wear of the brake pads and brake discs. Pad wear wires are also fitted to the brake pads in vehicles manufactured before 010699.

Pressure sensor 7 senses the weight of the vehicle by measuring the pressure in the air bellows for the suspension on the drive axle (axle 2).

The trailer control module 8 regulates the control pressure to the trailer. It receives the required brake pressure from the control unit 1, adjusts this depending on the trailer and activates the correct brake pressure.

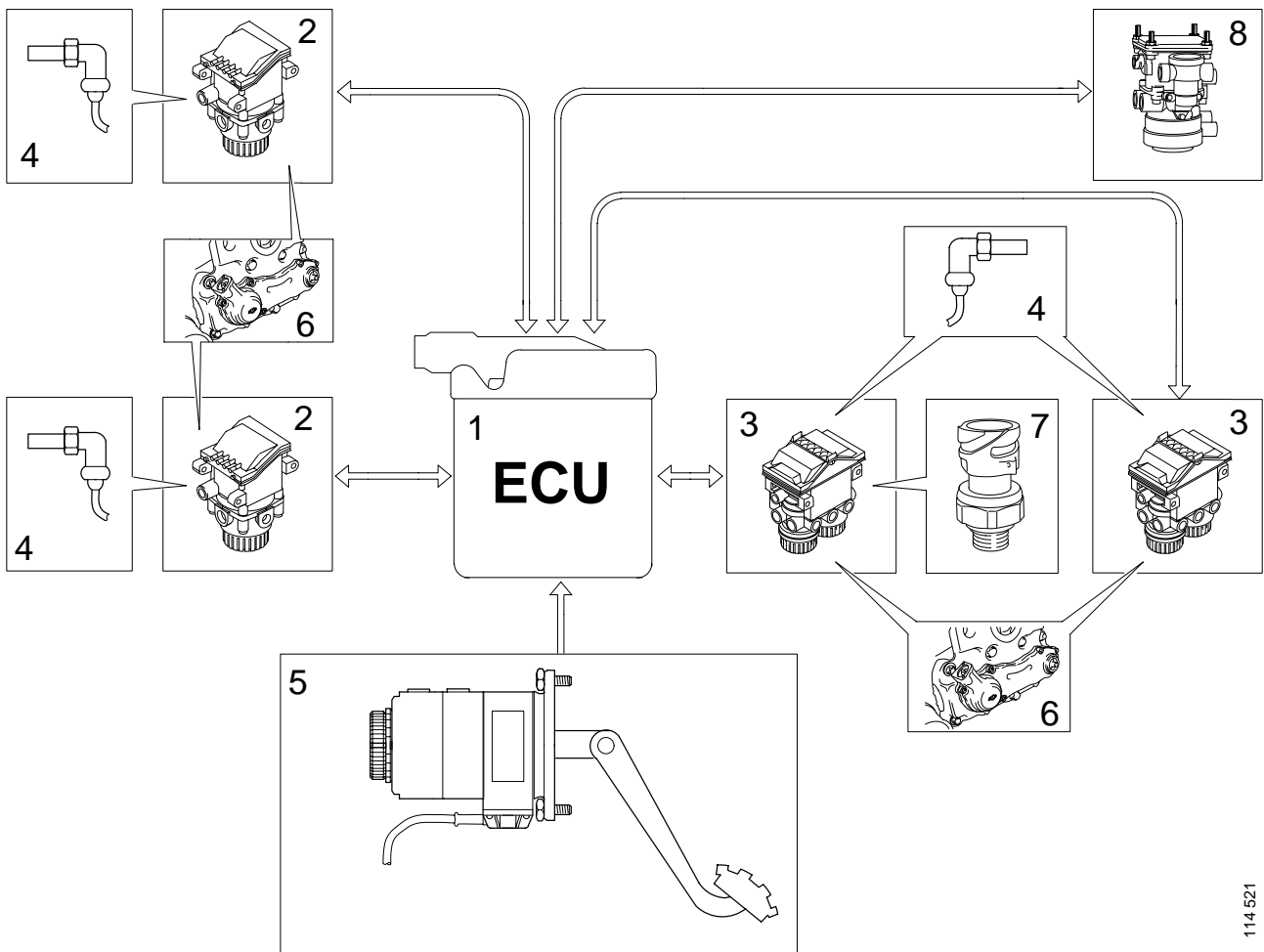

114 521

cardiagn.com

EBS 2.2 6x4 with 6-channel system

- 1 Control unit*
- 2 Single control module*
- 3 Double control module*
- 4 ABS sensor*

- 5 Service brake valve*
- 6 Wear sensor*
- 7 Pressure sensor*
- 8 Trailer control module*

Working principles

Backup braking

There are two backup circuits in the vehicle. These operate independently of electrical signals. These circuits are actuated by the regular service brake valve and are connected directly to the control modules. In the event of electronically controlled braking, the air in the backup circuit is kept back at the control modules by means of a solenoid valve. The pressure from the service brake valve also passes to the trailer relay valve or the trailer control module if the vehicle is fitted with one of these.

The backup system brakes the vehicle:

- when the power is turned off
- if the control unit switches off one or more control modules on account of a serious fault occurring in the system.

The control modules are without power when the backup system takes over. The air from the service brake valve passes into the control valve, which now operates as a relay valve. This makes braking proportional to the travel of the foot pedal.

Braking with the aid of electronics

When the starter voltage is switched on, the service brake valve 4 sends an electrical signal to the control unit 1 in the cab when activated.

The pressure sensor 5 is connected to the double control module 3 in EBS 2.2. CAN communication is used to transmit the signal to the control unit 1 in the cab. In EBS 2.0 / EBS 2.1, the signal is switched directly to the control unit. The control unit, together with the signal from the service brake valve and the pressure sensor, calculates the brake pressure value to be activated by the control modules 2 and 3. These then automatically adjust the brake pressure to the brake cylinders C. The control modules 2 and 3 contain a pressure sensor which measures the brake pressure. If the correct brake pressure is not attained, the system switches to backup position on the axle where brake pressure is not being attained.

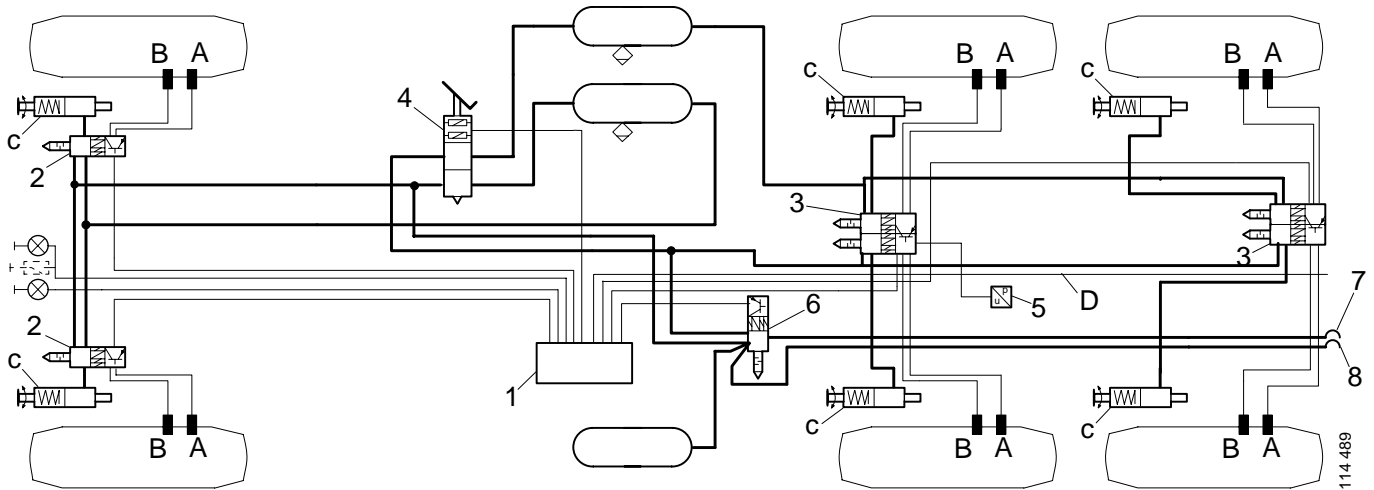

6x4 with 6-channel system. EBS 2.2

- | | |
|---------------------------|--------------------------------|
| 1. Control unit | 7. Trailer socket, control air |
| 2. Control module | 8. Trailer socket, feed air |
| 3. Axle module | A. ABS sensor |
| 4. Service brake valve | B. Wear sensor |
| 5. Pressure sensor | C. Brake cylinder |
| 6. Trailer control module | D. CAN cable to trailer |

Vehicle with trailer control module

CAN communication is used by the control unit to send a signal to the trailer control module 6, which adjusts this signal and outputs the pressure to the trailer socket 7 for control air. If the trailer has EBS, the CAN signal to the trailer is used. This signal is sent via the 7-pole trailer contact. This signal is used as a reference value by the trailer's control unit.

Vehicle without trailer control module

If the trailer has EBS, the CAN signal to the trailer is used. This signal is sent via the 7-pole trailer contact. This signal is used as a reference value by the trailer's control unit.

In the case of trailers without EBS, the service brake valve sends an air signal to the trailer relay valve, which activates pressure to the trailer's control line.

Braking in combination with retarder

During braking, only the retarder is braked over the first part of the pedal travel. EBS controls the braking torque to the retarder. This takes place by means of CAN communication.

The braking torque of the retarder is load-dependent.

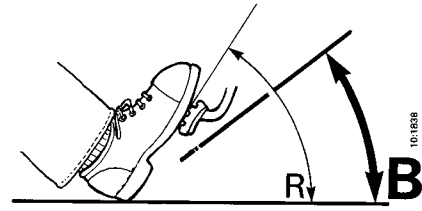

R = Retarder only

B = Both retarder and wheel brake

The switch C (AUT) on the dashboard must be activated.

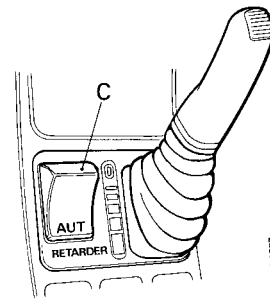

ABS in the system

The wheel sensors are connected to their respective control modules. The signal is passed on via the EBS system's own CAN bus to the control unit, where the vehicle's reference speed is calculated.

ABS control

When a wheel exhibits a tendency to lock, its control module reduces the pressure. The wheels can thus be braked within permissible slip values. See Functional description, ABS/TC 10:04-01.

ABS and retarder braking

During braking using the retarder, the retarder influences the drive wheels only. If the vehicle is light, the drive wheels can lock. This is prevented by the EBS, which switches off the retarder.

In EBS 2.0/2.1, the retarder is disengaged by means of the DBR relay.

EBS 2.2 stops and requests the braking torque from the retarder by means of CAN communication.

TC, Traction Control

If one or more drive wheels start to lose traction, the electronics detect this and can thus either reduce the engine torque or brake the wheel which has lost traction. When drive wheels lose traction, the system uses the speed of the front wheels as a reference.

TC is fitted only on vehicles with EDC.

TC - engine control

Engine control is active at all speeds and comes into play when both wheels spin at the same speed. It is also used when a wheel spins and the speed of the vehicle is in excess of 40 km/h.

A CAN signal is sent to the EDC control unit requesting a reduction in engine speed.

The slip limit can be increased slightly if the driver actuates the TC-OFF ROAD switch.

This function can be disabled in order to be able to drive a vehicle which has TC in a power tester. To do this, depress the diagnostics switch for at least 5 seconds. The power tester status is indicated by the flashing of the diagnostics lamp. The TC lamp will also flash.

TC – brake control

If only one drive wheel has lost traction, this wheel is braked by means of brake pressure. The wheel is controlled by the brake pressure sensor and the wheel sensor. The brake pressure to the brake cylinder reduces the rate of rotation of the wheel, which means that the driving force is transferred to the wheel which has not lost traction. This process synchronises the speed of the drive wheels.

Brake control is active only at speeds of less than 40 km/h. If it is active and the vehicle is accelerated to a speed greater than 40 km/h, it continues to operate until the next change of gear.

If there is too little brake pressure in any of the circuits, the TC brake control will be deactivated after 1 second.

Front circuit reduction

Vehicles with an axle distance <3700 mm and a 4x2 configuration have front circuit reduction.

When the vehicle is being driven unloaded, the system reduces the brake pressure on the front axle in order to maintain the axle pressure on the rear axle and thereby also to maintain the directional stability of the vehicle.

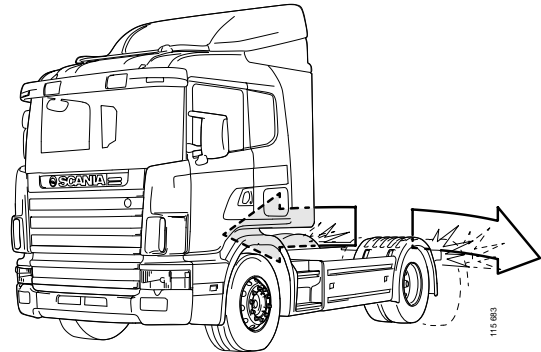

Automatic Trailer Brake Adaptation, TBA

Vehicles fitted with a trailer control module have Automatic Trailer Brake Adaptation, TBA (EBS 2.2).

It can be difficult to adjust the braking of a vehicle which tows different types of trailer.

The TBA function receives the required pressure from the EBS control unit.

TBA calculates the pressure required for the trailer so that it starts braking at the same time as the tractor unit and brakes its own weight. TBA equalises the vehicle's pad wear and increases its stability under braking.

TBA makes a rough calculation after the vehicle has braked 3 - 5 times. Rough brake adaptation is implemented on the basis of this calculation. When the vehicle has braked 10 times, the TBA has calculated the brake application pressure of the trailer. Adaptation takes place gradually every time the vehicle is subsequently braked.

TBA depends on information from EDC and Retarder. Correct brake adaptation assumes that EDC and Retarder are operating correctly.

TBA is not active at speeds below 10 km/h and under braking where the activated brake pressure is greater than 6.5 bar.

System signals

Signals to and from control unit

The illustration to the right shows an EBS system on a three-axle vehicle with a 6-channel system.

- 1 TC lamp. This should come on when the ignition switch is set to the drive position and go out after 3 seconds. This lamp flashes when TC OFF-ROAD is switched on.
- 2 ABS warning lamp for the vehicle. This comes on when the ignition is turned on for three seconds. Provided that the system is fault-free. This lamp comes on when any signal has ceased to operate. If this lamp comes on, EEB also receives information indicating that ABS is non-operational.
- 3 The low air pressure warning lamp is activated when the starting voltage is activated for 3 seconds. This lamp flashes if any of the control modules switches into backup position. This lamp flashes when the air pressure is low. The low air pressure buzzer sounds at the same time.
- 4 The EBS control unit reads the pressure sensor signal in the parking circuit. This signal is used only when a trailer control module is fitted to the vehicle.
- 5 The diagnostics button and lamp are fitted so that flash codes can be read and erased (the same signal as the TC lamp).
- 6 The brake pad wear lamp comes on when the overall width of the brake disc and brake pad is less than 68 mm. In vehicles manufactured prior to 1 June 1999, this lamp also comes on when the wires in the pads break. The pad wear lamp comes on if the pad wear differs by more than 25 % between the right and the left wheel on one and the same axle. This lamp will also come on in the event of a fault in the circuit.
- 7 This control unit emits a signal to the DBR relay during ABS control.
- 8 PC containing the Scania Diagnos and Scania Programmer software.
- 9 The trailer control module regulates the control pressure to the trailer. The trailer control module is electronic and automatically adjusts the braking of the trailer to that of the tractor unit.
- 10 The double control module regulates the brake pressure to the drive axles. This is also a "collecting point" for signals from wheel sensors, wear sensors and pressure sensors. These signals are then sent to the control unit by means of CAN communication.

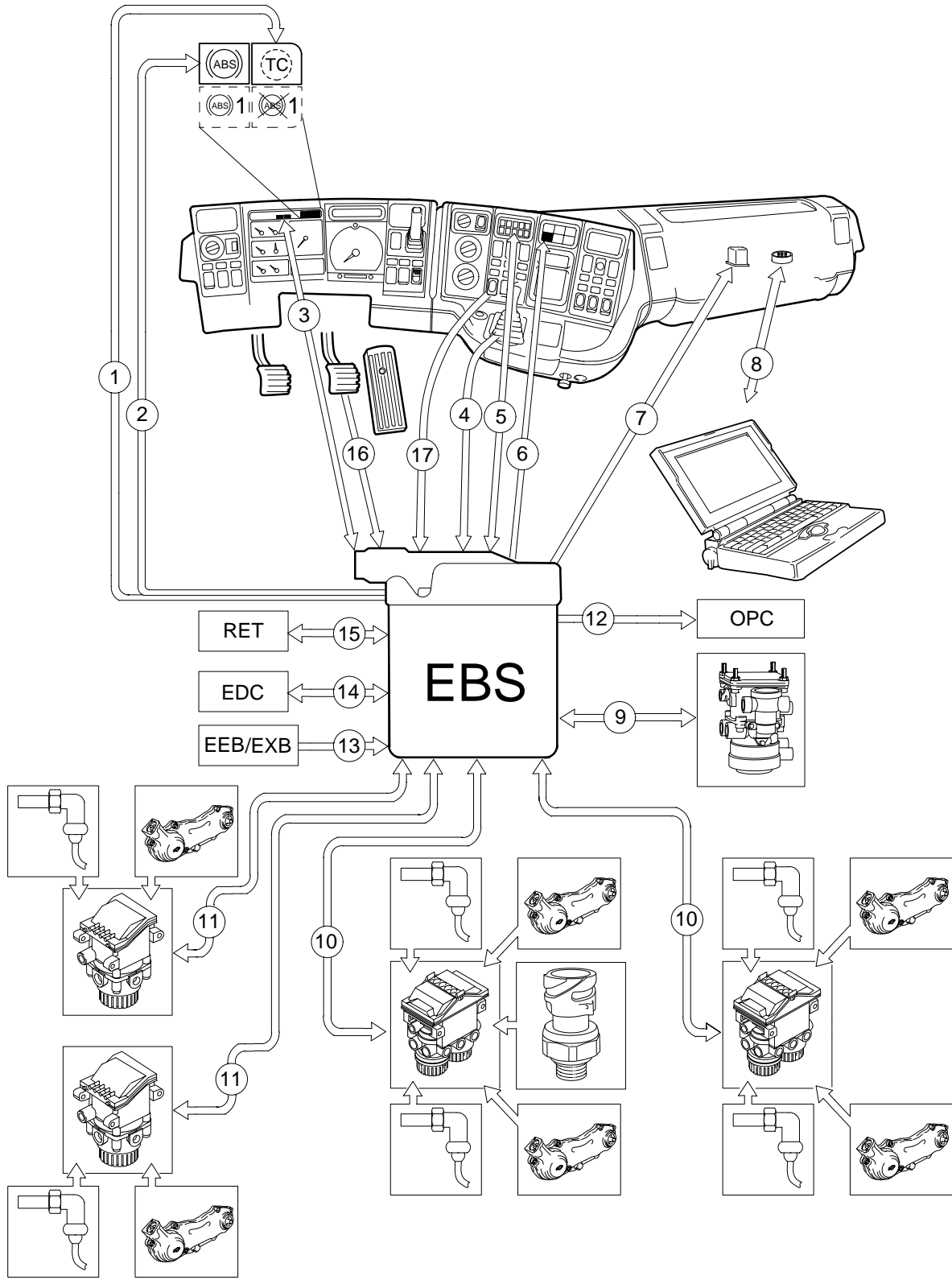

cardiagn.com

114 647

- 11 Single control modules regulate the brake pressure to one or two wheels, or to one axle (6x2 tag axle). This is also a "collecting point" for signals from wheel sensors and wear sensors. These signals are then sent to the control unit by means of CAN communication.
- 12 The Opticruise control unit communicates with EBS, and this information is one-way. EBS indicates ABS control. EBS also forwards the wheel speed signals to Opticruise.
- 13 Exhaust brake control unit. This signal is one-way. The exhaust brake sends a signal indicating that it has been activated.
- 14 The EDC control unit has two-way communication with EBS. EBS requests throttle-back during TC control. EDC provides information on the current engine torque and amount of fuel being injected.
- 15 The retarder control unit is connected to EBS by means of CAN communication. EBS requests the braking torque from the retarder. EBS provides information on ABS control.
- 16 The brake pedal's potentiometers provide the control unit with a signal indicating the braking torque requested by the driver.
- 17 TC OFF-ROAD is used so as to be able to increase wheelspin, such as when driving under muddy conditions.

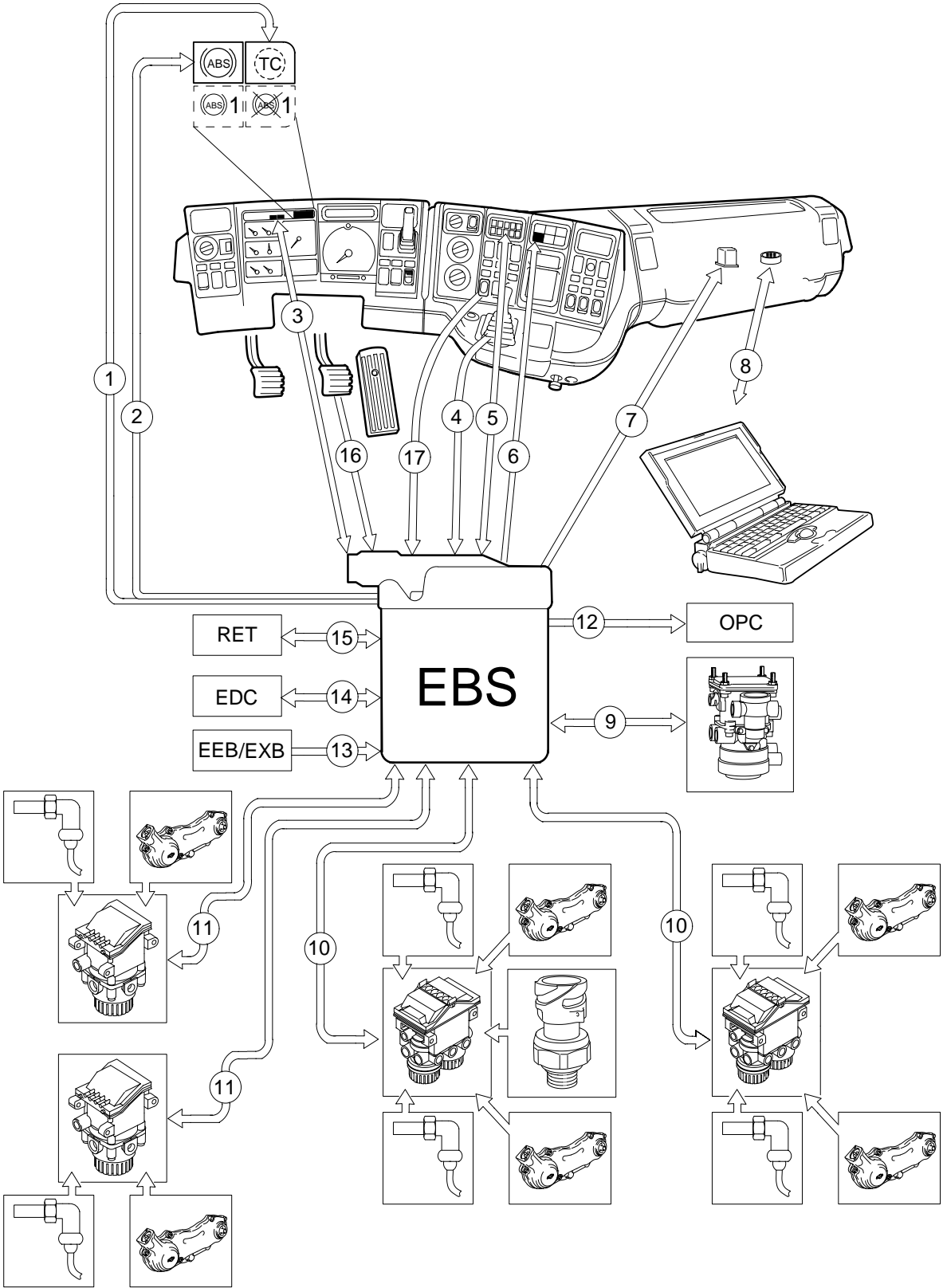

cardiagn.com

114 647

Description of components

Control unit EBS 2.0/2.1

Connections EBS 2.0/2.1

This control unit has a 55-pole coupling head. EBS 2.0 and 2.1 have control units which look identical. The software, on the other hand, is different.

The difference between these is that EBS 2.1 has improved fault diagnostics. Fault codes which affect control modules in EBS 2.0 are understood from the control modules. From EBS 2.1, these fault codes are stored in the control unit.

IMPORTANT! When the tyre size is changed, or if the vehicle is modified and changes configuration, the control unit must be reprogrammed.

The control unit's connector

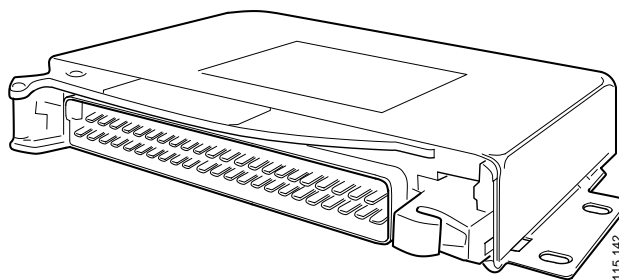
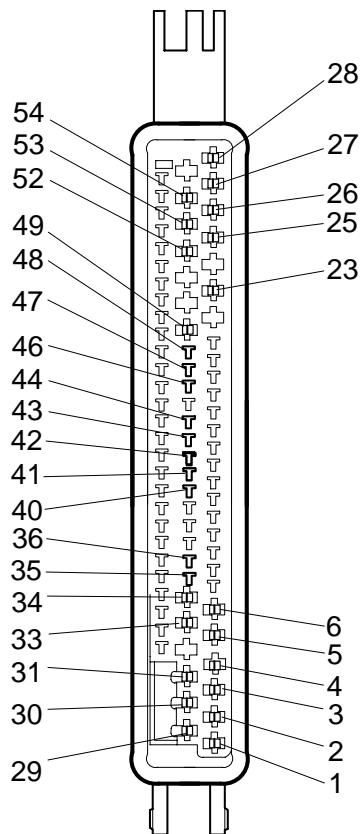

Connections

Not used	55	28	System voltage (30-supply)
System voltage for control module D	54	27	System voltage for control module A
System voltage for control module E	53	26	System voltage for control module B
System voltage for control module F	52	25	System voltage for control module C
Not used	51	24	Not used
Not used	50	23*	TC information lamp
TC switch	49*	22	Not used
CAN H for trailer	48	21	Not used
CAN L for trailer	47	20	Not used
CAN H for vehicle	46	19	Not used
Not used	45	18	Not used
CAN L for vehicle	44	17	Not used
CAN H for control modules	43	16	Not used
CAN L for control modules	42	15	Not used
DIA K	41	14	Not used
DIA L	40	13	Not used
Not used	39	12	Not used
Not used	38	11	Not used
Not used	37	10	Not used
Earth for control modules	36	9	Not used
Analogue signal from service brake valve to retarder	35	8	Not used
5 V supply to analogue sensors	34	7	Not used
Load-sensing pressure sensor	33	6	Signal SM 2 from service brake valve
Not used	32	5	Signal SM 1 from service brake valve
System earth	31	4	Earth for analogue signals
Low air pressure warning lamp	30*	3*	Pad wear lamp
Vehicle ABS lamp	29*	2	DBR relay
		1	Power supply (15 V)

The symbol "" after a pin number indicates that the signal is activated when the circuit is earthed.*

Control unit EBS 2.2

Connections EBS 2.2

The control unit has 4 connectors. These are divided into function groups.

IMPORTANT! When the tyre size is changed, or if the vehicle is modified and changes configuration, the control unit must be reprogrammed.

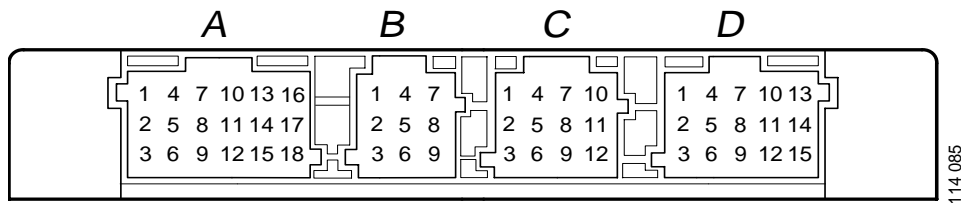
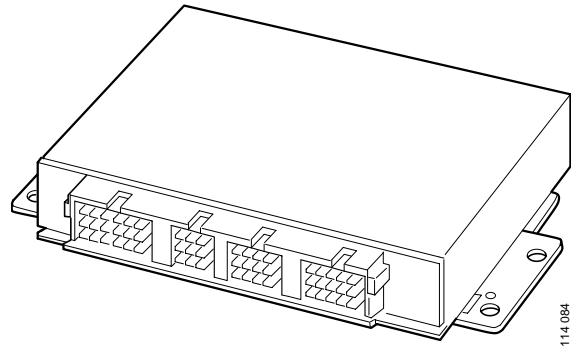

Connector A has pin connections which touch internal components in the cab, along with general component connections which are not dependent on the configuration.

Connector B supplies power to analogue components such as pressure sensors and the service brake valve potentiometer. The signals from the service brake valve potentiometers can also be found here.

Connector C is connected to the control modules which provide the braking function of the front axle.

Connector D is connected to the control modules of the rear axles. The trailer control module is also linked to this connection. The control unit has a total of 54 terminals, but not all of these are used.

The tables below show which signals the control unit can receive and which pins are used for each respective signal.

The symbol "" after a pin number indicates that the signal is activated when the circuit is earthed.*

Connector A

A1	CAN L communication	A10	System earth
A2		A11*	TC information lamp
A3	CAN H communication	A12	Earth for control modules
A4		A13	DIA K
A5		A14	DIA L
A6*	TC switch	A15	
A7	System voltage (15-supply)	A16	DBR Signal
A8	System voltage (30-supply)	A17*	Vehicle ABS lamp
A9*	Pad wear lamp	A18*	Low air pressure warning lamp

Connector B

B1		B6	Signal from pressure switch in parking circuit
B2	5 V supply to service brake valve	B7	Signal SM 1 from service brake valve
B3	Earth for service brake valve	B8	
B4	Signal SM 2 from service brake valve	B9	Signal from exhaust brake
B5			

Connector C

C1	Earth for control module A (left side axle 1)	C7	
C2	Earth for control module A (right side axle 1)	C8	CAN H control module A
C3		C9	CAN H control module B
C4	CAN L control module A	C10	
C5	CAN L control module B	C11	System voltage for control module A
C6	Earth for control module A (left side axle 1)	C12	System voltage for control module B

Connector D

D1	CAN L trailer	D9	CAN L trailer control module
D2	Earth for control module, axle 3	D10	CAN H control module C-D, axle 2
D3	CAN H trailer	D11	CAN H control module E, axle 3
D4	Earth for control module C, axle 2	D12	CAN H trailer control module
D5		D13	System voltage for control module C, axle 2
D6	Earth for trailer control module	D14	System voltage for control module E, axle 3
D7	CAN L control module C, axle 2	D15	System voltage for trailer control module
D8	CAN L control module E, axle 3		

Service brake valve

Service brake valve potentiometer function

The service brake valve has two electrical potentiometers. These are activated along with the ordinary pneumatic control when the pedal is depressed. The potentiometers are electrically connected to the EBS control unit. The signals from these are mutually opposed.

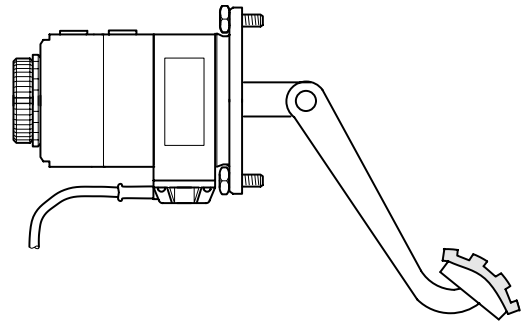

The signals from the potentiometers are designated SM 1 and SM 2. The value from the signal SM1 increases and the value from signal SM2 decreases as the pedal is depressed. The signals are processed in the EBS control unit so as to be able to calculate the correct braking value for the trailer and control modules.

IMPORTANT! The service brake valve is factory-calibrated. On the valve is a label showing a specific number which has to be keyed in when reprogramming takes place. This applies to EBS 2.2.

EBS 2.0/2.1 is calibrated using Scania Programmer.

Recalibration must be carried out if the control unit has been reprogrammed or the service brake valve has been replaced.

Other pneumatic functions are described in booklet 10:02-03, Front and rear circuits, components.

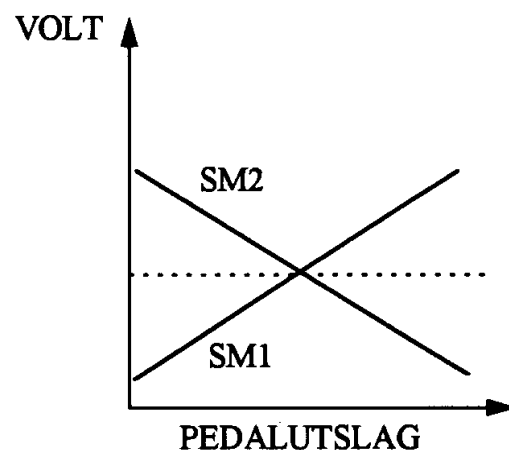

Single control module

Function of the control module

The control module is a complete valve which is controlled by means of electronic signals. In the event of a fault in the electronics, there is a pneumatic backup circuit which is activated and implements braking.

The control module contains solenoid valves for the backup function, pressure increase, pressure decrease and a pressure sensor.

IMPORTANT! Single control modules have been replaced on rear drive axles with a double control module from 011199 (EBS 2.2).

The upper part consists of a terminal block connected to an electronic unit.

The control module also acts as a "collecting point" for ABS sensors and wear sensors. These signals are then sent from the control module on to the EBS control unit by means of CAN communication.

Electronic braking

The solenoid valve for the backup system is powered up under braking. This prevents the control air from the service brake valve from braking the vehicle. Instead, the control module's control unit activates the pressure increase valve, which releases the correct air pressure in pulses to the relay valve function in the control module. The brake pressure value is measured while in the pressure sensor. The control module receives from the EBS control unit a request as to which brake pressure value is to brake the vehicle.

When the brake pressure is reduced, the pressure decrease valve is activated, which reduces the pressure in pulses.

Backup braking

Backup braking takes place when a serious fault has occurred.

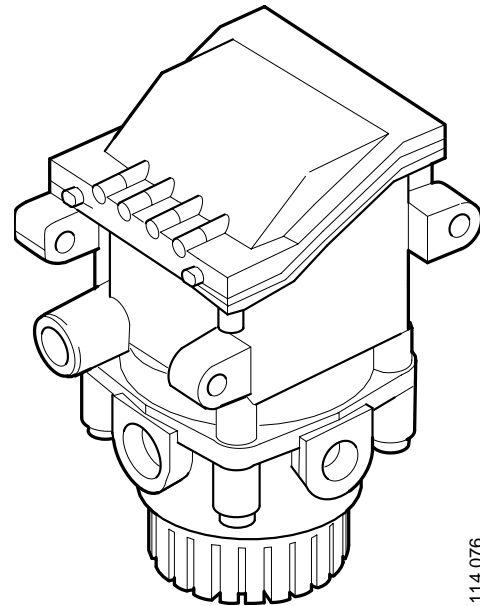

114 076

The solenoid valve for the backup system is not powered up. This makes the solenoid valve open and allows it to release the control pressure from the service brake valve. This pressure then opens the relay valve function in the control module.

The backup function is activated axle by axle.

Electrical connections

- DF A = Wheel sensor
- DF B = Wheel sensor
- BVS = Wear sensor, brake pads
- Pin 1. Earth
- Pin 2. Signal from sensor
- Pin 3. Signal from sensor
- Pin 4. Power supply to sensors
- CAN+ & Umo = CAN communication and power supply to the control module
- Pin 1. Earth for control module
- Pin 2. Power supply to control module
- Pin 3. CAN H.
- Pin 4. CAN L

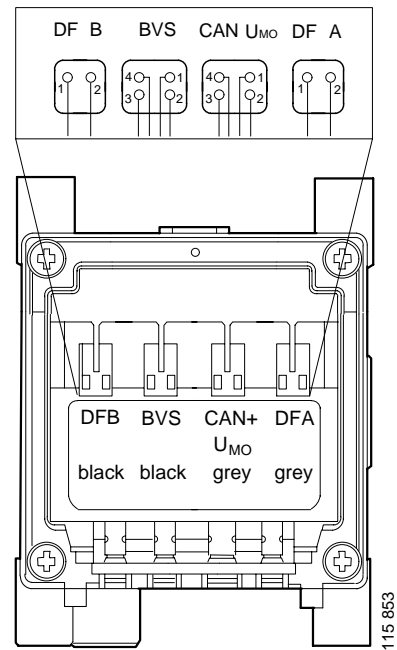

Air connections

1. Supply
2. Control out
3. Venting
4. Control in

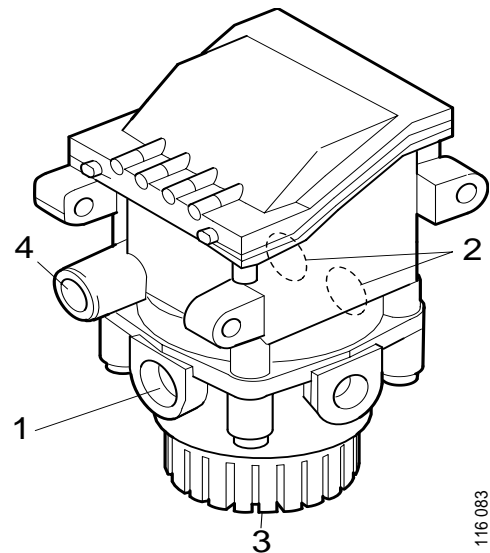

Double control module

Control module function

The double control module is used on drive axles.

This control module is a complete valve which is controlled by means of electronic signals. In the event of a fault in the electronics, there is a pneumatic backup circuit which is activated and implements braking.

Double control modules control two or four wheels.

The control module contains solenoid valves for the backup function, pressure increase, pressure decrease and pressure sensors.

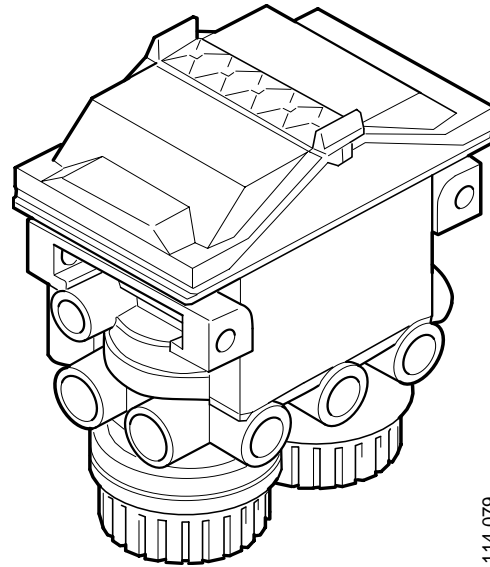

114 079

The upper part consists of a terminal block connected to an electronic unit.

The control module also acts as a "collecting point" for ABS sensors and wear sensors. These signals are then sent from the control module to the EBS control unit by means of CAN communication.

Electronic braking

The solenoid valves for the backup system are powered up under braking. This prevents the control air from the service brake valve from braking the vehicle. Instead, the control module's control unit activates the pressure increase valve, which releases the correct air pressure in pulses to the relay valve function in the control module. The brake pressure value is measured while in the pressure sensors. The control module receives from the EBS control unit a request as to which brake pressure value is to brake the vehicle.

When the brake pressure is reduced, the pressure decrease valve is activated, which reduces the pressure in pulses.

Backup braking

Backup braking takes place when the control module is unable to attain the correct brake pressure value.

The solenoid valves for the backup system are not powered up. This makes the solenoid valves open and allows them to release the control pressure from the service brake valve. This pressure then opens the relay valve function in the control module.

The backup function is activated axle by axle.

Electrical connections

DF A =	Wheel sensor
DF B =	Wheel sensor
DF C =	Wheel sensor
DF D =	Wheel sensor
BVS 1/3 =	Wear sensors, brake pads
Pin 1.	Earth
Pin 2.	Signal from sensor
Pin 3.	Signal from sensor
Pin 4.	Power supply to sensors
BVS 2/4 =	Wear sensors, brake pads
Pin 1.	Earth
Pin 2.	Signal from sensor
Pin 3.	Signal from sensor
Pin 4.	Power supply to sensors
ALB 1/2 =	Pressure sensor
Pin 1.	Earth
Pin 2.	Signal from pressure sensor
Pin 3.	Not used
Pin 4.	Power supply to sensors

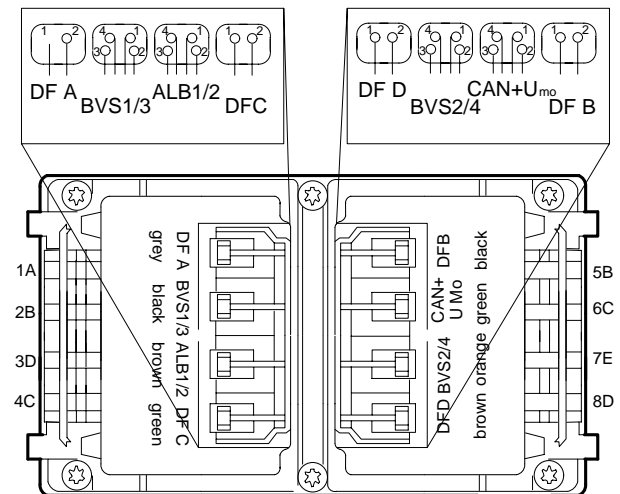

CAN+ & Umo = CAN communication and power supply to the control module

Pin 1.	Earth for control module
Pin 2.	Power supply to control module
Pin 3.	CAN H
Pin 4.	CAN L

cardiagn.com

Air connections

- 1 Supply in
- 21 Control out
- 22 Control out
- 3 Venting
- 4 Control in

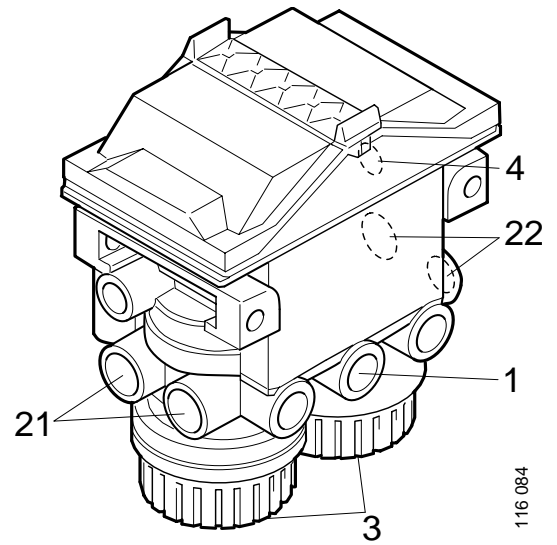

116 084

Trailer control module

The trailer control module is a complete valve which is controlled by means of electronic signals. In the event of a fault, there is a backup circuit which is activated and implements braking.

Trailer control module function

The trailer control module ensures that the control pressure to the trailer is correct. It also balances the pressure so that the brake adaptation between the trailer and the vehicle is correct.

The parking brake operates in the same way as in a conventional system.

The EBS control unit sends signals to the trailer control module by means of CAN communication.

Vehicles fitted with a trailer control module have Automatic Trailer Brake Adaptation (TBA).

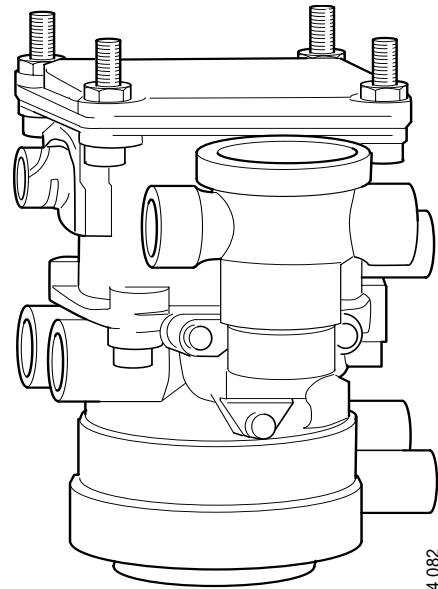

114.082

Trailer control module

Electronic braking

The supply pressure passes via the trailer control module - which has a rapid emptying function (regarding this function, see booklet 10:05-05, trailer brake circuit, components) - to a relay valve.

The control pressure which comes from the service brake valve's rear and front circuit function is impeded by the backup valve, which is activated under electronic braking.

The pressure increase solenoid valve releases the amount of air required in order to attain the correct brake pressure to the control line and out to the trailer. This is measured using the pressure sensor.

The pressure decrease valve drains out the air in pulses.

The trailer control module adjusts the control pressure out to the trailer so that each part of the vehicle combination brakes its own weight.

If the vehicle is fitted with automatic brake adaptation, the trailer control module will adapt the brake pressure so that there is no pushing or pulling force in the coupling bar between the tractor unit and the trailer.

Backup

The backup function comes into operation when any serious fault occurs.

The pressure from the service brake valve travels via the backup valve, which is not powered up. This pressure then actuates the relay valve which is built into the trailer control module. This relay valve opens and releases control pressure to the trailer.

Electrical connections

- | | |
|---|----------------|
| 1 | Voltage supply |
| 2 | Earth |
| 3 | CAN H. |
| 4 | CAN L |

Air connections

- | | |
|----|---------------------------------|
| 1. | Supply in |
| 21 | Supply out |
| 22 | Control out |
| 3 | Vent |
| 41 | Control in from rear circuit |
| 42 | Control in from front circuit |
| 43 | Control in from parking circuit |

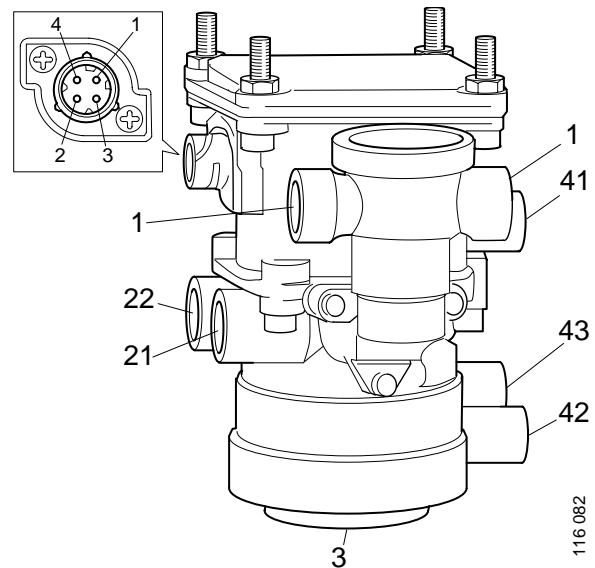

Load-sensing pressure sensor

Pressure sensor function

This pressure sensor is mounted on the drive axle air bellows.

This pressure sensor measures the pressure in the air bellows. The control unit uses this value together with the value from the service brake valve in order to calculate which brake pressure value is to be activated from the control modules.

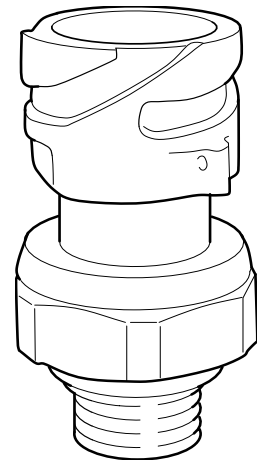

Pressure sensor

Note: Brake adaptation will not work if a pressure sensor is faulty.

- If the pressure sensor indicates a full load and the vehicle is unloaded, the directional stability of vehicles with front circuit reduction will be affected.
- The distribution of wear over the axles will be affected.
- The TBA function will be affected.
- Retarder integration will be affected.

Pin location in connection

- | | |
|---|------------------|
| 1 | 5 V power supply |
| 2 | Earth |
| 3 | Signal |

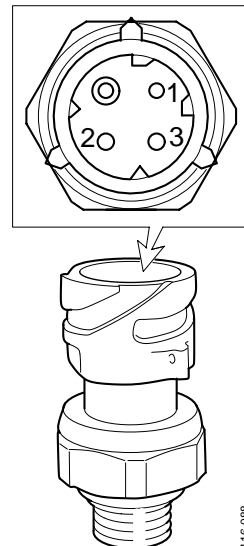

Other components

Brake pad wear sensors

These wear sensors are located on the brake callipers. These measure the overall wear on the brake discs and brake pads.

Electrical connections

- A. Earth
- B. Power supply
- C. Signal

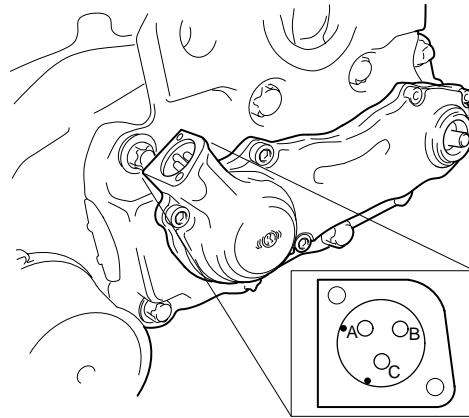

Pad wear wires

The wires in the pads snap if the pads become too worn. These wires are connected in series to the wear sensor.

Note: These wires are not included in vehicles from chassis numbers 1250601, 9042879 and 4413456

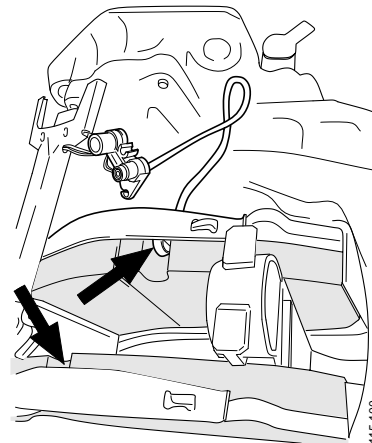

ABS sensor

This sensor is connected to the control modules, and information on the rate of rotation of the wheel is sent between the control modules and the EBS control unit by means of CAN communication.

There are two types of sensor, one straight and one angled.

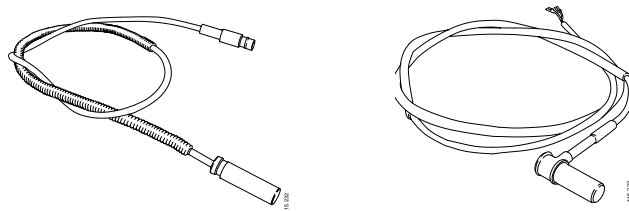

The inductive sensor essentially comprises a permanent magnet with a coil and a round pole pin. When the toothed wheel rotates, the magnetic flow in the coil is converted to alternating voltage, the frequency of which is proportional to the rate of rotation of the wheel.

This alternating voltage is then converted to digital signals in the control unit.

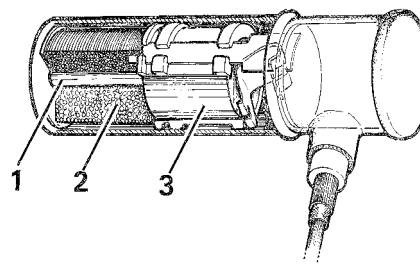

- 1 Pole pin
- 2 Coil
- 3 Permanent magnet

Low air pressure warning lamp

A red warning lamp which comes on when the ignition switch is set to the drive position and goes out after about 3 seconds. The low air pressure buzzer sounds at the same time. This lamp flashes when a serious fault has occurred, and if the system pressure is too low.



ABS warning lamp, vehicle

A yellow vehicle warning lamp which comes on when the ignition switch is set to the drive position and goes out after about 3 seconds or at a speed of 5-7 km/h if the vehicle system is fault-free. If a fault occurs, the lamp comes on immediately or at a speed of 5-7 km/h. This lamp stays on up to a speed of 20 km/h when a fault has been erased. This applies only when there has been a wheel speed input signal fault.

This lamp comes on in the event of a CAN fault between EBS and EDC, along with Retarder (EBS 2.2).

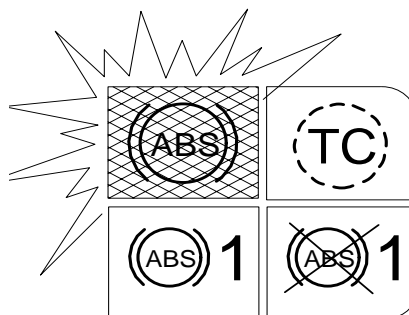

TC control lamp

The information lamp and warning lamp for the TC system are one and the same. It should come on when the ignition switch is set to the drive position and go out after 3 seconds. The TC lamp also comes on when:

- brake control or engine control is active.
- a fault occurs in the CAN circuit between EBS and EDC. This applies to EBS 2.0/2.1.

If TC Off-Road is engaged with the TC Off switch, the TC lamp flashes for as long as the switch is set to Off-Road.

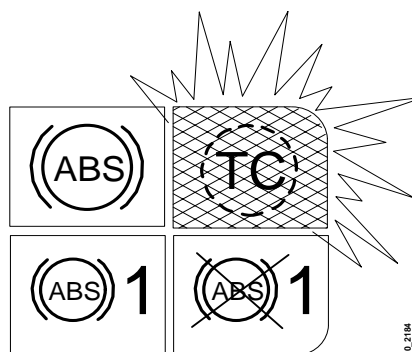

Pad wear information lamp

A yellow information lamp comes on when the total width of the brake disc and brake pad is less than 68 mm.

If the wear wires in the pad snap, this lamp comes on.

This lamp comes on if pad wear differs by more than 25 % between the right and the left wheel on one and the same axle.

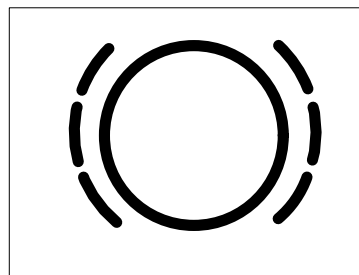

Interaction with other systems

CAN communication

The vehicle contains a number of systems which communicate with one another.

This communication takes place by means of CAN communication, which is based on digital transfer.

The EBS system works with three CAN circuits:

- CAN
- CAN BRAKE
- CAN TRAILER

CAN communicates with other electronic systems in the vehicle.

CAN BRAKE communicates with the control modules on the vehicle.

CAN TRAILER communicates with the trailer control unit.

Communication with the EDC control unit

EBS communicates with EDC by means of CAN communication. The information between the control units is two-way.

A request for throttle-back during TC is sent from EBS.

EBS receives information on throttle-back from EDC.

Communication with Opticruise

EBS communicates with Opticruise by means of CAN communication. The information between the control units is one-way.

EBS is connected to Opticruise, which receives information on ABS/TC control and wheel speeds.

Communication between Opticruise and EBS is used to confirm the correctness of the choice of an appropriate gear.

Communication with the auxiliary brake system

EBS communicates with the auxiliary brake system by means of CAN communication. The information between the control units is two-way (applies only to EBS 2.2).

EBS requests the braking torque from the retarder's control unit.

EBS provides information on ABS control to the retarder. This causes the retarder to be switched off. EBS also provides information on ABS faults.

Communication with EEB/EXB

EBS communicates with the exhaust brake by means of an analogue signal.

EBS receives information from EEB/EXB regarding the fact that the exhaust brake has been activated.

This signal is used by Automatic Trailer Brake Adaptation, TBA.

Limit values for rolling circumference

In vehicles with EBS, too great a difference between the rolling circumference of the front and rear wheels can result in erroneous signals to the control unit, with longer braking distances as a result. Use the values of the tyre's rolling circumference given by the manufacture and choose tyres so that the difference is no greater than

+ 12.0 % if the front wheels are larger than the rear wheels

-6,0 % if the front wheels are smaller than the rear wheels

$$\text{Difference (\%)} = \frac{\text{Front rolling circumference} - \text{Rear rolling circumference}}{\text{Rolling circumference, front}} \times 100$$

Example

Tyre, front axle: 315/80R 22.5
Rolling circumference: 3329 mm

Tyre, rear axle: 12R 22.5
Rolling circumference: 3360

$$\text{Difference (\%)} = \frac{3329 - 3360}{3329} \times 100 = -0.9\%$$

This difference is permissible, as this may be down to -6.0 %.

IMPORTANT!

- Minimum rolling circumference 2700 mm
- Maximum rolling circumference 3895 mm

Abbreviations

ABS	Antilock Braking System
EBS	Elektronic Brake System
EEB	Electronic Exhaust Brake
EDC	Electronic Diesel Control
EPB	Electronic Pneumatic Brake system
EXB	Exhaust Brake
CAN	Controller Area Network
OPC	Opticruise
TC	Traction Control
RET	Retarder
TBA	Trailer Brake Adaptation
TCM	Trailer Control Module