

SCANIA

10:04-05

Issue 1 en

Wabco ABS/TC "D" 4 and 6 circuit systems

Work description

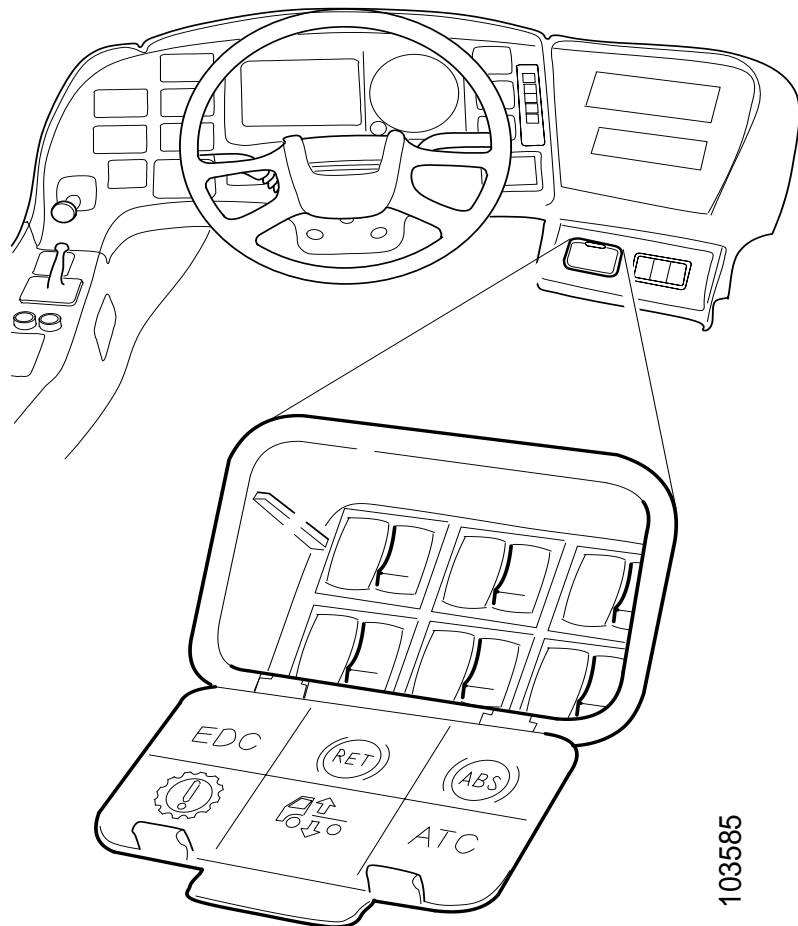

103585

cardiagn.com

Contents

General	3
	New features	3
Scania Diagnos, ABS/TC	Diagnostics panel	5
	Diagnostics mode	5
	System mode	8
Trouble shooting	Testing using a multimeter	11
	How to conduct fault diagnosis	11
	Fault codes	12
Electrical system	Wiring diagrams	17
	Associated diagrams in group 16	18
	Colour codes for electrical wiring	18
	Component locations	19
	Wiring diagrams	20
	Input signals	25
	Output signals	26
	Other connections	28
	Pin numbering on control unit	29
Specifications	30

General

This Wabco ABS/TC system has a new generation of control unit which is different from the previous one. The main differences are TC control with CAN communication to the EDC control unit.

All the differences compared with the previous generation of Wabco ABS are dealt with under the heading “New features”.

New features

The electrical differences in this version of Wabco ABS/TC compared with the previous version are as follows:

- TC control with engine and brake control are now optional. Exchange of information with the EDC control unit is via CAN/PWM communication.

Continued on next page >

- After turning the starter switch to drive, the control unit conducts a test and activates the control valves (a clicking noise is heard)
- The supply relays (R31 and R32) for wheel diagonals have been discontinued. These relays are now integrated in the control unit.
- When the starter switch is turned to the drive position the bus ABS warning lamp should go out after about 3 seconds, provided that there are no faults in the ABS.
- The ABS warning lamp shows whether there was a fault in the wheel sensors the last time the power was switched on. In order for the warning lamp to go out after the wheel sensors have been repaired, the start speed for all wheel sensors must be correct.
- ABS warning lamp relay (R34) is no longer fitted. When the ABS/TC control unit is removed, the ABS warning lamp is now lit by a circuit breaker, located in the connector for the control unit.
- When the starter switch is turned to drive, the TC indicator lamp/diagnostics lamp should go out after about 3 seconds (at the same time as the bus ABS warning lamp) if there are no faults in the TC system. The TC indicator lamp/diagnostics lamp goes out after about 1.5 seconds if the control unit is not configured for TC. For other functions of the TC indicator lamp, see the description of operation for ABS/TC.
- The control unit is automatically configured for TC when the starter switch is turned to the drive position, if that the system is not already configured for TC. This happens provided that that the control unit can make contact with the EDC/proportional valve and the TC valve.
- Function-specific connectors (five) to the control unit: Connector A contains connections for power supply, diagnostics and features on the instrument panel. Other connectors are mainly designed for components located on the chassis frame with associated cable harnesses.

- Information exchange with other control units in the vehicle is via CAN or PWM communication.

Mechanical differences compared with previously:

- The TC solenoid valve is new together with a double check valve. The solenoid valve is normally closed.

For a more detailed description, see the ABS/TC description of operation.

Scania Diagnos, ABS/TC

Diagnostics panel

This version of the Wabco ABS/TC has an integrated fault diagnosis system. The diagnostic panel is located on the instrument panel and consists of a switch for activating and erasing the diagnostics memory, as well as a diagnostics lamp for flashing codes. If the TC indicator lamp is fitted, this is connected in parallel with the diagnostics lamp.

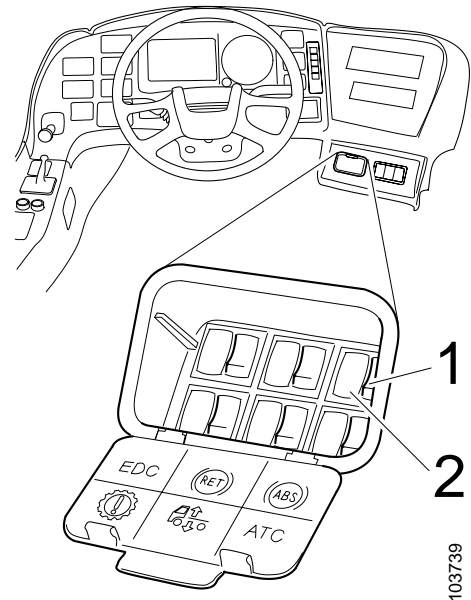

Diagnostics mode

Two things can be shown in diagnostics mode:

- 1 Fault code for the particular fault, if the system has one (see "AF" on page 7). In order for other faults to be displayed, the current fault must be repaired. The vehicle can have only 1 current fault code.
- 2 Fault codes for the faults which have been stored in the fault code memory (see "F1", "F2" and "F3" on page 7). Of these fault codes, the latest four are flashed out in reverse order, i.e. the latest registered code is shown first. There can be a maximum of 16 stored fault codes.

Note: The content of the text for codes which are flashed out and for codes which are read using Scania Diagnos varies.

Continued on next page >

1 Diagnostics switch ABS/TC

2 Diagnostics lamp

Displaying fault codes

In order for the control unit to display the current fault code or the stored fault codes, the diagnostics switch (D in the following pages) must be pressed for 0.5 - 3.0 seconds (= diagnostics mode). Fault codes consist of two digits.

No fault exists/no fault codes stored

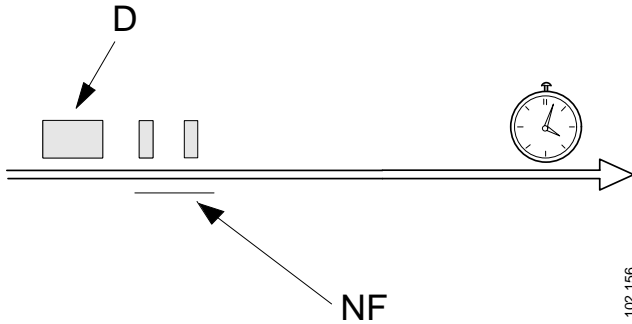

D = Diagnostics switch pressed for 0.5 - 3.0 seconds

NF = No fault exists/no fault codes stored. If there are no faults in the vehicle this flashing code is displayed once.

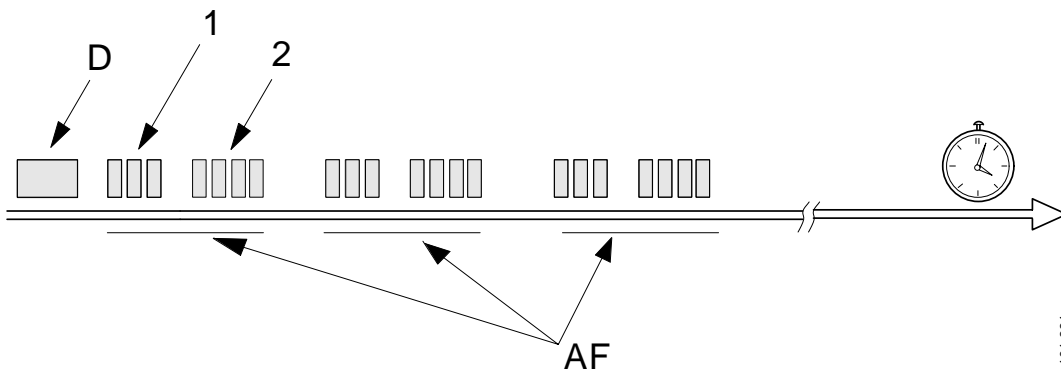
Current fault code

101 894

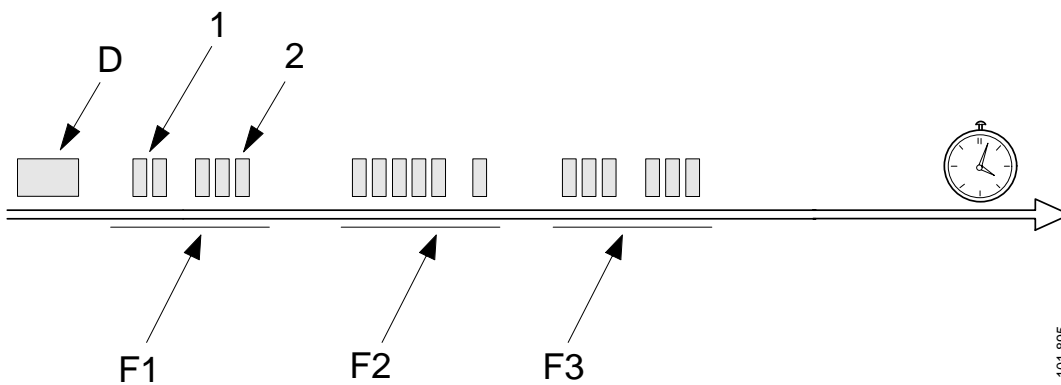
Stored fault codes (no current fault code exists)

101 895

D = Diagnostics switch pressed for 0.5 - 3.0 seconds

1 = 1st digit in fault code.

2 = 2nd digit in fault code.

AF = The control unit senses that there is a current fault present. Display of current fault code repeated. The vehicle can have only 1 current fault code.

F1 = 1st stored fault code

F2 = 2nd stored fault code

F3 = 3rd stored fault code

Comments about F1, F2 and F3: Stored fault codes are displayed once and there can be no more than 16 codes.

System mode

In order to set the control unit to system mode, the diagnostics switch must be pressed for 3 - 6 seconds.

In system mode:

- 1 Stored fault codes are erased. The erasure of stored fault codes is confirmed by the diagnostics lamp with eight quick flashes (see "C" on page 9). If there is a current fault code, this cannot be erased without the fault first being rectified.
- 2 The ABS/TC system's control unit is displayed. The control unit type is flashed out in the system block, which is repeated. One flash = 6x2 bus and two flashes = 4x2 bus. See "S" on page 9.
- 3 Engine control/speed limiter can be checked. If the diagnostics switch is pressed twice (the switch must be pressed for at least 0.5 seconds each time, but the interval between the two depressions must be no longer than 3.0 seconds), engine speed is reduced to idling for 10 seconds (the engine must be running at a speed of about 1000 rpm). Always wait until after the first system block before activating the diagnostics switch for reduce engine speed. See "DM" on page 10.
- 4 The TC/Retarder can be reconfigured. The control unit senses whether there is a TC valve, EDC/Proportional valve or DBR relay connected. The control unit is configured by pressing the diagnostics switch three times (the switch must be pressed for at least 0.5 seconds each time, but the interval between the presses must be no more than 3.0 seconds). The new configuration of the control unit is confirmed by the diagnostics lamp with four quick flashes. Always wait until after the first system block before activating the diagnostics switch to configure the control unit. See "DR" and "CR" on page 10.

The TC indicator lamp/diagnostics lamp lights for 3 seconds when the control unit is configured for TC when the starter switch is turned to drive and there are no faults in the TC system. The TC indicator lamp/diagnostics lamp lights for about 1.5 seconds if the control unit is not configured for TC, except when there is a fault in the TC system, when it lights continuously.

The control unit is automatically configured for TC when the starter switch is turned to drive, if the system is not already configured for TC. This happens provided that the control unit makes contact with the EDC/Proportional valve and the TC valve.

If the control unit is configured for ABS/TC, and it should be configured for ABS only, it must be configured manually as described on page 10 (see "DR" and "CR").

Display of system mode

For the control unit to be set to system mode, the diagnostics switch must be pressed for 3 - 6 seconds. The following is displayed/happens:

If there is a current fault code

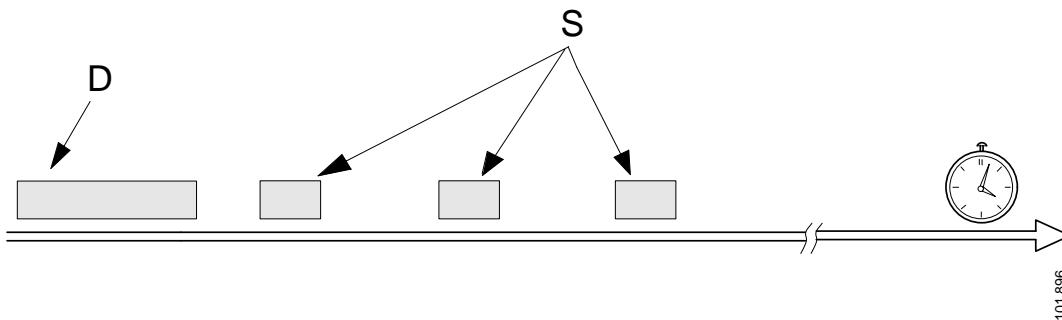

If no current fault code exists = erasure of stored fault codes

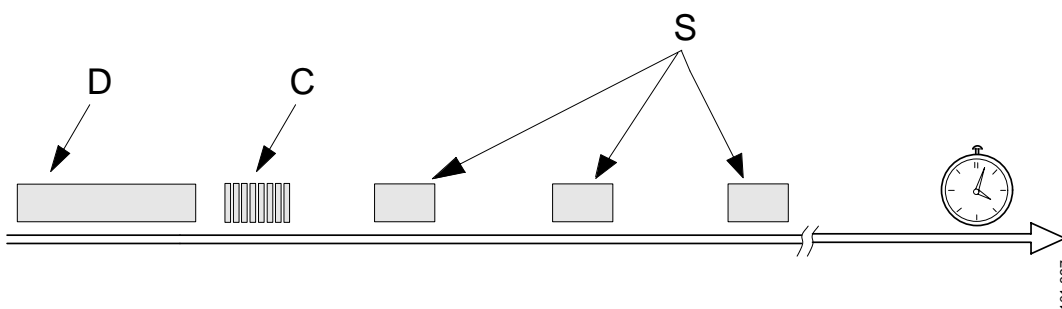

D = Diagnostics switch pressed 3 - 6 seconds

S = System block, flashed out as long as the control unit is in system mode:

One flash = 6x2 bus

Two flashes = 4x2 bus

C = Eight quick flashes, a confirmation that stored fault codes have been erased

Continued on next page >

Activating control unit functions in system mode

By pressing the diagnostics switch two more times after the first system block, you can check that engine control/speed limiter are working.

By pressing the diagnostics switch three times after the first system block, the TC/Retarder is reconfigured.

Checking engine control/speed limiter

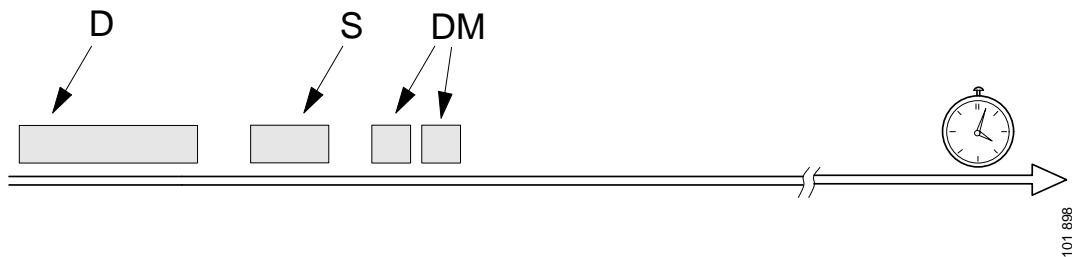

Configuring TC/Retarder

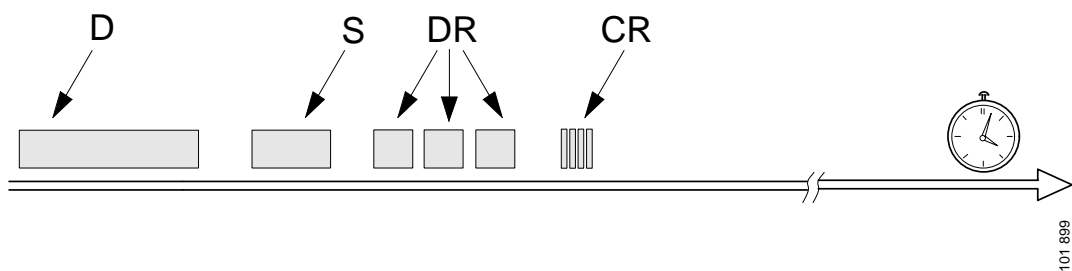

D = Diagnostics switch pressed 3 - 6 seconds.

S = System block: One flash = 6x2 bus
 Five flashes = 4x2 bus

DM = Diagnostics switch pressed twice after the first system block. The switch must be pressed for more than 0.5 seconds each time, but the interval between the presses must be no longer than 3.0 seconds. If the control unit has accepted your activation, engine speed is reduced to idling for 10 seconds (the engine must be running at about 1000 rpm).

DR = Diagnostics switch pressed three times after the first system block. The switch must be pressed for more than 0.5 seconds each time, but the interval between the presses must be no longer than 3.0 seconds.

CR = Four quick flashes, a confirmation that the control unit has been configured.

Trouble shooting

Testing using a multimeter

There is no Scania test instrument suitable for the five control unit connectors.

IMPORTANT!

Do not take readings on the pins in the control unit connectors, but take readings on the rear of the connector instead. Otherwise, there is a danger of damaging the pins in the connectors.

How to conduct fault diagnosis

- 1 Press the diagnostics switch for ABS/TC for between 0.5 - 3.0 seconds and read the flashing code, see pages 5 - 7. The current fault code or stored fault codes are then displayed. If there is a current fault code, this fault must be rectified before any stored fault codes are displayed.
- 2 Check that there are no faults as in the tables on pages 12 and 13.
- 3 If there is a fault, read the fault code text and read off the current circuit from the wiring diagrams. If you are unsure about the significance of the component designation, check this in the "Wiring diagrams manual".
- 4 Choose a suitable connector and take readings in and localise the connector using the components drawing. Do not take readings on the pins in the control unit connectors, but take readings on the rear of the connector instead.
- 5 Take readings using a multimeter and check the values on pages 25 - 30.

Fault codes

1st digit	Description	2nd digit	Description	Circuit
1	No fault	1	No fault	-
2	ABS modulating valve, open/short circuit	1	Right front	54
		2	Left front	29
		3	Right axle 2	37
		4	Left axle 2	62
		5	Right axle 3	46
		6	Left axle 3	71
3	Sensor, air gap too great	1	Right front	15
4	Sensor, Open/short circuit	2	Left front	3
5	Sensor, incorrect tyre/cross-connection/frequency too high	3	Right axle 2	7
6	Faulty pulse wheel, dirty/damaged	4	Left axle 2	19
		5	Right axle 3	10
		6	Left axle 3	23
7	System function	1	Open circuit, short circuit or faulty CAN/PWM/tachograph signal. Slip too great - roller brake tester.	114/ 109/ 105
		2	Open or short circuit, TC solenoid valve	74
		3	Open/short circuit, DBR signal	118
		4	ABS warning lamp blown. Check operation when power is switched on	90
		5	Open circuit in lead to proportional valve or disengaged TC feature due to a fault in TC solenoid valve/CAN communication.	102/ 74/ 114
		6	Open circuit or short circuit, proportional valve	102

Continued on next page >

1st digit	Description	2nd digit	Description	Circuit
8	Control unit	1	Voltage supply to diagonals too low, less than 18 volts	93/ 97
		2	Voltage supply to diagonals too high, greater than 30 volts	93/ 97
		3	Faulty supply relay/internal fault	-
		4	Faulty internal configuration	-
		5	Open circuit or short circuit in earth lead for one of the diagonals	121/ 122

Connection of wheel diagonals

The drawing below shows the numerical order of the axles on the various types of bus. The axles which are connected diagonally show the wheel diagonals, i.e. the wheels on the front and rear axles which are diagonally connected electrically to the ABS/TC control unit.

- Diagonal 1 = Right front/Left axle 2/Left axle 3
- Diagonal 2 = Left front/ Right axle 2/Right axle 3

For certain electrical faults in the ABS/TC system, only the faulty diagonal is disconnected.

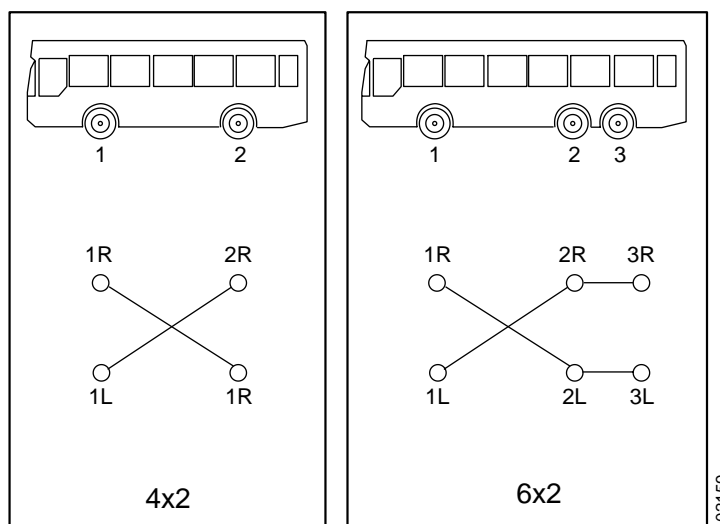

cardiagn.com

Generation of fault codes

Fault code for short circuit/open circuit can be generated after the power is switched on without the vehicle being driven. Other fault codes are generated based on a frequency change from the wheel sensors and the vehicle must therefore be driven.

When there is a short circuit to earth or to +24 volts, the faulty diagonal is disconnected. If there is an internal fault in the control unit, the system is entirely or partially disconnected.

The most common causes of generated fault codes for the wheel sensors are an excessively large air gap between the sensor and the pulse wheel or a broken/dirty pulse wheel.

Speed limiter

If top speed is set to 160 km/h, the speed limiter feature is disengaged. In vehicles with EDC, speed limitation is via the EDC system.

A fault in the speed signal from the tachograph is shown by the warning lamp and the TC lamp when speed is greater than 3 km/h. This fault is not revealed by the warning lamp if the vehicle is stationary. If a fault code has been generated for the tachograph speed signal, the signal from the wheel sensors is used for speed limitation.

CAN communication

CAN: Stands for controller area network. CAN communication is used to reduce the number of cables in the vehicle. This is intended to increase reliability.

CAN communication is in series. Vehicles with ABS/TC have a communications circuit which communicates with other control units via two cables, called CAN high (pin A-3) and CAN low (pin A-1).

In simple terms it can be said that CAN communication is similar to radio technology. The data signals which pass through a CAN lead can be compared to radio waves in the air.

When listening to the radio, the receiver is set so that one radio station is heard at one time. This is the only station that can be heard, despite the fact that there are many radio stations broadcasting at the same time.

A control unit does more or less the same thing with the data which comes through a CAN lead. For example, it listens for information from the EDC about engine torque, receives this value and uses it in calculations.

The control unit receives all CAN signals which are sent through the communications circuit in a special memory. This memory can be compared to several radio receivers which are switched on, but which are all set to different radio stations in order to listen to several particular radio programs at the same time. In this way, the control unit continuously senses what is happening.

This is nothing that the mechanic need to worry about. The only thing to remember is that it is not possible to check individual CAN signals using a multimeter.

Rolling circumference limits for front and rear wheels

In vehicles with ABS/TC an excessive difference between the rolling circumference of the front and rear wheels may give incorrect signals to the control unit resulting in longer braking distances. Use the values of tyre rolling circumference given by the manufacturer and choose tyres so that the difference is no greater than

- + 14.0 % if the front wheels are larger than the rear wheels.
- 14.0 % if the front wheels are smaller than the rear wheels.

$$\text{Difference (\%)} = \frac{\text{Front rolling circumference} - \text{Rear rolling circumference}}{\text{Front rolling circumference}} \times 100$$

Example:

Tyre, front axle: 315/80R 22.5
 Rolling circumference: 3329 mm

Tyre, rear axle: 12R 22.5
 Rolling circumference: 3360 mm

$$\text{Difference (\%)} = \frac{3329 - 3360}{3329} \times 100 = -0.9 \%$$

This difference is permitted as it may be up to -14.0 %.

Electrical system

Wiring diagrams

- The fault codes table earlier in this booklet refers to current paths.
- The wiring diagrams follow the component drawings. These have current path serial numbers. Use the references to the current circuits from the table for fault codes in order to find the correct diagram and the components in question.
- The diagrams use component name e.g. E37. The full name of the components is given in the "Wiring diagrams manual" in group 16 of the workshop manual.

Associated diagrams in group 16

Connection diagram

16:54-37

Colour codes for electrical wiring

BK	Black
BN	Brown
RD	Red
OG	Orange
YE	Yellow
GN	Green
BU	Blue
VT	Violet
GY	Grey
WH	White
PK	Pink

Component locations

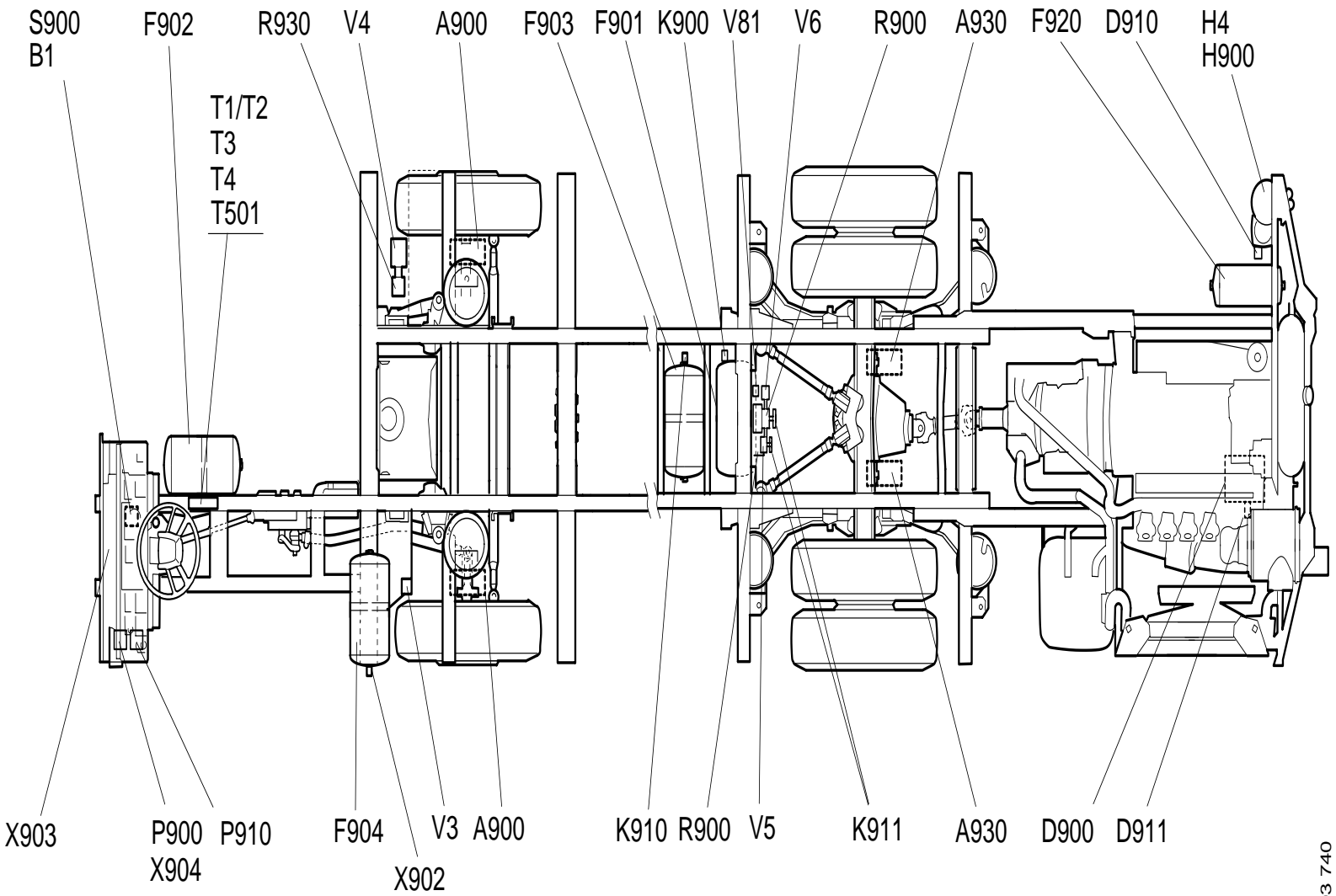

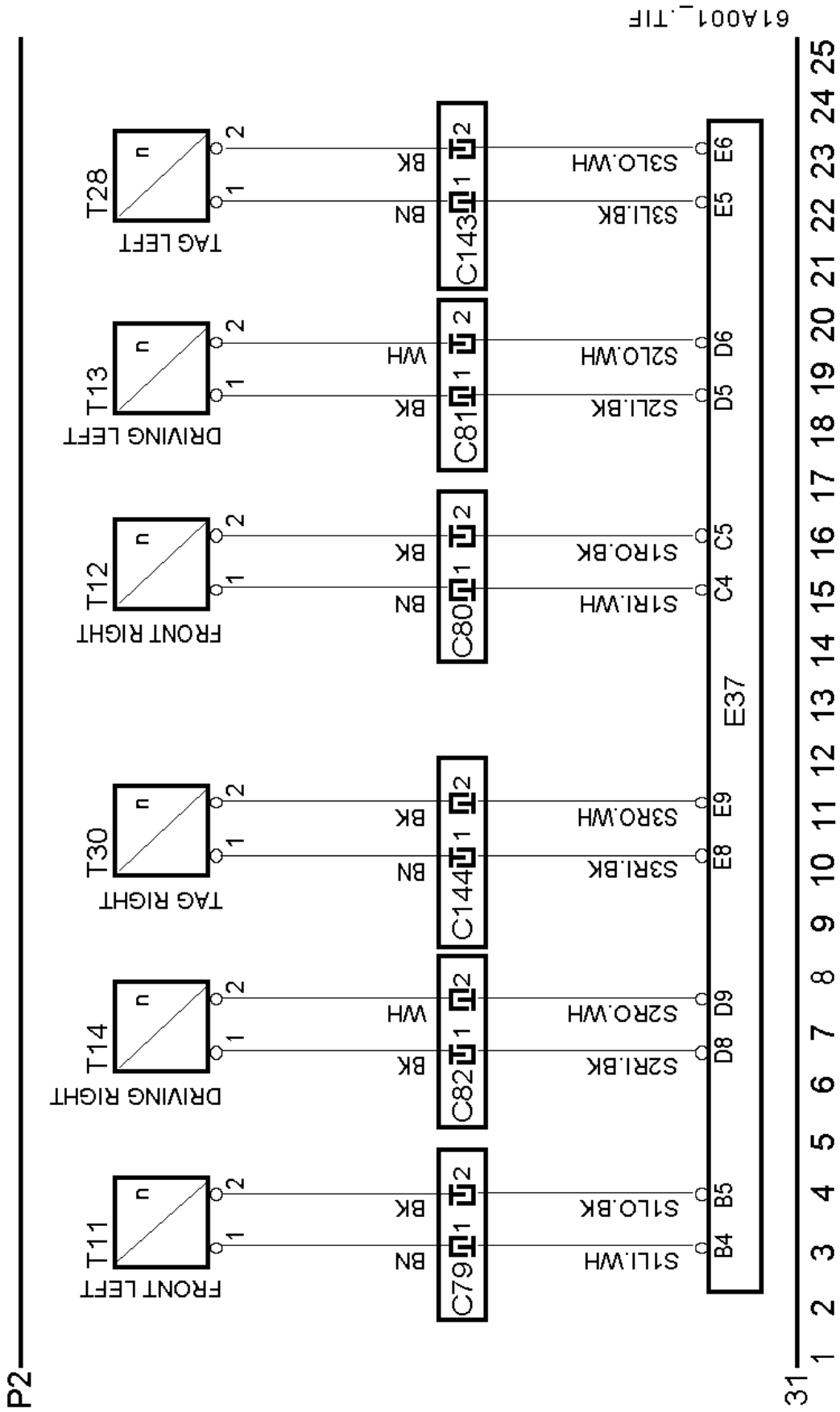

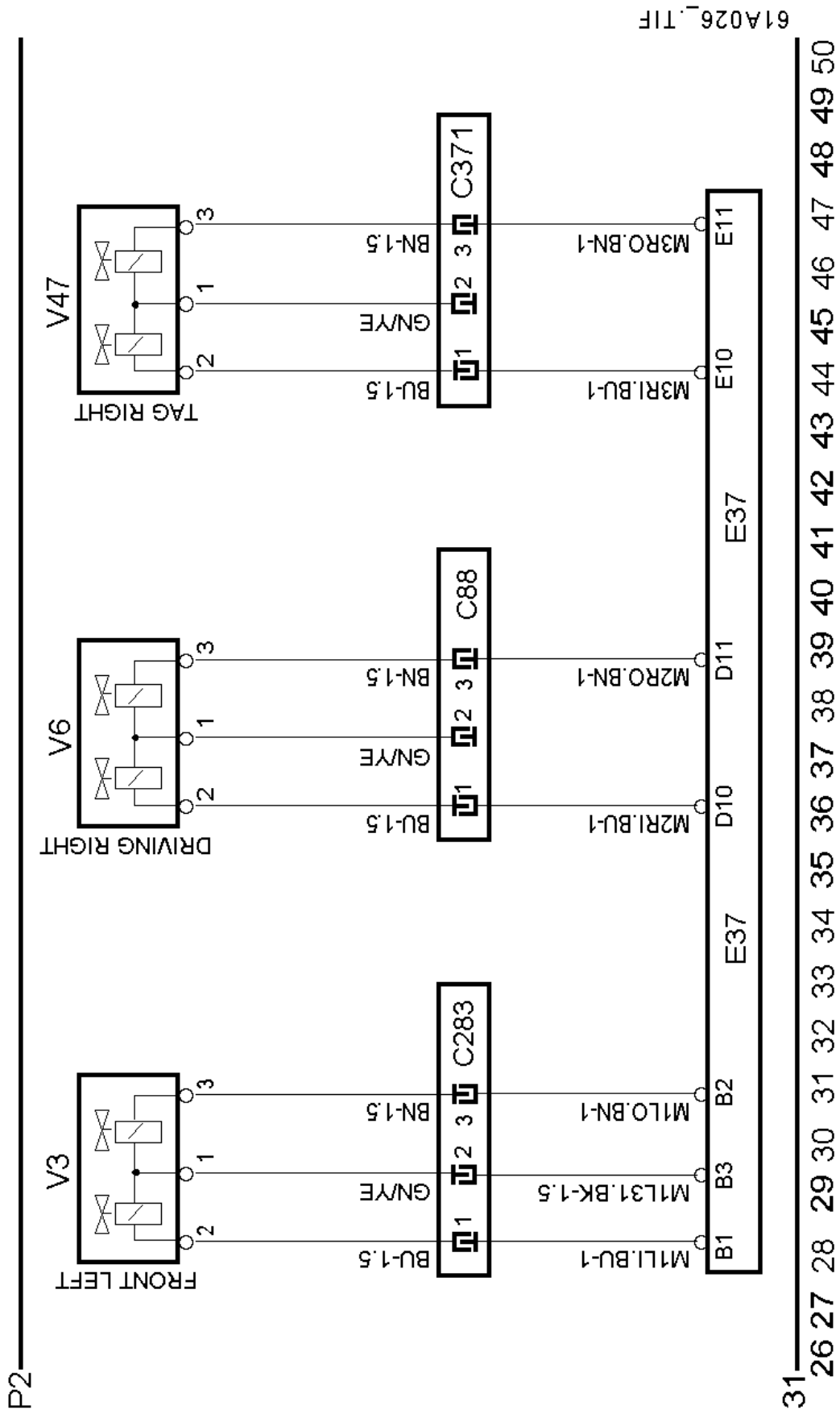

cardiagn.com

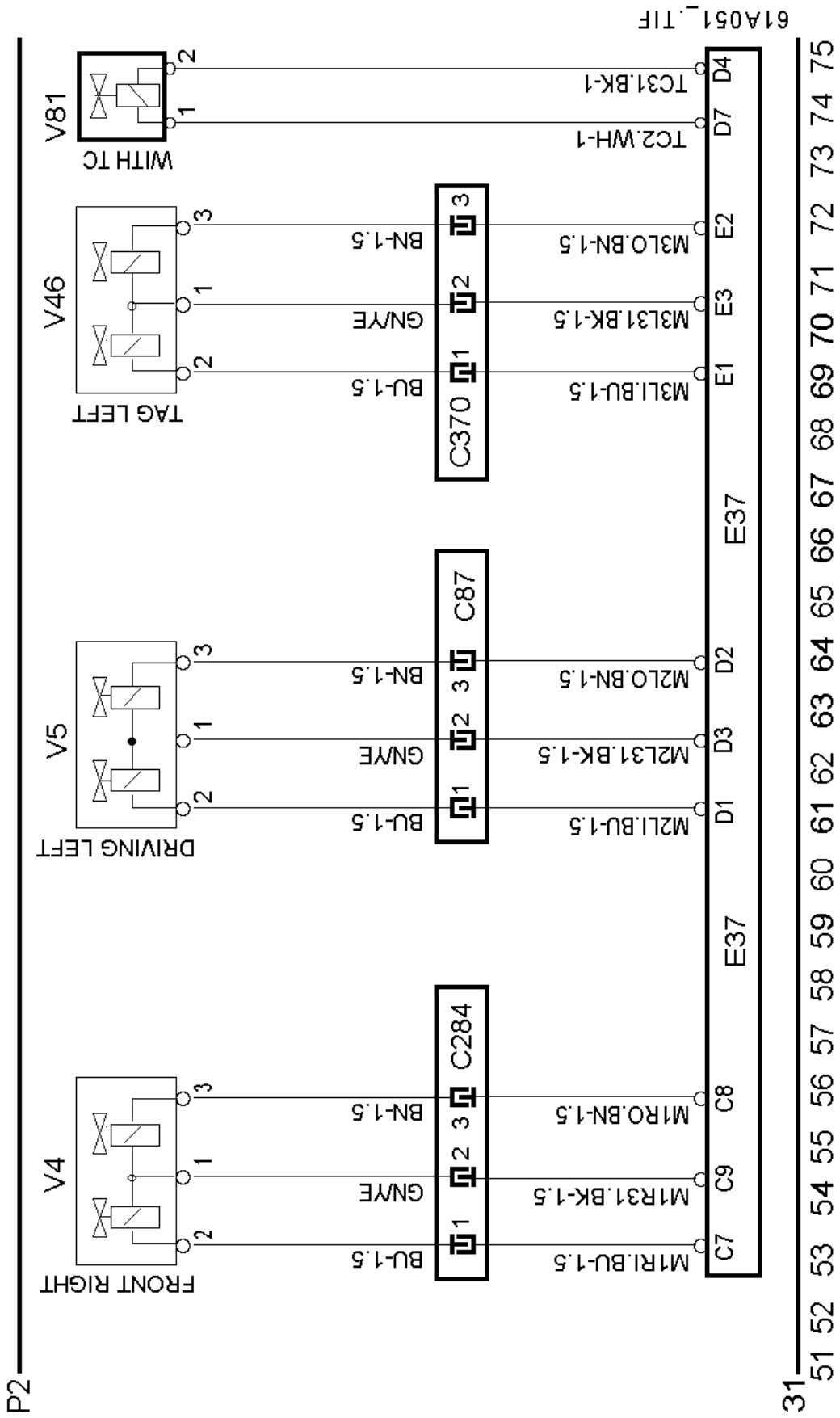

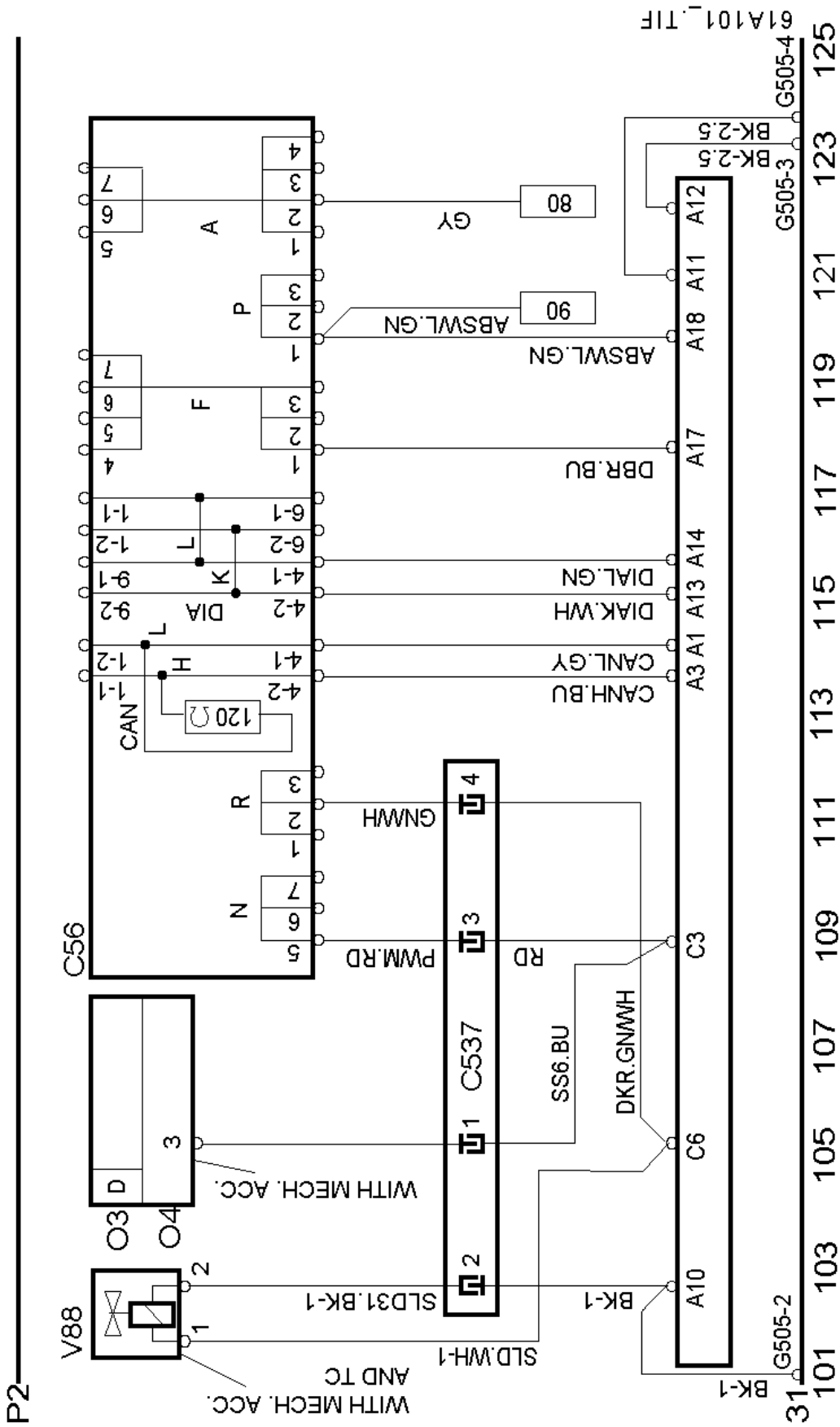

cardiagn.com

Input signals

The tables on this spread show which input signals the control unit can receive.

Input signals

Function	Source	Signal type	Pin
Activates TC Off Road program	Switch, S503	Earthing (0V)	A-6
Activates diagnostics/system modes	Diagnostics switch, S95	Earthing (0V)	A-16
Shows vehicle road speed (SLD/ EDC-PWM)	Tachograph, O4/ Distribution terminal, C56	Frequency, PWM	C-3
Shows wheel speed	Sensor beside left-hand front wheel, T11	Frequency	B4, B-5
Shows wheel speed	Sensor beside right-hand front wheel, T12	Frequency	C-4, C-5
Shows wheel speed	Sensor beside left-hand wheel axle 2, T13	Frequency	D-5, D-6
Shows wheel speed	Sensor beside right wheel axle 2, T14	Frequency	D-8, D-9
Shows wheel speed	Sensor beside left wheel axle 3, T28	Frequency	E-5, E-6
Shows wheel speed	Sensor beside right wheel axle 3, T30	Frequency	E-8, E-9

Output signals

The tables on the following pages show which output signals can be supplied by the control unit.

Output signals

Function	Destination	Signal type	Pin
Lights TC indicator lamp	TC indicator lamp, O500 (instrument cluster)	Earthing (0V)	A-16
Lights diagnostics lamp	Diagnostics switch, S95		
Shows ABS control (DBR signal)	Distribution terminal, C56	Earthing (0V)	A-17
Lights lamp	ABS warning lamp via distribution terminal, C56-O500	Earthing (0V)	A-18
Requests reduction of engine speed (SLD/ EDC-PWM)	Proportional valve, V88/ Distribution terminal, C56	PWM	C-6
Requests TC control	Solenoid valve TC, V81	+24V	D-7
Requests brake control	Control valve, pressure reduction left wheel axle 1, V3	+24V	B-1
Requests brake control	Control valve, pressure maintenance left wheel axle 1, V3	+24V	B-2
Requests brake control	Control valve, pressure reduction right wheel axle 1, V4	+24V	C-7
Requests brake control	Control valve, pressure maintenance right wheel axle 1, V4	+24V	C-8
Requests brake control	Control valve, pressure reduction left wheel axle 2, V5	+24V	D-1
Requests brake control	Control valve, pressure maintenance left wheel axle 2, V5	+24V	D-2

Output signals continued

Function	Destination	Signal type	Pin
Requests brake control	Control valve, pressure reduction right wheel axle 2, V6	+24V	D-10
Requests brake control	Control valve, pressure maintenance right wheel axle 2, V6	+24V	D-11
Requests brake control	Control valve, pressure reduction left wheel axle 3, V46	+24V	E-1
Requests brake control	Control valve, pressure maintenance left wheel axle 3, V46	+24V	E-2
Requests brake control	Control valve, pressure reduction right wheel axle 3, V47	+24V	E-10
Requests brake control	Control valve, pressure maintenance right wheel axle 3, V47	+24V	E-11

Other connections

The table below shows the control unit connections for power supply, system earth, communications lines etc.

Other connections

Function	Source or destination	Signal type	Pin
CAN communication	Distribution terminal, C56	Data CANL	A-1
CAN communication	Distribution terminal, C56	Data CANH	A-3
Power supply to control unit	Fuse number 23 in central electric unit	+24V	A-7
Power supply to control valves, diagonal 2 (see page 13)	Fuse number 18 in central electric unit	+24V	A-8
Power supply to control valves, diagonal 1 (see page 13)	Fuse number 21 in central electric unit	+24V	A-9
Diagnostics communication	Distribution terminal, C56	Data DIAK	A-13
Diagnostics communication	Distribution terminal, C56	Data DIAL	A-14
Earthing control unit	Earthing terminal, G505-2	Earthing (0V)	A-10
Earthing of diagonal 2 (see page 13)	Earthing terminal, G505-3	Earthing (0V)	A-11
Earthing of diagonal 1 (see page 13)	Earthing terminal, G505-4	Earthing (0V)	A-12
Separate earth to the control valves for diagonal 2 (see page 13)	Control valves, V3, V6 and V47	Earthing (0V)	B-3
Separate earth to the control valves for diagonal 1 (see page 13)	Control valves, V4, V5 and V46	Earthing (0V)	C-9
Separate earth to solenoid valve for TC	Solenoid valve TC, V81	Earthing (0V)	D-4

Pin numbering on control unit

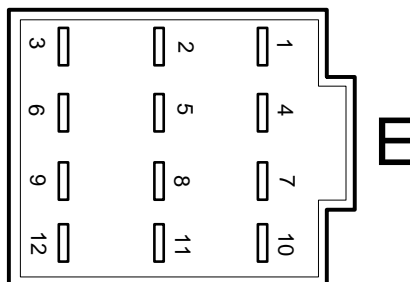
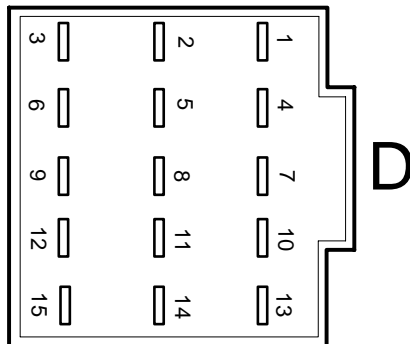
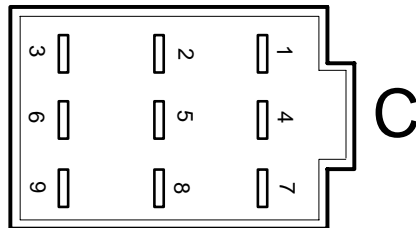
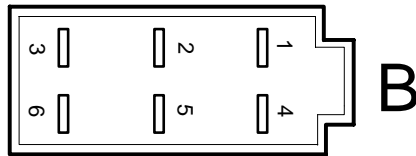
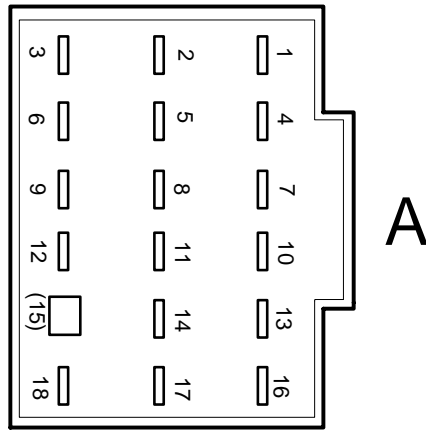

102 055

cardiagn.com

Specifications

Component	Designation	Resistance, Ohm
T11/T12	Wheel sensor front, after May 1993	1100 - 1900
T13/T14	Wheel sensor axle 2, after February 1994	1100 - 1900
T28/T30	Wheel sensor axle 3, after February 1994	1100 - 1900
V3/V4/V5/V6/ V46/V47	Control valve/in	14 - 21
V3/V4/V5/V6/ V46/V47	Control valve/out	14 - 21
V81	TC solenoid valve	54 - 63
V88	Proportional valve	18 - 30