

Wabco ABS/TC "C3" bus 6-channel system

Work description

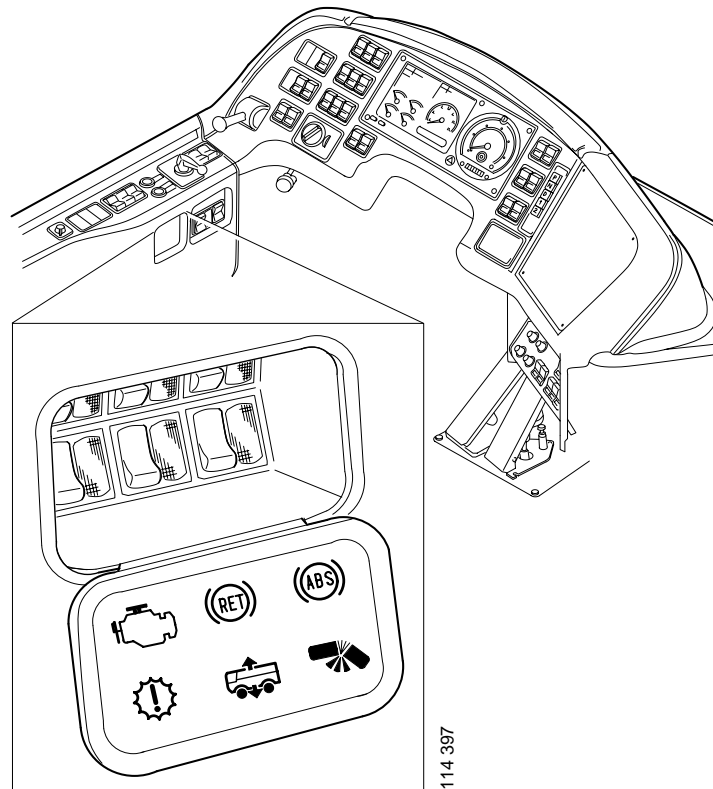

cardiagn.com

Contents

Features, general	Control unit, ABS/TC.....	3
	Features, general.....	3
Troubleshooting	Diagnostics panel.....	4
	Fault code readout.....	4
	Flashing code structure.....	6
	Multimeter testing.....	7
	Troubleshooting procedure.....	7
	Fault codes.....	8
	Connection of wheel diagonals.....	12
	Fault code generation.....	13
	Limit values for wheel rolling circumference.....	14
Electrical system	Specifications.....	17
	Associated diagram in group 16.....	18
	Colour codes for electrical wiring.....	18
	Component locations.....	19
	Circuit paths.....	20

Control unit, ABS/TC

Function

Features, general

Scania has introduced ABS version Wabco C3, 6-channel on 4 series buses. The control unit can be diagnosed by means of flashing codes, as described in this booklet, and by means of Scania Diagnos.

One significant feature of Wabco C3 is that the diagnostics switch has a fixed position, i.e. does not return automatically.



WARNING!

If the difference in tyre dimensions is too great the ABS system may not operate properly, causing longer stopping distance. Maximum permissible difference in circumference between front and rear wheels is 14%.

Scania Diagnos ABS/TC

Fault code readout

Diagnostics panel

This version of WABCO ABS/TC has an integral troubleshooting/diagnostics system. The diagnostics panel is located to the left of the instrument panel and contains a switch for activating and erasing the diagnostics memory as well as a diagnostics lamp for fault codes.

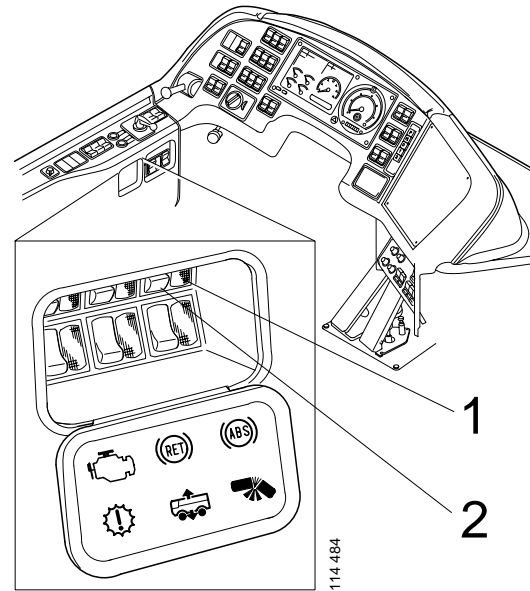

- 1 *Diagnostics lamp*
- 2 *Diagnostics switch, ABS*

Fault code readout

The ABS system can store several fault codes for each diagonal circuit but the diagnostics lamp can only display one fault code at a time. The active fault code, i.e. for the fault currently existing on the vehicle, is displayed first. Fault codes stored in the control unit are displayed in numerical order, the fault code with the lowest number being displayed first. To be able to read out the next code, the currently displayed fault code must be erased.

Readout without erasing:

- 1 Switch on the starting voltage.
- 2 Switch on the diagnostics switch.
- 3 Make a note of the fault code.
- 4 Switch off the starting voltage.
- 5 Switch off the diagnostics switch.

Readout and erase at the same time:

- 1 Switch on the starting voltage.
- 2 Switch on the diagnostics switch.
- 3 Do not switch off the diagnostics switch until the lamp starts flashing.
- 4 The lamp will continue flashing although the diagnostics switch is switched off.
- 5 Make a note of the fault code.
- 6 When the lamp stops flashing, the fault code has been erased.

Note: The fault code will only be erased if the fault is no longer active.

To be able to read out the next fault code, the starting voltage must be switched off before the procedure is repeated.

Flashing code structure

Starting block

By displaying a 2.5 second flash (SB in the illustration) the control unit indicates that the flashing code starts.

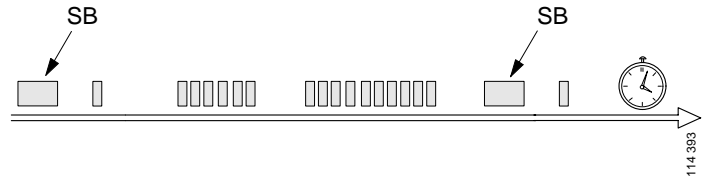

A black rectangle indicates that the diagnostics lamp is on.

Configuration block

The configuration block (KB in the illustration) indicates what type of control unit you are communicating with. The current type is:

6-channel ABS = 1 flash

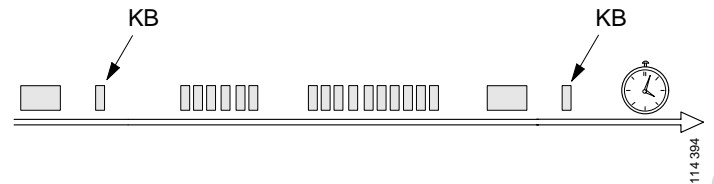

Fault code

The fault code (AF in the illustration) consists of two digits (1 and 2 in the illustration)

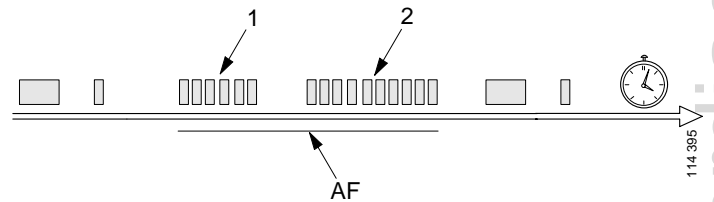

Fault code 6-10

No fault codes stored

If no fault codes are stored in the control unit, or if all fault codes have been erased, the control unit will only flash the starting block and the configuration block.

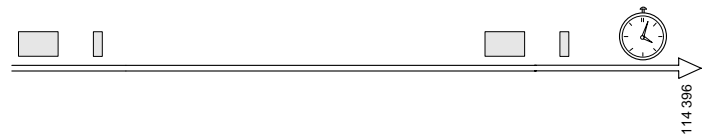

No fault codes stored

Troubleshooting

Multimeter testing

There is no Scania test instrument adapted to the control unit connectors.

IMPORTANT! Do not measure on the terminals of the control unit connectors. Measure on the rear of the connectors instead. Otherwise there is a risk of damage to the terminal pins of the connectors.

Troubleshooting procedure

- 1 Press the ABS diagnostics switch and read out the flashing code, refer to chapter "Flashing code structure", under "Scania Diagnos ABS". The current fault code or stored fault codes will be displayed. If there is a current fault code, the fault must be repaired before any stored codes can be displayed.
- 2 Check for faults according to the table under "Fault codes".
- 3 If a fault code is present, read the fault code text and find the circuit path concerned in the wiring diagrams. When in doubt as to what a component designation means, refer to the Wiring diagram handbook.
- 4 Select a suitable connector to measure on and locate the connector aided by the component illustration. Do not measure on the terminals of the control unit connectors. Measure on the rear of the connectors instead.
- 5 Measure using a multimeter and check the readings according to "Electronic control systems" under "Electrical systems" description of operation.

Fault codes

1st digit	2nd digit	Wheel	Description	Circuit path
6	6	1R/2L	Supply voltage to control unit too low.	130, 78
	7	1L/2R	Supply voltage to control unit too low.	130, 78
	8	1R	No vehicle speed signal.	15
	9	1L	No vehicle speed signal.	3
	10	1R	Incorrect wheel sensor resistance.	15
	11	1L	Incorrect wheel sensor resistance.	3
	12	1R	No reliable vehicle speed signal.	15
	13	1L	No reliable vehicle speed signal.	3
7	0	2L	No vehicle speed signal.	19
	1	2R	No vehicle speed signal.	7
	2	2L	Incorrect wheel sensor resistance.	19
	3	2R	Incorrect wheel sensor resistance.	7
	4	2L	No reliable vehicle speed signal.	19
	5	2R	No reliable vehicle speed signal.	7
	8	3L	No vehicle speed signal.	24
	9	3R	No vehicle speed signal.	11
	10	3L	Incorrect wheel sensor resistance.	24
	11	3R	Incorrect wheel sensor resistance.	11
	12	3L	No reliable vehicle speed signal.	24
	13	3R	No reliable vehicle speed signal.	11
	8	0	1R/2L	Internal fault in control unit.
1		1L/2R	Internal fault in control unit.	-
2		-	Output to proportional valve for speed limiter, open circuit. This flashing code should not be generated since pin 12 on the control unit is not connected.	-
3		-	PWM output signal (pin 29) to control unit for articulation control system, short to ground or short to 24 V.	144
4		-	Output to proportional valve for speed limiter, short to ground . This flashing code should not be generated since pin 12 on the control unit is not connected.	-
5		-	Error message from control unit for electric throttle (pin 28).	134

1st digit	2nd digit	Wheel	Description	Circuit path
8	6	-	No vehicle speed signal from speedometer. This flashing code should not be generated since pin 10 on the control unit is not connected.	-
	7	-	PWM input signal (pin 28) from control unit for electric throttle, short to 24 V or harness damaged.	134
	9	-	PWM input signal (pin 28) from control unit for electric throttle, data transmission fault.	134
	10	1R	Output to control valve, short to ground.	55
	11	1L	Output to control valve, short to ground.	30
	12	1R	Output to control valve, open circuit.	55
	13	1L	Output to control valve, open circuit.	30
	14	1R	Output to control valve, short to ground.	55
	15	1L	Output to control valve, short to ground.	30
9	0	1R	Output to control valve, open circuit.	55
	1	1L	Output to control valve, open circuit.	30
	2	2L	Output to control valve, short to ground.	61
	3	2R	Output to control valve, short to ground.	37
	4	2L	Output to control valve, open circuit.	61
	5	2R	Output to control valve, open circuit.	37
	6	2L	Output to control valve, short to ground.	61
	7	2R	Output to control valve, short to ground.	37
	8	2L	Output to control valve, open circuit.	61
	9	2R	Output to control valve, open circuit.	37
	10	3L	Output to control valve, short to ground.	67
	11	3R	Output to control valve, short to ground.	47
	12	3L	Output to control valve, open circuit.	67
	13	3R	Output to control valve, open circuit.	47
	14	3L	Output to control valve, short to ground.	67
15	3R	Output to control valve, short to ground.	47	
10	0	3L	Output to control valve, open circuit.	67
	1	3R	Output to control valve, open circuit.	47
	2	2L	Output to TC solenoid valve, short to ground.	72
	3	2R	Output to TC solenoid valve, short to ground.	74
10	4	2L	Output to TC solenoid valve, open circuit.	72

cardiagn.com

1st digit	2nd digit	Wheel	Description	Circuit path
	5	2R	Output to TC solenoid valve, open circuit.	74
	7	-	Output for disconnection of retarder/ auxiliary brake, pin 11, short to 24 V.	132
	8	2L	Slipping rear wheel.	-
	9	2R	Slipping rear wheel.	-
11	12	1R	Output to control valve, short to supply voltage.	55
	13	1L	Output to control valve, short to supply voltage.	30
	14	2L	Output to control valve, short to supply voltage.	61
	15	2R	Output to control valve, short to supply voltage.	37
12	0	3L	Output to control valve, short to supply voltage.	67
	1	3R	Output to control valve, short to supply voltage.	47
	2	2L	Output to TC solenoid valve, short to 24 V.	72
	3	2R	Output to TC solenoid valve, short to 24 V.	74
	4	-	Output to proportional valve for speed limiter, short to supply voltage. This flashing code should not be generated since pin 12 on the control unit is not connected.	-
	7	-	Output for disconnection of retarder/ auxiliary brake, pin 11, short to ground.	132
	8	1R	Output to control valve, short to 24 V.	55
	9	1L	Output to control valve, short to 24 V.	30
	10	2L	Output to control valve, short to 24 V.	61
	11	2R	Output to control valve, short to 24 V.	37
	12	3L	Output to control valve, short to 24 V.	67
	13	3R	Output to control valve, short to 24 V.	47
12	14	2L	Output to TC solenoid valve, short to 24 V.	72
	15	2R	Output to TC solenoid valve, short to 24 V.	74
13	0	-	Output to proportional valve for speed limiter, short to 24 V. This flashing code should not be generated since pin 12 on the control unit is not connected.	-
	4	1R/2L	Relay R359 is always closed.	78
	5	1L/2R	Relay R538 is always closed.	87
	6	-	Internal fault in control unit.	-

1st digit	2nd digit	Wheel	Description	Circuit path
	7	-	Internal fault in control unit.	-
	8	1R/2L	Supply voltage to control unit too high.	130, 78
	9	1L/2R	Supply voltage to control unit too high.	130, 87
	10	-	Internal fault in control unit.	-
	11	-	Internal fault in control unit.	-
	12	-	Internal fault in control unit.	-
	13	-	Internal fault in control unit.	-
	14	-	Internal fault in control unit.	-
	15	-	Internal fault in control unit.	-
14	0	-	Internal fault in control unit.	-
	1	-	Internal fault in control unit.	-
	2	-	Internal fault in control unit.	-
	3	-	Internal fault in control unit.	-
	4	-	Internal fault in control unit.	-
	5	-	Internal fault in control unit.	-
	6	1R/2L	Activation time for control valve exceeded.	-
	7	1L/2R	Activation time for control valve exceeded.	-
	8	2L	Activation time for TC solenoid valve exceeded.	-
	9	2R	Activation time for TC solenoid valve exceeded.	-
	10	-	Internal fault in control unit.	-
	11	-	Internal fault in control unit.	-
	12	-	Internal fault in control unit.	-
	13	-	Internal fault in control unit.	-
14	14	-	Internal fault in control unit.	-
	15	-	Internal fault in control unit.	-

Connection of wheel diagonals

The illustrations below show the numerical order of the vehicle axles. The lines show the wheel diagonals, i.e. the wheels on the front and rear axles that have diagonal electrical connections to the ABD/TC control unit.

Diagonal 1 = RH front/LH axle 2/LH axle 3

Diagonal 2 = LH front/RH axle 2/RH axle 3

In case of some electrical faults in the ABS/TC system, only the faulty diagonal will be disconnected.

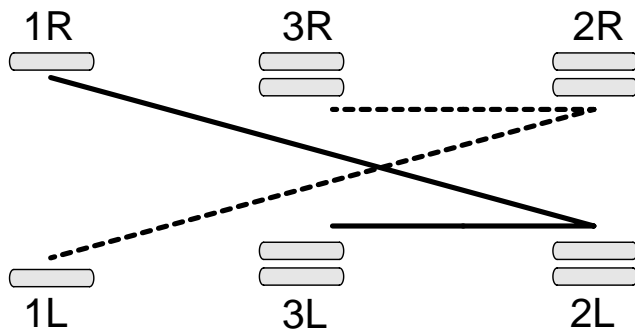
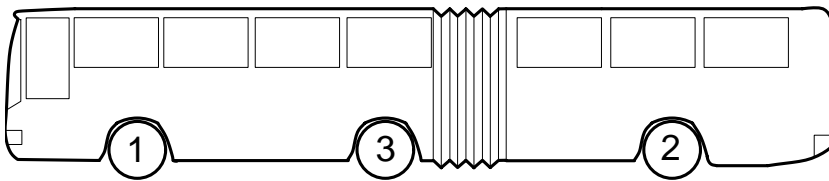

114 398

Fault code generation

A fault code for short/open circuit may be generated after power-on when the vehicle is stationary. The remaining fault codes are generated based on wheel sensor frequency change, and thus the vehicle must be in motion.

In case of short to ground or +24 V, the diagonal in which the fault has occurred will be disconnected. In case of internal fault in the control unit, the system will be entirely or partially disconnected.

The most commonly occurring fault codes are generated due to excessive air gap between sensor and pulse wheel or damaged/contaminated pulse wheel.

Limit values for difference in wheel rolling circumference between front and rear wheels

On vehicles equipped with ABS/TC too large differences between front and rear wheel rolling circumference may cause faulty signals to the control unit, resulting in increased stopping distance. Starting from the tyre manufacturer's values for tyre rolling circumference, select tyres so that the maximum difference is:

+ 14,0 % if front wheels are larger than rear wheels

- 14.0 % if front wheels are smaller than rear wheels

$$\text{Difference (\%)} = \frac{\text{Rolling circumference, front} - \text{Rolling circumference, rear}}{\text{Rolling circumference, front}} \times 100$$

Example:

Tyres, front axle: 315/80R 22,5

Rolling circumference: 3329 mm

Tyres, rear axle: 12R 22,5

Rolling circumference: 3360 mm

$$\text{Difference (\%)} = \frac{3329 - 3360}{3329} \times 100 = -0.9\%$$

The difference is acceptable since maximum permissible difference is -14.0 %.

Electrical system

Specifications

Components

Component	Description	Resistance, ohms
T11/T12	Wheel sensor, front	1100-1900
T13/T14	Wheel sensor, axle 2	1100-1900
T28/T30	Wheel sensor, axle 3	1100-1900
V3/V4/V5/V6/ V46/V47	Control valve/input	14-21
V3/V4/V5/V6/V46/V47	Control valve/output	14-21
V81	TC solenoid valve	54-63

Wiring diagrams

In the flashing codes table in section "Troubleshooting" references are made to circuit paths.

The wiring diagrams are to be found after the component location illustration. The diagrams contain consecutive circuit path numbers. Use circuit path references from the flashing codes table to find the relevant diagram and components.

The diagrams contain component designations, e.g. E37. The full names of the components are stated in the Wiring diagram handbook, refer to Workshop manual, group 16.

Associated diagram in group 16

16:54-39

Colour codes for electrical wiring

BK	Black
BN	Brown
RD	Red
OG	Orange
YE	Yellow
GN	Green
BU	Blue
VT	Violet
GY	Grey
WH	White
PK	Pink

Component location

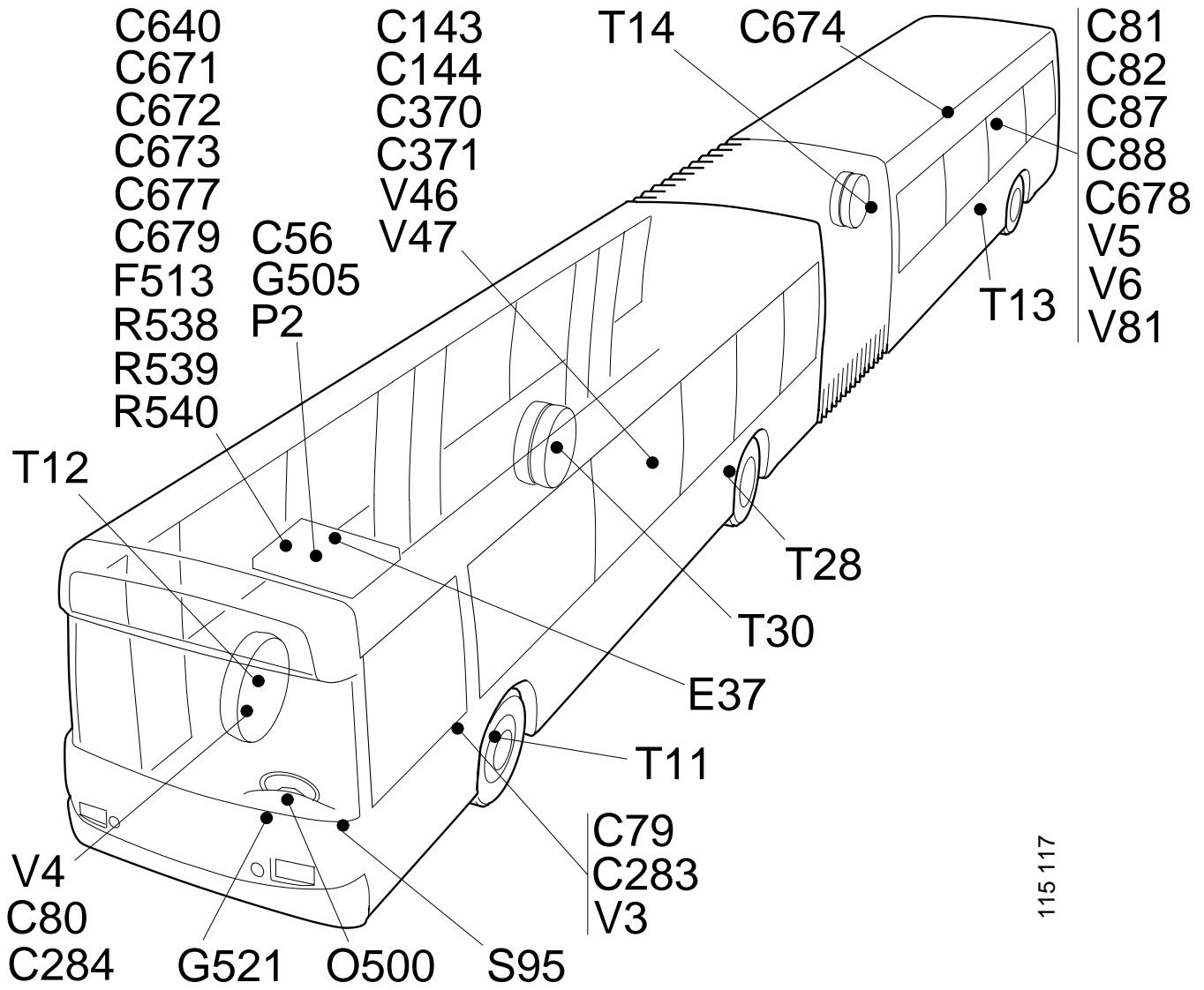

cardiagn.com

Electrical system

Circuit paths Wabco C3 bus

Circuit paths 1 - 25

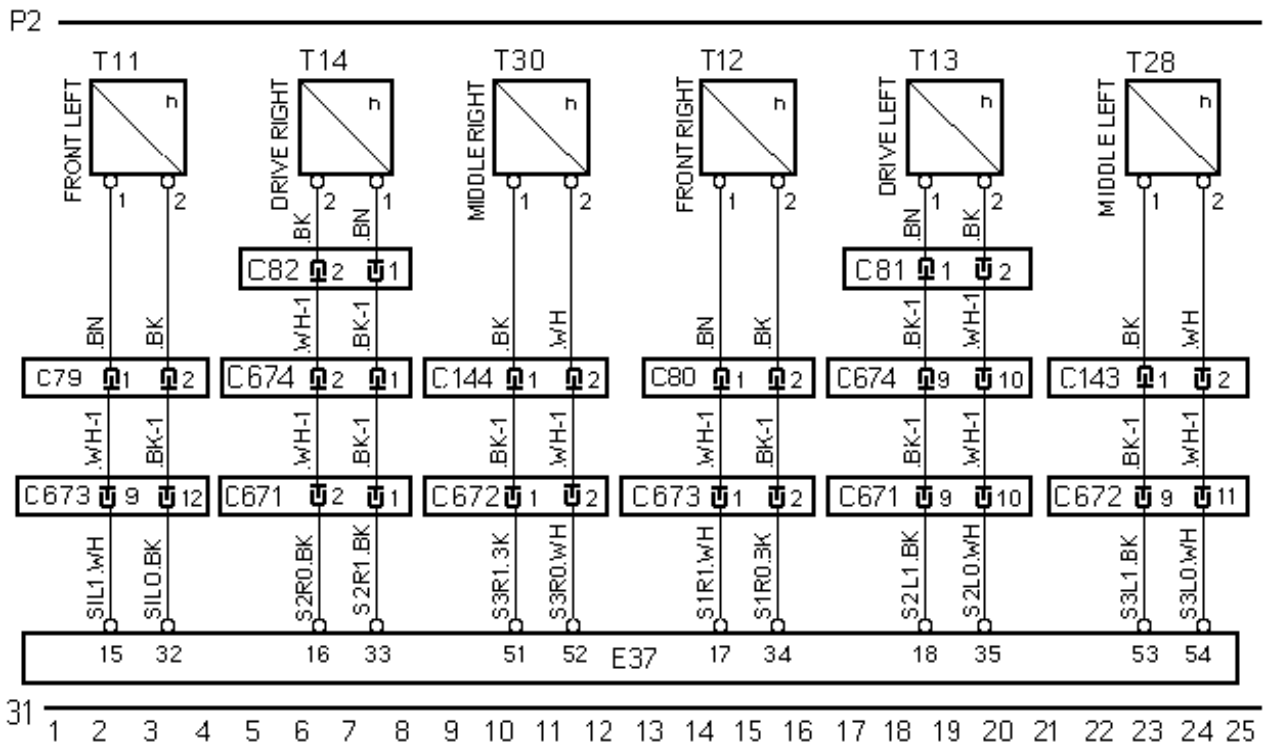

114406

Circuit paths 26 - 50

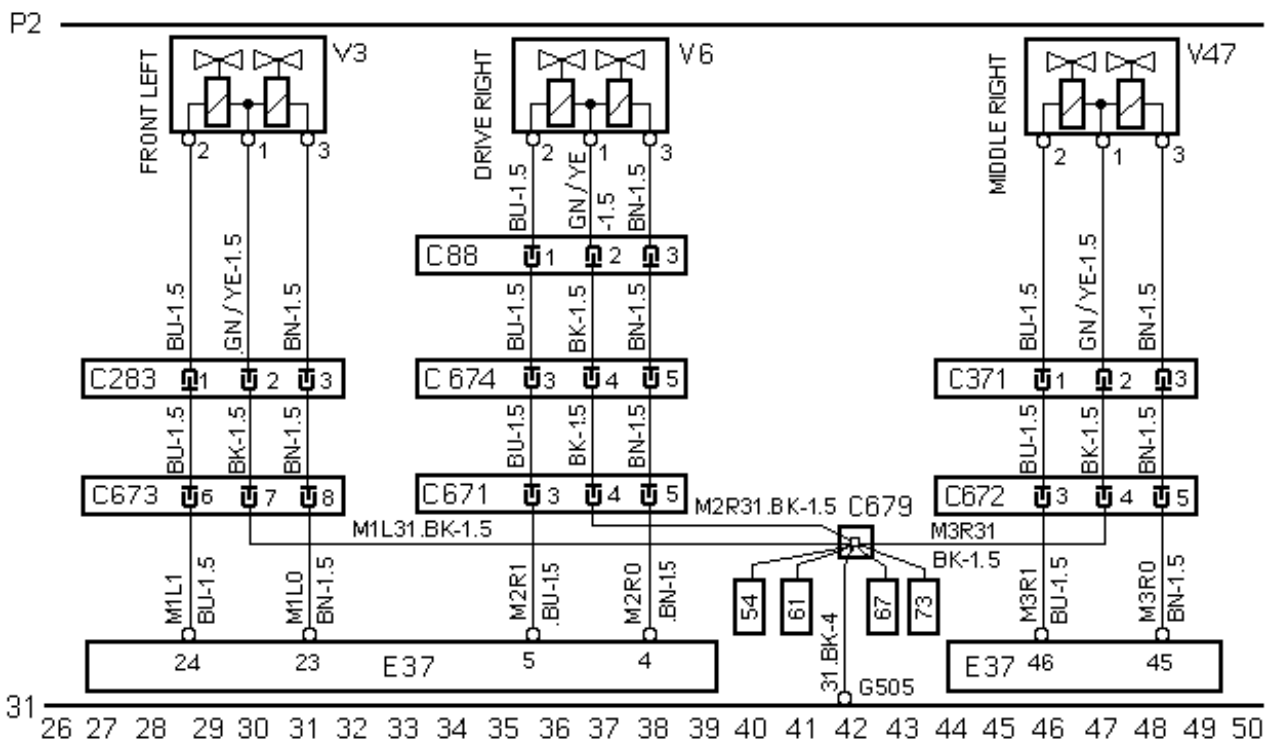

114407

Circuit paths 51 - 75

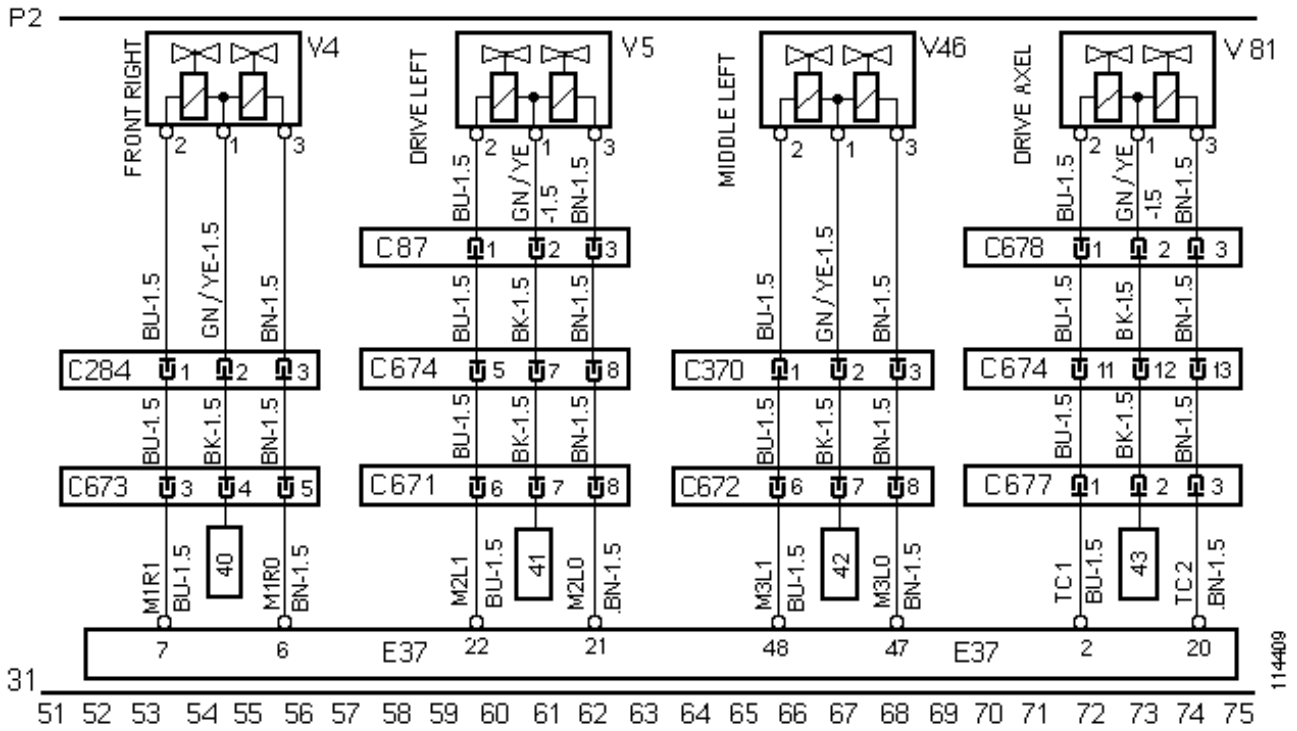

Circuit paths 76 - 100

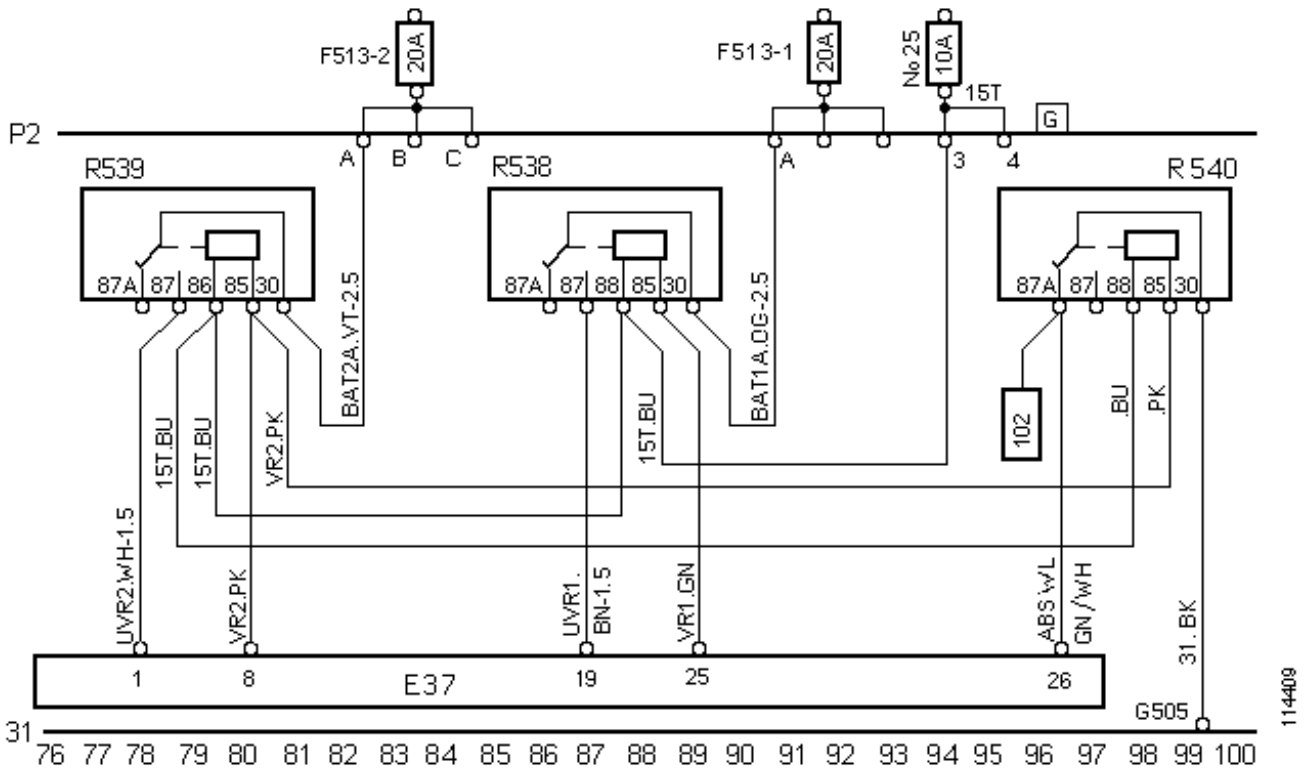

Circuit paths 101 - 125

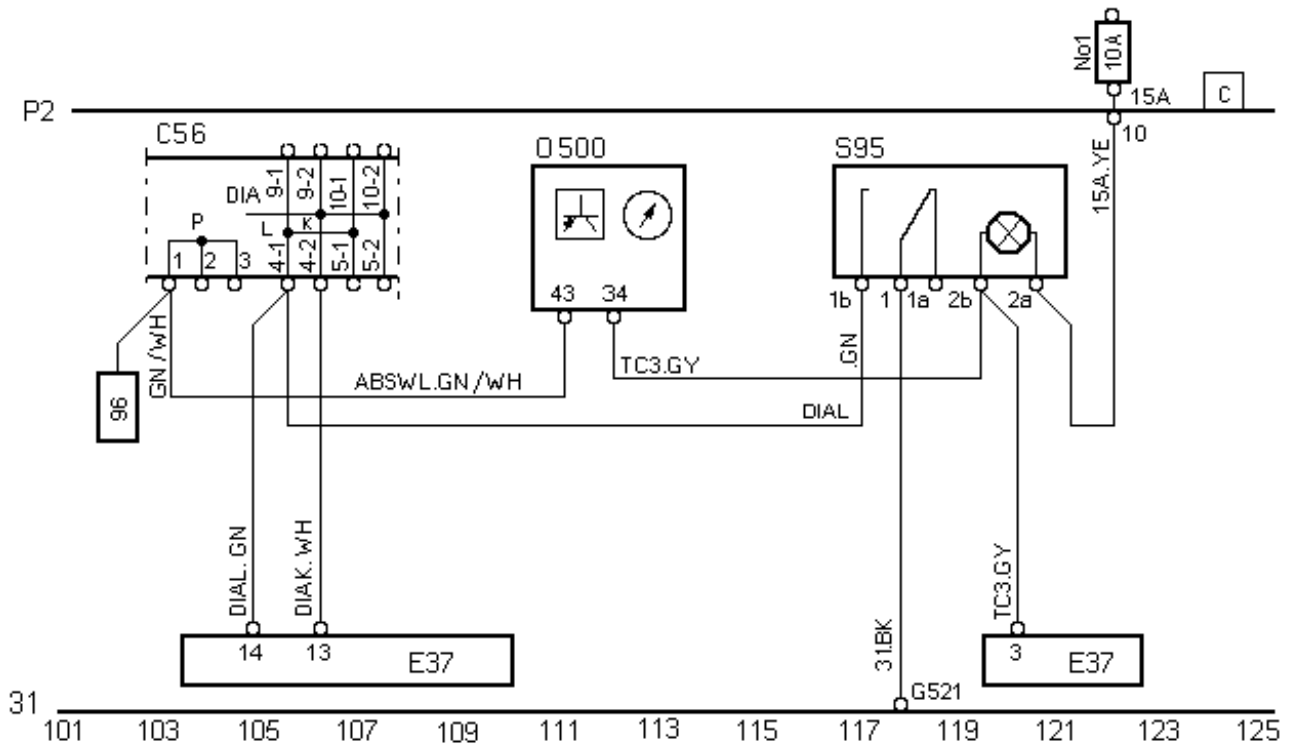

Circuit paths 126 - 150

