

SCANIA

10:05-07

Issue 2 **en**

Scania Retarder

Function description

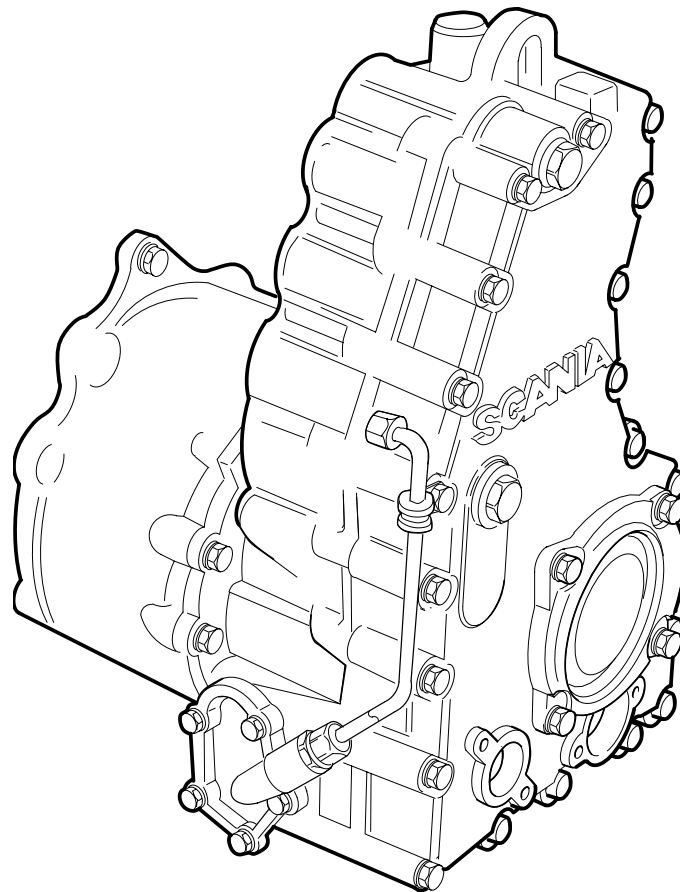

10:2288

cardiagn.com

Contents

Electrical System	General.....	3
	The design of the system	4
Interaction with other systems	7
	Retarder CAN	9
Brake sensor functions	Brake pedal sensor.....	11
	Lever sensor.....	13
System functions	Brake lamp.....	14
	Limiting at high temperatures.....	14
	ABS/EBS communication, general	15
	EDC communication, general.....	17
	Exhaust brake	18
	MBP (engine brake program) output.....	21
	Warming up the driver and passenger compartments.....	22
Configuration	General.....	23
	Configuration codes.....	24
	Configuration, explanations.....	27
	Control unit as a part.....	29
Control unit connections	31
Warning system	General.....	35
	Warning lamp, fault indication	37
	Resetting the warning system	38

Electrical system

General

- The auxiliary brake control unit is microprocessor based.
- The control unit and its program are the same for all versions. How the control unit carries out its tasks depends on the configuration. This is described under the heading Configuration.
- The control unit is equipped with an integrated warning system, see Main group 10 Scania Retarder, Function description under the heading Warning system.

The design of the system

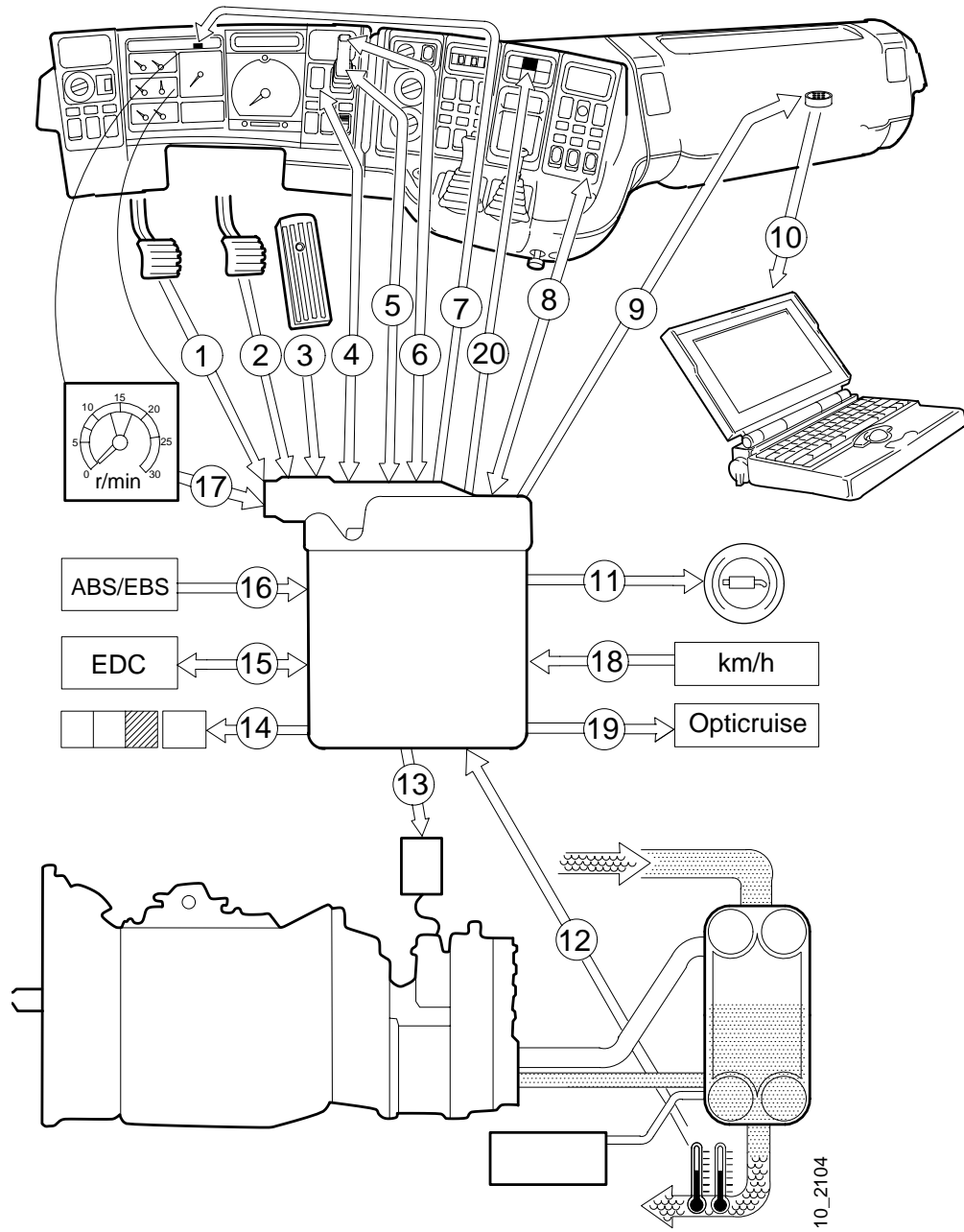

cardiagn.com

The illustration is general and applies to both trucks and buses. Vehicles with a lower level of equipment are covered where appropriate.

The design of the system

- 1 The clutch pedal switch is used to enable the driver to increase throttle when changing down without interrupting downhill speed control¹ or braking using the hand lever.
- 2 The brake pedal sensor is used to provide retarder braking using the brake pedal² and to automatically activate downhill speed control³.
- 3 The accelerator pedal sensor sends a signal to the control unit to interrupt downhill speed control or retarder braking that has been requested with the lever. If, on the other hand, the clutch pedal is in depressed position, retarder braking continues.
- 4 The AUT switch is used to make it possible for the retarder and downhill speed control to be activated automatically using the brake pedal. It must also be possible for the driver to shut down all retarder activation from the brake pedal e.g. on slippery surfaces.
- 5 The hand lever has six positions. The five brake positions each give a fixed braking torque: 500, 1000, 1500, 2000, 3000 Nm. In the max. position, the exhaust brake is also activated, according to the conditions under the heading System functions, Exhaust brake.
- 6 The switch on the top of the lever is for manual activation of downhill speed control.
- 7 Warning lamp to warn of faults in the auxiliary brake system or its adjoining systems and circuits.
- 8 Main exhaust brake switch. For trucks after 9911, this switch is only fitted to vehicles with automatic exhaust brake (EXB).
- 9 Diagnostic socket for PC.
- 10 PC with SD trouble shooting program.

Note: Actuating the accelerator pedal interrupts retarder braking when the clutch pedal is in the released position.

1. Downhill speed control requires the vehicle to be equipped with ABS/EBS.

2. Brake pedal control requires the vehicle to be equipped with ABS/EBS.

3. Optional equipment on trucks only.

- 11 The exhaust brake¹ is not controlled by the driver but by the control unit.
- 12 Dual temperature sensors at the outlet from the retarder oil cooler. The temperature forms the basis of the decision by the control unit for any temporary decrease in braking power.
- 13 The proportional valve controls brake torque to the requested level at different road speeds. As road speed decreases, the retarder requires higher and higher oil pressure to be able to brake with the requested torque. The proportional valve controls this and so enables the retarder to brake at speeds down to approx. 20 km/h.
- 14 The stop light illuminates when the auxiliary brake is applied. This is illegal in certain markets. This feature can be deactivated by removal of relay R8.
- 15 The auxiliary brake communicates with the EDC system to ensure that the two systems will not interfere with each other's operation. Braking disengages the cruise control of the EDC and depressing the accelerator disengages retarder braking.
- 16 The auxiliary brake receives information from the ABS/EBS system so that it can disengage retarder braking at short notice. Signals from the ABS/EBS system about ABS control interrupt retarder braking within 0.2 seconds. Retarder braking via the brake pedal as well as all downhill speed control are disengaged by any fault in the ABS-system.
- 17 The engine speed gives the control unit continuous information about available cooling capacity. The control unit can demand a temporary decrease in retarder power and so prevent overheating in the cooling system.
- 18 The auxiliary brake receives road speed data from the Opticruise, CS² or the gearbox over-revving protection. See paragraph 13.
- 19 The auxiliary brake orders the Opticruise system to switch to the engine brake program if engine speed and, accordingly, cooling capacity is insufficient.
- 20 The diagnostics lamp and diagnostics switch are concealed under a cover in the instrument panel.

1. Some buses are not equipped with exhaust braking.

2. Optional equipment on buses only.

Interaction with other systems

The block diagram at the end of this description shows which other systems are connected to the Scania auxiliary brake system and in which directions information is exchanged.

Fault codes are a part of this exchange of information and therefore, for example, the CS system fault codes will be shown under the auxiliary brake system.

The illustration applies to both trucks and buses and covers all appropriate optional equipment.

- The auxiliary brake is connected to the alternator's tachograph signal, W+. This means that the control unit can determine the speed of rotation of the coolant pump and thus also know the volume of coolant flow at any moment.

Retarder braking generates a great deal of heat and this must be dissipated by the vehicle's ordinary cooling system. Braking power may reach approx. 540 hp continuously and up to 880 hp for short periods.

Do not confuse the alternator signal W+ with the EDC systems PWM signal. The PWM signal gives the throttle position and not coolant flow.

- The auxiliary brake is connected to the EDC system to ensure that the two systems will not interfere with each other's operation.

The EDC must know if the driver is braking using the auxiliary brake, and then disengage the cruise control of the EDC.

Moreover, the auxiliary brake must be disengaged as soon as the driver accelerates, irrespective of whether he is accelerating with the pedal or with the cruise control of the EDC.

- The auxiliary brake is connected to the ABS/EBS system so that it will not interfere with ABS control.

The auxiliary brake brakes hard, but only on the driven wheels. For this reason the

ABS/EBS system disengages the auxiliary brake during ABS control. Afterwards, when ABS control has finished, the auxiliary brake can function as normal.

- The auxiliary brake is connected to the Opticruise, CS or the normal overrevving protection of the gearbox, so that the control unit can obtain data on the vehicle road speed.

The working parts of the auxiliary brake i.e. the retarder and the exhaust brake, have different effects at different road speeds. On the basis of the road speed, the control unit can decide how to achieve optimum braking and then activate the retarder, the exhaust brake or both.

- The auxiliary brake is connected to the Opticruise to enable it to request the activation of the engine brake program.

If the downhill speed control regulator in the auxiliary brake control unit perceives that it is not able to maintain speed, it can even order the Opticruise to change down as soon as possible.

Over long periods, it can be said that the auxiliary brake takes precedent over the Opticruise. In the short term the opposite is the case. For example, if the auxiliary brake has requested braking of the vehicle by means of the exhaust brake, the Opticruise system will still be able to control the exhaust brake during its gear-changes. When each gear-change is complete, the exhaust brake will again be used for braking the vehicle.

Retarder CAN

From 9911 the retarder control unit uses CAN communication to communicate with EBS control units. Applies to trucks only. The communication cables CAN LOW and CAN HIGH are connected to pins 39 and 40 on the retarder control unit.

CAN communication

CAN is an abbreviation of Controller Area Network. CAN communication is used to reduce the number of cables in the vehicle and at the same time increase reliability. CAN communication is serial data communication and can be compared to communication between computers in a network.

Every control unit that communicates using CAN is connected to the CAN LOW and CAN HIGH cables. Through these cables, each control unit continuously sends and receives CAN messages to and from other control units. Which CAN message the control unit sends or listens for depends on the configuration of the control unit.

As a mechanic, it is important to remember that individual CAN signals cannot be checked using a Multimeter.

Retarder CAN and EBS

EBS version 2.2 is introduced at the same time as Retarder CAN. These systems communicate using CAN if the configuration Brake torque via CAN is selected for the retarder in Scania Programmer.

If the retarder has this configuration, the EBS system will have priority over the retarder and via CAN signals, decide how much the retarder should brake when the brake pedal is depressed. The retarder then decides when and how much the exhaust brake should be activated for the requested brake torque.

CAN signals sent from EBS to the retarder are as follows:

- Requested brake torque
- ABS control

- EBS/ABS fault

CAN messages sent from the retarder to EBS are as follows:

- Regulated brake torque
- Configuration, max. retarder torque

Retarder CAN and EDC

For certain engine types with EDC, communication with the retarder occurs via the two CAN cables. Applies to trucks from 0005 only.

The retarder communicates with the EDC via CAN, if the configuration "Engine fan control" is selected in Scania Programmer.

When "Engine fan control" is selected, the retarder control unit will send CAN messages with the desired engagement level of the engine fan to the EDC control unit. The engagement level depends on the coolant temperature.

Vehicles equipped with a coordinator

The EDC control unit sends information concerning the current fuel volume and the current engine speed via CAN bus to the coordinator, COO. The coordinator converts the information and generates a PWM signal for current fuel volume and a W signal for the engine speed, these signals are sent to the retarder control unit, RET. The retarder control unit receives several other input signals, such as from the temperature sensor. When the retarder control unit senses too high a coolant temperature, it can send a signal on the CAN bus to the EDC control unit with a request for fan control. The EDC control unit then decides the engagement level.

On vehicles equipped with a coordinator, it is important that the retarder control unit is always programmed as if the vehicle had a 6 pole alternator with an alternator frequency of 172Hz. This is because the W signal that is generated by the coordinator is equivalent to the signal from a 6 pole alternator.

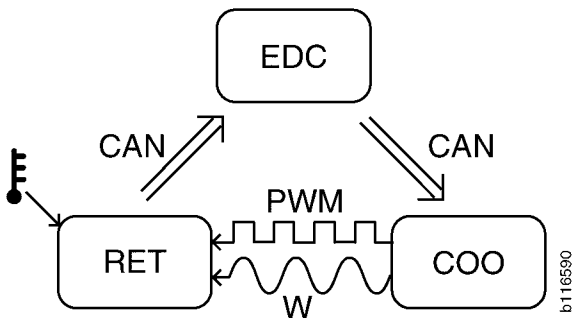

Scania integrated auxiliary brake system

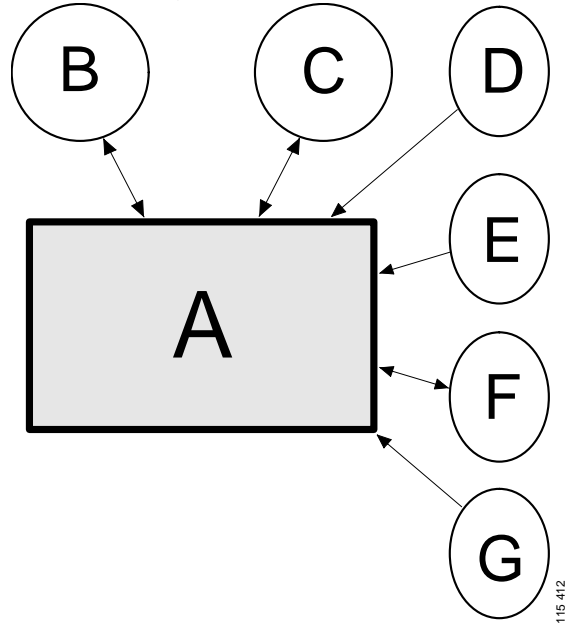

A Scania integrated auxiliary brake system

B EDC system

C Opticruise system

D CS system or overrevving protection

E ABS, ABS/TC or EBS system up to and including version 2.1

F EBS system from version 2.2 onwards

G Tachograph signal from the alternator

Signal routes between the auxiliary brake control unit and other computer controlled systems that may be fitted to the vehicle.

Any faults are transmitted from one system to another in the same direction as communication takes place (see arrows).

Brake sensor functions

How the auxiliary brake system controls are used is described in the Driver's manual.

Brake pedal sensor

The brake pedal sensor consists of a potentiometer that sends an analogue voltage to pin 23 on the control unit. The signal informs the control unit of the requested brake torque.

The potentiometer is built into the footbrake valve. The graph below shows how the voltage increases as the brake pedal is depressed.

Note: Note that the potentiometer already gives a voltage, approx. 0.5 V, before the brake pedal is depressed.

The control unit disregards the position of the brake pedal if the AUT switch is OFF. In this case, automatic downhill speed control is disengaged. In addition, the retarder braking which takes place at the beginning of brake pedal travel ceases¹i.e. before the wheel brakes are applied.

A fault in the ABS/EBS system up to and including EBS version 2.1 will also cause the control unit to ignore the signal from the brake pedal sensor. This applies as long as the ABS warning lamp is illuminated. When the lamp goes out, the control unit once again takes the position of the brake pedal into consideration. The control unit receives the message about the ABS/EBS fault on pin 14.

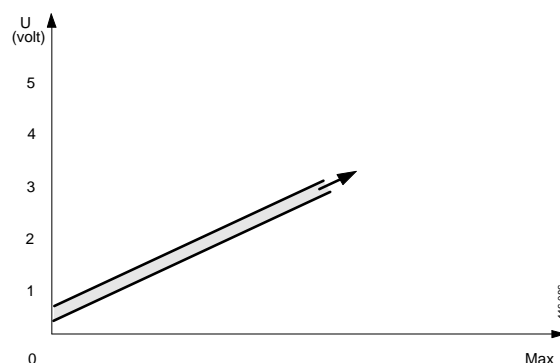

The brake pedal sensor is adjusted in such a way that the voltage starts to rise as soon as the pedal is actuated. The voltage should be within the grey zone. When the pedal is in the released position, the potentiometer provides approx. 0.5 V. Voltage increases up to approx. 4.5 V when the brake pedal is fully depressed.

¹The torque level is determined by the configuration. See graph under the headline Configuration, Configuration codes.

Retarder CAN and EBS

For trucks with EBS from version 2.2 onwards which have the retarder configuration Brake torque via CAN, the EBS system will have priority over the retarder and via CAN messages request the desired brake torque from the retarder when the brake pedal is depressed. Pin 23 on the retarder control unit is therefore not connected on these vehicles.

Application of the wheel brakes and the retarder is controlled completely by EBS when the brake pedal is depressed, so for these vehicles, no brake pedal characteristics are configured.

If faults occur in ABS/EBS, the option of retarder control by depressing the brake pedal is removed by the EBS ceasing to send the CAN message "ABS fully operational". Retarder control by depressing the brake pedal is not possible as long as the CAN message is not sent. The retarder control unit receives the message "ABS/EBS fault" on the CAN cables, pins 39 and 40. The ABS/EBS warning lamp is illuminated as long as the fault is active.

Note: The ABS/EBS warning lamp can be illuminated without the option brake pedal activation of the retarder being disconnected, i.e. the retarder is not disconnected for all types of EBS faults from version 2.2 onwards.

Hand lever sensor

The control unit receives the signal from the hand lever on pin 8. The signal informs the control unit of the requested brake torque.

The hand lever has six fixed positions. The five braking positions correspond to torque levels of 500, 1000, 1500, 2000 and 3000 Nm. In the max. position, the exhaust brake is also engaged¹. This occurs internally in the control unit. Hence there is no contact for this purpose in the hand lever sensor.

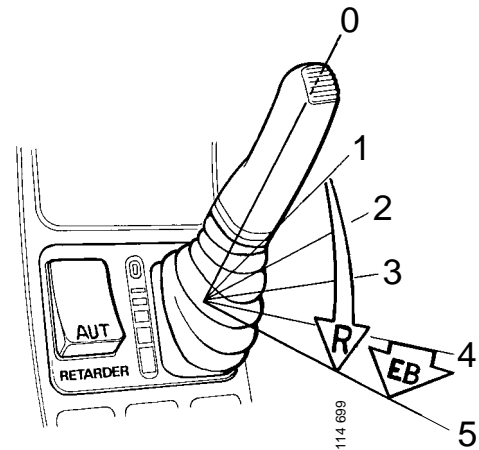

The hand lever has a sensor which provides an analogue voltage to the control unit. This voltage increases the more the lever is pulled down.

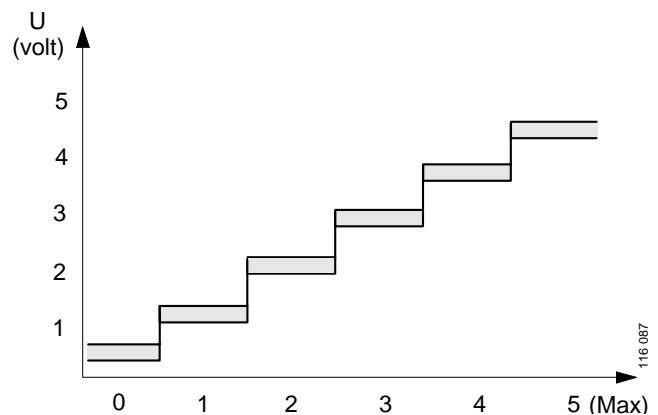

The voltage from the hand lever sensor should be within the grey zone. In position 0, the potentiometer shows approx. 0.5 V, and when the lever is moved to the max. position, about 4.5 V.

¹ Provided that the exhaust brake switch on the instrument panel is on.

System functions

Stop light

The stop light (and an indicator lamp that is standard only on trucks without ABS), is activated by the control unit under the following conditions.

- The stop light illuminates if the brake torque requested at the lever or brake pedal exceeds 450 Nm.
- The stop light also illuminates if the downhill speed control regulator in the control unit requests 900 Nm or more.
- The stop light goes out when the retarder brake torque drops below 300 Nm.

In certain countries it is illegal for the stop light to illuminate during retarder braking. This feature can be deactivated by removal of stop light relay R8.

Limiting at high temperatures

The braking power of the retarder is reduced if the cooling system cannot manage to dissipate the heat generated. The driver can increase the cooling capacity by changing down so that the engine runs at a higher engine speed. Cooling capacity, and thus braking power, is directly proportional to the engine speed.

If the retarder is not capable of holding the speed, the driver should brake, change down and try again at a lower road speed. When the coolant starts to return to its normal temperature, the retarder will gradually regain its original braking power.

The graph below shows how the available braking capacity of the retarder is decreased at high coolant temperatures.

The control unit monitors both brake torque and brake power with regard to the temperature. The temperature value is taken from both sensors at the outlet from the retarder oil cooler.

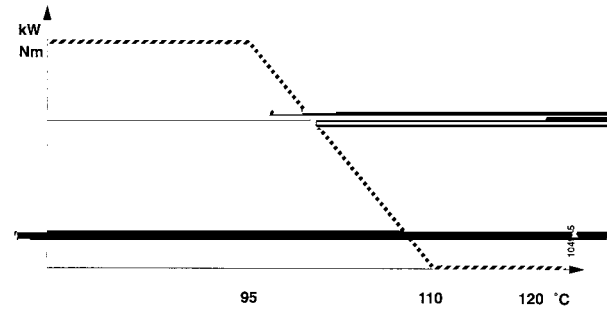

The configuration governs the maximum permitted magnitude of the power and torque in the vehicle. However, braking capacity always decreases according to the above graph.

Retarder CAN with fan control

From 0005 certain vehicles are equipped with engine fan control.

When the retarder configuration "Engine fan control" is selected, the retarder control unit will send CAN messages with the desired engagement level of the engine fan to the EDC control unit. The engagement level depends on the coolant temperature.

ABS/EBS communication, general

Signals from the ABS system about ABS control interrupt retarder braking within 0.2 seconds. This is done by the control unit simultaneously breaking the current to the solenoid for compressed air supply¹ and to the proportional valve. In this way, the compressed air, that held the braking oil in the retarder, is released. The power to the exhaust brake solenoid valve is interrupted simultaneously.

ABS control

The auxiliary brake control unit is immediately notified on pin 35 that ABS control has begun. Retarder braking interferes with ABS control.

The ABS system disconnects the auxiliary brake during ABS control, in order to give the ABS system free scope. Afterwards, when ABS control has ceased, the driver can again use the auxiliary brake.

If it was downhill speed control that was interrupted by ABS control, this is gently restored as soon as ABS control ceases.

For trucks with retarder configuration Brake torque via CAN (from EBS version 2.2 onwards) the signal ABS control is sent to the retarder as a CAN message. The communication cables CAN LOW and CAN HIGH are connected to pins 39 and 40 on the retarder.

1.Called ON/OFF in the wiring diagram in Main group 16. From 9908 for trucks and from 9910 for buses, this valve is a part of component V97.

ABS/EBS warning

The ABS/EBS control unit lights the ABS/EBS warning lamp if there is a fault in the ABS/EBS system. The same signal is used by the auxiliary brake control unit to interrupt both retarder braking via the brake pedal and downhill speed control. Conversely, it will be possible to use the hand lever positions. The control unit receives the ABS/EBS warning on pin 14.

For trucks with EBS from version 2.2 onwards and with retarder configuration Brake torque via CAN, the choice of retarder control by depressing the brake pedal is removed by the EBS ceasing to send the CAN message "ABS fully operational". Retarder control by depressing the brake pedal is not possible as long as the CAN signal is not sent. The retarder control unit receives the ABS/EBS fault message on the CAN cables, pins 39 and 40. The ABS/EBS warning lamp is illuminated as long as the fault is active.

Note: The ABS/EBS warning lamp can be illuminated without brake pedal activation of the retarder being disconnected, i.e. the retarder is not disconnected for all types of EBS faults from version 2.2 onwards.

EDC communication, general

EDC system, PWM signal

The auxiliary brake control unit senses the throttle position of the EDC engine by reading the pulse width modulated (PWM) signal. Pulse width increases with increased throttle activation.

The auxiliary brake control unit receives the PWM signal on pin 12. The signal is illustrated in the figures below.

The PWM signal is a constant frequency square wave. The voltage level U is also constant. The variable is the activation time, calculated as a percentage of each cycle.

The PWM signal carries information very accurately to the control units. The auxiliary brake control unit will immediately generate a fault code if the PWM signal seems implausible.

Note: The PWM signal cannot be reliably read using an ordinary multimeter. Instead, use the fault codes to locate the cause of any possible malfunctions.

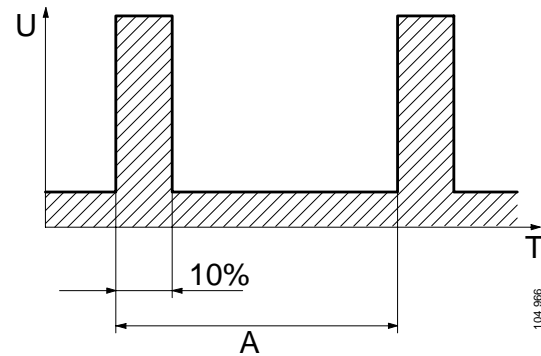

A Cycle time

A PWM signal with a pulse width of 10% indicates zero torque.

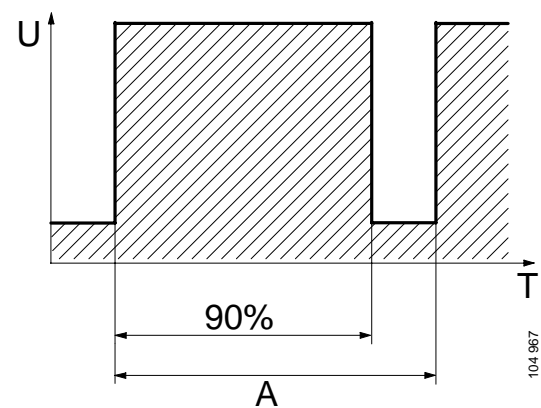

A Cycle time

A PWM signal with a pulse width of 90% indicates maximum torque.

Exhaust brake

Activation

The exhaust brake¹ is not controlled by the driver but by the control unit.

The working parts of the auxiliary brake i.e. the exhaust brake and the retarder, have different effects at different speeds. On the basis of the road speed, the control unit can decide how to achieve optimum braking and then activate the exhaust brake, retarder or both.

One condition for the activation of the exhaust brake by the retarder control unit is that the main exhaust brake switch (applies only to certain vehicles) on the instrument panel is on.

The exhaust brake is activated:

- if the brake torque requested from the hand lever exceeds 2700 Nm.
- if the control unit is configured for automatic exhaust brake and the requested brake torque from the brake pedal sensor exceeds 500 Nm.
- if the downhill speed control regulator integrated in the control unit requests exhaust braking.

The control unit sends the output signal from pin 17 to the exhaust brake or to the exhaust brake control unit EEB.

1. Some buses are not equipped with exhaust braking.

Disengagement

The exhaust brake is disengaged as follows:

- if the clutch pedal is depressed.
- if the accelerator pedal is depressed.
- if the engine speed drops below 800 - 900 rpm; this is done in order to reduce exhaust emissions.
- if the PWM signal from the EDC is greater than 15%; this indicates a certain throttle position.
- if the ABS/EBS is active.
- if there is a fault in the ABS/EBS system, exhaust braking requested via the brake pedal will be interrupted, which is a legal requirement. The exhaust brake can however, be activated using the hand lever or a retrofitted floor switch.

EEB

The EEB has an electronic control unit for control of the exhaust brake and an automatic function for the white smoke limiter. With EEB and proportional valve V1 a stepless utilisation of the exhaust brake is achieved, as opposed to EXB with solenoid valve and automatic retarder operation.

Retarder with Opticruise and EEB has a floor switch for manual activation of the exhaust brake.

When activated, the chain of events can be different depending on how long the floor switch is kept depressed. The signal is applied to pin 51. Depressing the switch momentarily sends a signal from pin 54 to the Opticruise control unit requesting Opticruise engine brake program. If the pedal is depressed for a longer period, the signal is sent to pin 54 and pin 17 and then on to the exhaust brake control unit.

MBP output

The control unit is equipped with a special output, MBP, at pin 54. MBP is the Swedish abbreviation for engine brake program.

The MBP output is intended for communication with the Opticruise control unit. The function of the MBP output is to request the Opticruise to change down earlier and at a higher engine speed than normal, in order to maintain high coolant flow and so increase the length of time the retarder can be used.

The MBP output is activated as follows:

- if retarder torque exceeds 450 Nm whilst the coolant temperature exceeds 90°C and engine speed drops below 1400 rpm.
- if the torque requested torque using the hand lever exceeds 2700 Nm whilst the actual brake torque exceeds 450 Nm.
- if the exhaust brake floor switch is activated.
- if the brake torque exceeds 450 Nm whilst downhill speed control is engaged and the expected propeller shaft speed is exceeded by 125 rpm.

Warming up the driver and passenger compartments

The retarder can be used to warm up the interior of the vehicle. This is very useful during cold weather, especially in buses

The warm-up function is used in two different ways, depending on whether or not the vehicle has ABS/EBS. It works as follows.

Vehicles with ABS/EBS

Warm-up can only be activated if the coolant temperature is below 70°C when the starter voltage is switched on.

The maximum available power calculated in kW is halved until the coolant reaches 50°C.

The warm-up function is automatically interrupted when the coolant reaches 85°C.

Vehicles without ABS/EBS

Vehicles without ABS/EBS do not have any automated operation of warm-up. Warm-up is achieved simply by applying the accelerator and retarder braking with the lever simultaneously. In principle, it is normal control unit regulation which limits how long warm-up can continue, but the temperature inside the vehicle reaches a comfortable level long before this. See the graph under the heading Limiting at high temperatures.

The maximum available power calculated in kW is halved until the coolant reaches 50°C.

Configuration

General

The control unit contains all the computer programs necessary for all trucks and buses.

The control unit must be **configured** so that it uses the **correct** computer program for the relevant Scania vehicle. This is simply the equivalent of the code plug fitted to other, less modern control units, e.g. for CAG, CS and Scania automatic gearboxes.

Note: Incorrect configuration will always result in reduced performance and/or service life.

The required control unit configuration is entered using a PC during manufacture. As a **spare part** however, the auxiliary brake control unit is only delivered configured for **trucks with ABS**, which is the most common configuration.

If necessary, the configuration can be changed using a PC and Scania Programmer, which is available on CD-ROM. The standard configuration for the vehicle concerned must be used in all but exceptional circumstances. This is described in greater detail under the heading, Configuration, explanations.

The configuration can also be read without a PC, in the form of a configuration code, a so called flashing code, from the diagnostic lamp 2 which is marked RET.

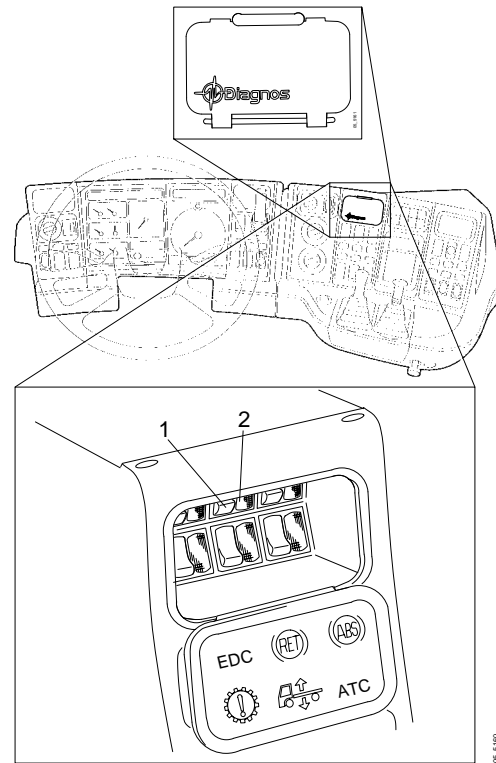

Old type of diagnostics panel up to 9910

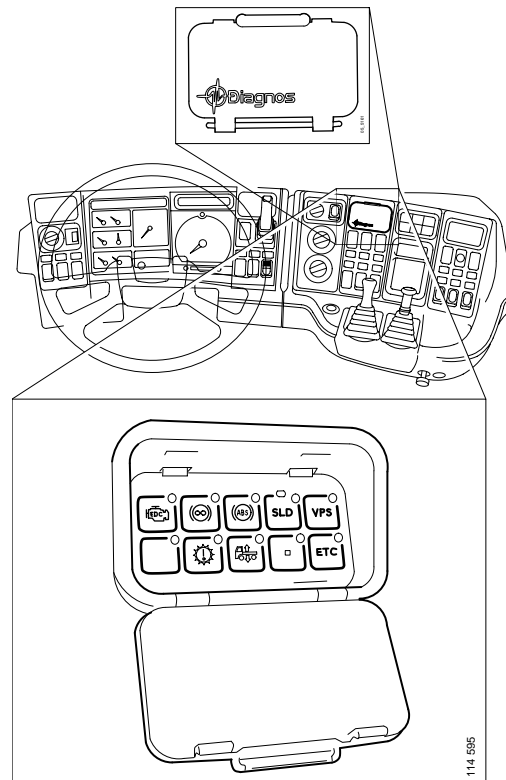

New type of diagnostics panel from 9911

Configuration codes

Control units up to 9911

The configuration codes consist of 3 digits. The digits are flashed out as follows:
1st digit - 1.5 s pause - 2nd digit - 1.5 s pause - 3rd digit - 4.5 s pause, end. After that follow any fault codes.



Standard versions:

Trucks equipped with ABS/EBS have configuration code 468.



Trucks without ABS/EBS have 453.

Buses equipped with ABS have 458 (438 for earlier versions).



Buses without ABS have 453.

Control units from November 1999

Vehicles built from 9911 have a new retarder control unit with one more configuration digit. The following can be configured using this fourth digit:

- Brake torque via CAN, (from EBS version 2.2 onwards).
- Engine fan control.

Note: This type of control unit is introduced as a spare part for both trucks and buses from 9911. However, buses must not be configured with EBS CAN. If a bus is found to be configured with "Brake torque via CAN (from EBS version 2.2 onwards)", trouble shooting should begin immediately and the control unit be reprogrammed using Scania Programmer.

The digits are flashed out as follows:
1st digit - 1.5 s pause - 2nd digit - 1.5 s pause - 3rd digit - 1.5 s pause - 4th digit - 4.5 s pause, end. After that follow any fault codes.



Standard versions:

Trucks equipped with ABS have configuration code 4681.

Trucks with EBS via CAN have configuration code 4682.

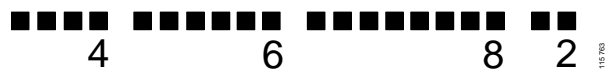

Trucks without ABS/EBS have 4531.

Buses with ABS have 4581.



Buses without ABS have 4531.

Significance of configuration codes

First digit^a	
1	Max. retarder torque 2400 Nm, of which 1500 Nm before the wheel brakes are applied
2	Max. retarder torque 3000 Nm, of which 1500 Nm before the wheel brakes are applied
3	Max. retarder torque 2400 Nm, of which 2000 Nm before the wheel brakes are applied
4	Max. retarder torque 3000 Nm, of which 2000 Nm before the wheel brakes are applied

Second digit	
1	Without automatic downhill speed control, 300 kW retarder power
2	With automatic downhill speed control, 300 kW retarder power
3	Without automatic downhill speed control, 400 kW retarder power
4	With automatic downhill speed control, 400 kW retarder power
5	Without automatic downhill speed control, 500 kW retarder power
6	With automatic downhill speed control, 500 kW retarder power
7	Without automatic downhill speed control, the retarder power is controlled automatically
8	With automatic downhill speed control, the retarder power is controlled automatically

Third digit	
1	Without hand lever control, without brake pedal control, without manual downhill speed control
2	Without hand lever control, with brake pedal control, without manual downhill speed control
3	With hand lever control, without brake pedal control, without manual downhill speed control
4	With hand lever control, with brake pedal control, without manual downhill speed control
5	Without hand lever control, without brake pedal control, with manual downhill speed control
6	Without hand lever control, with brake pedal control, with manual downhill speed control

Third digit	
7	With hand lever control, without brake pedal control, with manual downhill speed control
8	With hand lever control, with brake pedal control, with manual downhill speed control

Fourth digit ^b	
1	Without Brake torque via CAN, from EBS version 2.2, without Engine fan control.
2	With Brake torque via CAN, from EBS version 2.2, without Engine fan control.
3	-
4	-
5	With Engine fan control, without Brake torque via CAN.
6	With Engine fan control, with Brake torque via CAN, from EBS version 2.2.

a: Control units on trucks built from 9911 may have configuration Brake torque via CAN, from EBS version 2.2 onwards. The application of wheel brakes and retarder is then controlled entirely by EBS when the brake pedal is activated, and therefore no brake pedal characteristics are configured for these vehicles. This type of control unit is introduced as a spare part for both trucks and buses from 9911.

b: Vehicles built from 9911 have a new retarder control unit with one more configuration digit. This type of control unit is introduced as a spare part for both trucks and buses from 9911. The control unit should only be configured according to the table, if other configurations are present, this must be changed using Scania Programmer.

Configuration, explanations

Configuring the control unit instead of using a range of different code plugs simplifies both management of parts and any modifications to the vehicle in question. Modifications may be as simple as swapping the standard alternator for a more powerful one, with a different number of terminals and/or gear ratio. Modifications must always be carried out after careful consideration. Configuration must then be checked and updated.

The control unit must always have the correct and complete information¹. Otherwise, it will not be able to perform its tasks in the correct manner.

Never attempt to improve the performance of the auxiliary brake system yourself, by experimenting with the configuration. Each standard configuration has been developed using the collective expertise of Scania in order to achieve the best combination of braking capacity, running costs and ride comfort.

The configuration governs, among other things, the following:

- **Which controls** can be used to operate the auxiliary brake system.
- Whether **downhill speed control** is to be included and if so, how this should be operated. Applies only to vehicles with ABS/EBS.
- **The maximum power of the retarder calculated in kW**. The power must be limited to the maximum amount of heat which can be dissipated by the vehicle's ordinary cooling system.
- **The maximum torque of the retarder calculated in Nm**. It is of course desirable for vehicles with a high gross weight to have high brake torque, but the torque must be limited to a level which the central gear can tolerate without causing premature wear.

¹.By information we mean everything from software and input signals to correct configuration.

- **Brake pedal characteristics**, i.e. how hard the retarder brakes before the wheel brakes are applied. This is normally 2000 Nm for both buses and trucks. Trucks manufactured from 9911 may have the configuration Brake torque via CAN, from EBS version 2.2 onwards. For these vehicles, no brake pedal characteristics are configured.
- Available **cooling capacity** in the cooling system. Alternator frequency must be correctly specified or the control unit will miscalculate the engine speed and thus coolant flow at any given time. Incorrect data can for example cause problems with overheating or unnecessarily low retarder power.
- **Communication with EBS via CAN** is introduced on trucks from 9911. The configuration Brake torque via CAN, from EBS version 2.2 onwards, is therefore selected. Application of the wheel brakes and retarder is fully controlled by EBS when the brake pedal is depressed.
- **Retarder control of the engine fan** is introduced on certain engine types in trucks from 0005. When the configuration "Engine fan control" is selected, the retarder control unit will send CAN messages with the desired engagement level of the engine fan to the EDC control unit. The engagement level depends on the coolant temperature.

The above can be a guide in such cases where a certain fault is suspected as being caused by incorrect configuration.

Control unit as spare part

Every control unit from our parts department is configured for trucks with ABS. In such vehicles, and only there, the control unit may be used as delivered. Otherwise, the configuration must be changed using a PC and Scania Programmer, which is available on CD-ROM.

Function	Standard setting as spare part	Alternative
Operation with brake pedal	yes	yes / no
Operation with hand lever	yes	yes / no
Manual activation of downhill speed control	yes	yes / no
Automatic activation of downhill speed control	yes	yes / no
Automatic activation of exhaust brake ^a	no	yes / no
Retarder version ^b	00	00
Retarder power	500 kW	300 / 400 / 500 kW
Retarder torque	3000 Nm	2400 / 3000 Nm
Brake pedal characteristics ^c	2000 Nm	1500 / 2000 Nm
Compensation of current to the proportional valve ^d	0 mA.	+/- 50 mA
Alternator frequency (Truck, 6 poles) at engine speed 500 rpm	172 Hz	100 - 255 Hz
Alternator frequency (Bus, 8 poles) at engine speed 500 rpm	200 Hz	100 - 255 Hz
Alternator frequency (Truck, 8 poles, 90 A) at engine speed 500 rpm	230 Hz	100 - 255 Hz
Communication with EBS via CAN ^e	no	yes / no
Communication with EDC via CAN, engine fan control	no	yes / no

a: Certain buses have no exhaust brake at all.

b: Applies to the construction and design of the actual retarder.

c: Trucks built from 9911 may have the configuration Brake torque via CAN, from EBS version 2.2 onwards. For these vehicles, no brake pedal characteristics are configured.

d: Poor braking power during the initial stage or jerky downhill speed control on gentle downhill slopes may be an indication that the current intensity needs to be adjusted. Too low and too high current intensity can both cause jerky downhill speed control. The reason for this is that there are a whole series of tolerances that must tally in order to give the required comfort, from current to compressed air and from mechanical precision to oil pressure. Any adjustments may only be made under exceptional circumstances and then only slight adjustments, e.g. 5 mA at a time.

e: From 9911, the retarder control unit communicates using CAN communication with the EBS control units and from 0005 with EDC control units (applies only to trucks). This retarder control unit that supports this communication is introduced as a spare part for both trucks and buses from 9911.

Control unit connections

The table below shows which input signals the control unit can receive and which pin is used for which signal.

Most, but not all, input signals are in the form of a positive voltage.

The * symbol beside the pin number indicates that the input signal in question is activated when the control circuit is earthed.

Control unit input signals

Pin	Input signal
8	Hand lever position
12	PWM signal from EDC.
13*	Accelerator pedal switch
14*	ABS/EBS reports ABS/EBS fault. For trucks with retarder configuration Brake torque via CAN, from EBS version 2.2 onwards, the signal ABS/EBS fault is sent to the retarder as a CAN message. The CAN cables are connected to pins 39 and 40, see Other connections.
16	Propeller shaft speed, i.e. current road speed
23	Brake pedal position. The input signal is not used for trucks with retarder configuration Brake torque via CAN, from EBS version 2.2 onwards; instead, in these vehicles the EBS control unit sends the required retarder brake torque via CAN. The CAN cables are connected to pins 39 and 40, see Other connections.
25	Temperature sensor 1
30*	Diagnostics switch
31	AUT switch for automatic activation of downhill speed control.
32*	Switch for manual activation of downhill speed control
33*	Exhaust brake switch on instrument panel
34	Engine speed, i.e. current cooling capacity.
35*	ABS/EBS announces ABS control. For trucks with retarder configuration Brake torque via CAN (from EBS version 2.2 onwards) the signal ABS control is sent to the retarder as a CAN message. The CAN cables are connected to pins 39 and 40, see Other connections.
43	Temperature sensor 2
50*	Clutch pedal switch
51	Foot-operated switch for exhaust brake, not standard equipment

The table below shows which output signals the control unit can send and which terminal pin is used for which signal.

Earthing points, power supplies etc. are covered under the heading Other connections.

Most, but not all, output signals are activated by a positive voltage in the control circuit.

The * symbol beside the pin number indicates that the output signal is instead activated by the control circuit being earthed.

Control unit output signals

Pin	Output signal
2	Proportional valve (+) for torque control of the retarder
17	Solenoid valve (or control unit) for exhaust brake
18	Request to EDC for disengagement of cruise control.
30*	Retarder diagnostic lamp on instrument panel
36	RET warning lamp on instrument panel
38	Proportional valve (-) for torque control of the retarder
52	Solenoid valve for oil accumulator
53	Solenoid valve for compressed air supply
54	Request for engine braking program, MBP
55*	Stop light relay

Other connections

Pin	Connections
1	System earth (0 V)
4	Brake pedal sensor (-)
6	Temperature sensor 1 (-)
7	Temperature sensor 2 (-)
15	L cable, diagnostic socket
37	System voltage (24 V)
19	System voltage (24 V)
20	System earth (0 V)
26	Hand lever sensor (-)
39	Communication cable, CAN LOW. Dependant upon how the retarder control unit is configured and how the truck is equipped, this cable is used for communication with EBS, from EBS version 2.2 onwards, and EDC.
40	Communication cable, CAN HIGH. Dependant upon how the retarder control unit is configured and how the truck is equipped, this cable is used for communication with EBS, from EBS version 2.2 onwards, and EDC.
41	Brake pedal sensor (+)
44	Hand lever sensor (+)
49	K cable, diagnostic socket

Warning system

General

Introduction

If any faults arise, the control unit will initiate a variety of measures. This is to prevent the fault causing expensive damage.

If a fault occurs, the control unit will also light the warning lamp (RET) on the instrument panel. If the fault ceases, the warning lamp usually goes out by itself. This is not always the case and depends on the nature of the fault.

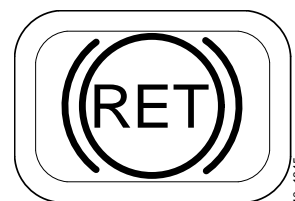

The lamp should come on for a second every time the ignition is turned on (test).

Certain types of fault disable downhill speed control, for instance, or make it impossible to use the brake pedal to initiate downhill speed control. However, the lever usually still works even when such faults have developed. The reason may be a fault in the ABS/EBS system, for example, and in such a case the ABS/EBS lamp should come on.

The vehicle must get up to speed for the ABS/EBS lamp to go out. Before this, the RET lamp cannot go out either, in case the fault is one which concerns auxiliary brake and ABS/EBS interaction.

Resetting of the warning system is carried out on two levels. The flashing codes are erased and the warning lamp goes out. Fault codes that are read using a PC can only be erased using a PC. This is described under the heading Final erasure of fault codes using a PC.

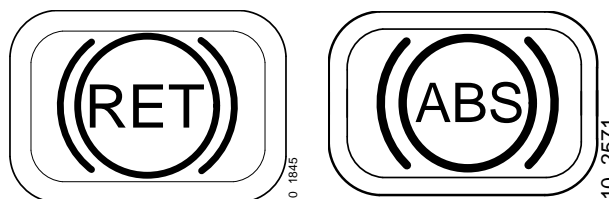

Why fault codes are generated

The control unit reacts quickly and according to certain instructions. In practice, the control unit works with long series of conditions, signals, routines and commands that continuously succeed each other.

When the control unit discovers a fault, or something which it interprets as abnormal, it immediately reacts and generates a fault code. The warning system can generate about 40 different fault codes depending on the nature of the fault. Fault codes are generally very accurate.

Limitations

Despite the advanced software, a fault may arise which the control unit is unable to distinguish from something which may occur under normal operation. If this is the case, no fault code is generated. There is always a limit to how complete the monitoring can be. The above applies to all types of control units.

Warning lamp, fault indication

Warning lamp

If the fault ceases, the warning lamp will generally go out automatically. This may seem coincidental to some drivers, but has of course functional or safety reasons.

More information on reasons for fault codes can be found in SD and in the work description for trouble shooting.

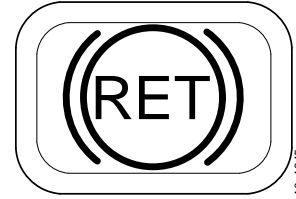

Resetting the warning system

General

The warning system may occasionally need resetting. Someone may have, for example disconnected a cable harness whilst the ignition was turned on. This is quite a common occurrence. The control unit will then interpret it as a fault. This will also illuminate the warning lamp RET.

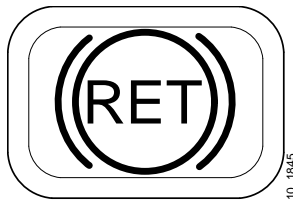

10 1845

Resetting of the warning system is carried out at two levels and is described below.

Erasing flashing codes

This extinguishes the RET warning lamp and erases the flashing codes shown by the diagnostic lamp 2. The fault codes will however remain in another memory that can only be accessed using a PC, see Final erasure of fault codes using a PC.

- 1 Press in the switch 1 and keep it depressed.

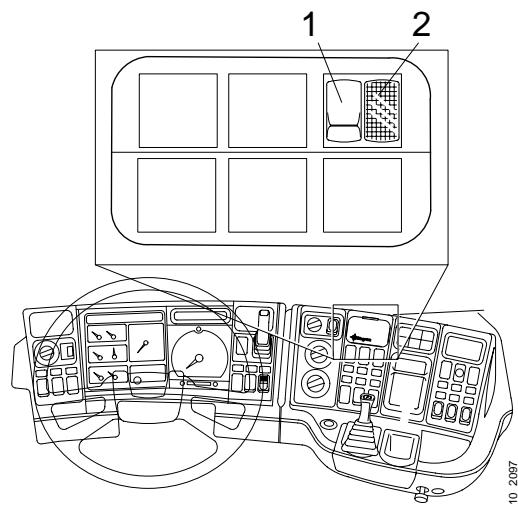

10 2087

Old version of diagnostic panel up to and including 9910

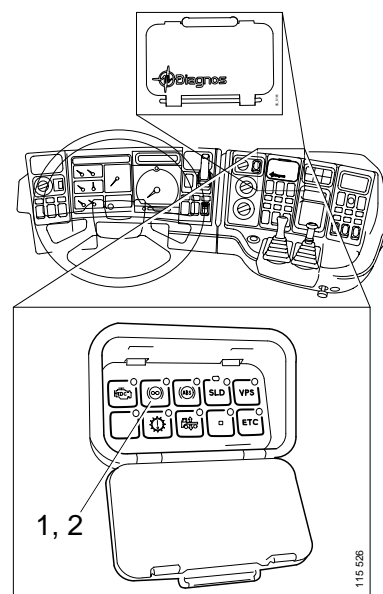

115 528

New version of diagnostic panel from 9911

- 2 Turn the starter key to the drive position and wait at least 3 seconds. The resetting is now complete.
- 3 Drive the vehicle and check that the ABS and RET lamps go out. If they don't, or if the RET lamp illuminates again, despite repeated resetting, then a fault remains. If so, carry out trouble shooting of the system, preferably using SD and a PC.

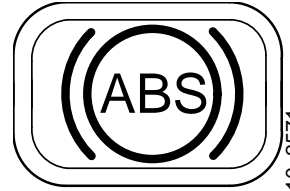
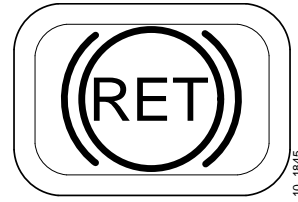

Final erasure of fault codes using a PC.

Fault codes are stored in the order they are registered. How many times a fault has occurred can also be seen. This can be of use for example with sporadic malfunctions¹.

After completion of trouble shooting the fault codes should be finally erased using a PC and the command Erase fault codes.

¹.That the diagnostic lamp's flashing codes have been erased makes no difference.