

12:03-02

SCANIA

Issue 1 en

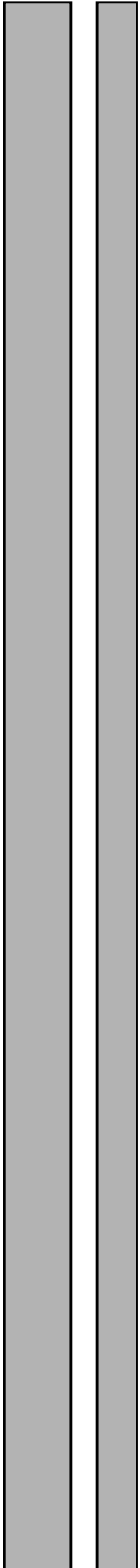

Electronic level control ELC 6x2 B

Work description

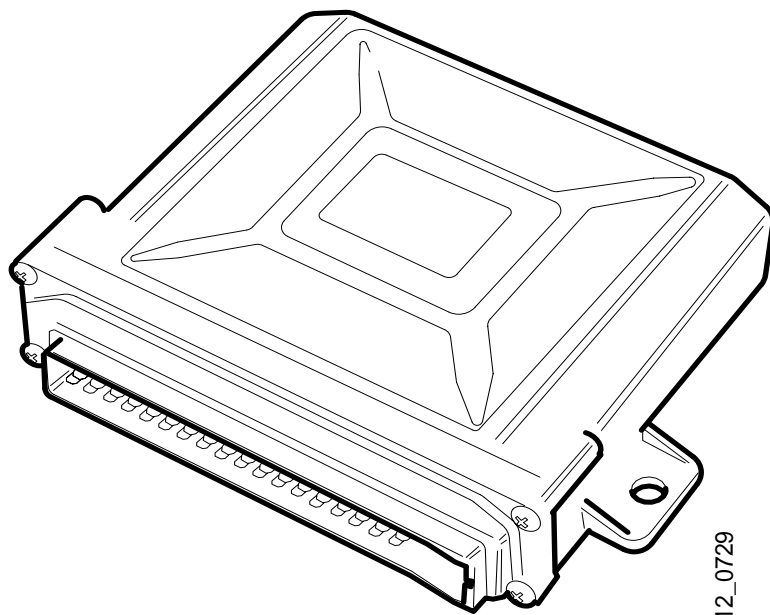

12_0729

Contents

Introduction	Important3
	Safety3
Fault diagnosis	Introduction5
	System faults6
Diagnostic feature	Reading flashing codes7
	Erasing fault codes8
Fault codes	Fault codes 01-62 9-22
Input signals	Pressure monitors23
	Level sensors24
	Fitting level sensor25
Changing control unit	Configuring27
	Calibration27
Level calibration	Levels28
	Calibration29
Compressed air components	Component information30
	Skeleton diagrams31
Wiring diagrams	Component information32
	Wiring diagrams 33-35

Introduction

Important

This work description covers the ELC control unit 6x2:

Scania part No. **1 374 465**

Safety



Always use stands when working under vehicles with air suspension.

Working under vehicles with air suspension should be carried out in such a way as to avoid the risk of injury. If the frame falls onto the axle it may cause crushing or blow injuries.

The frame falls onto the axle if:

- an air bellows is punctured
- an air line is disconnected
- power is applied to a valve for venting the bellows
- a level sensor is changed when starter voltage is on.

Fault diagnosis

Introduction

ELC continuously checks its own operation. If there is a fault, this is indicated with the system fault lamp. Any faults discovered will be given a fault code and stored in the control unit. Fault codes can then be read as a flashing code on the diagnostic lamp.

Faults which can be revealed by the control unit:

- Short circuit in wiring, sensors and solenoid valves.
- Breaks in wiring, sensors and solenoid valves.
- Incorrect control function (the control unit is unable to raise or lower the chassis to the required level).
- Fault in control unit memory.

When a fault has arisen and been registered, this will be indicated with the system fault lamp. The fault is given fault code which is stored in the control unit.

The system fault lamp also comes on:

- If the ignition is switched on. The lamp flashes to show that it working. No fault code is generated.
- Level calibration is ended. No fault code is generated.
- If the voltage supply to the control unit is too low between 5 and 18 volts. No fault code is generated. If voltage supply is below 5 volts, the control unit is switched off entirely.

Faults which cannot be revealed by the control unit:

- Faults in the control box.
- Breaks in wiring for speed signal. The control unit will not change control from fast control to normal control when the vehicle starts moving.
- Break in brake signal cable. The control unit does not stop control during braking.

- Bent lever/link to level sensor. This fault will give incorrect drive level.
- Valve for raising/lowering chassis sticking in open position. The chassis is raised and lowered.
- Break in cable to T70 or in the actual pressure monitor (max. driving axle load during tag axle lift). It is not possible to raise the tag axle using switch S105 on the instrument panel.
- Break in both cables to the pressure monitors or in the actual pressure monitors. T70 (max. driving axle load during tag axle lift) and T71 (max. driving axle load during load transfer). It is not possible to raise the tag axle or conduct load transfer using switch S105 on the instrument panel.
- Pressure monitor T70 (max. driving axle load during tag axle lift) and/or T71 (max. driving axle load during load transfer) are activated by incorrect air pressure. This generates a fault code if T70 with lower activation pressure breaks before T71 with higher activation pressure.
- Blocked valve connections for tag axle operation. It is not possible to operate the tag axle
- The pressure monitors and control box are powered from the same fuse as the control unit. If there is a short circuit to earth in any of these components the control unit will cease working.
- If the coil in the level sensor is damaged or there is moisture in the sensor or the sensor switch, truck driving level becomes incorrect.

System faults

If the control unit detects a fault, a warning is provided by the system fault lamp.

Faults are divided into two groups, serious and other faults.

Serious faults

In the case of serious faults, the system fault lamp **flashes** and a fault code is generated. Serious faults are divided into two categories.

Serious faults, category 1:

- ROM malfunction. Fault code generated.
- RAM malfunction. Fault code generated.

Level control ceases and drive levels are locked. If any of these faults arises, try switching off the power and switching it back on again. If the lamp does not stop flashing, the control unit must be changed.

Serious faults, category 2:

- Faults in wiring to level sensors and solenoid valves (short/break). Fault code generated.
- Faults in level sensors and solenoid valves (short circuit/break). Fault code generated.
- Incorrect parameters. Fault code generated.
- Incorrect calibration values. Fault code generated.

Level control ceases and drive levels are locked. It may be possible to adjust the chassis manually using the control box. Try switching the power off and on again.

If the fault is due to a defective contact and corrects itself, the system will return to normal level control. The fault code is stored in the control unit.

Other faults

In the case of less serious faults, the system fault lamp lights **continuously**.

The following is considered as a less serious fault:

- Faulty control feature. Control unit is unable to lower/raise the chassis to desired level. Fault code generated.

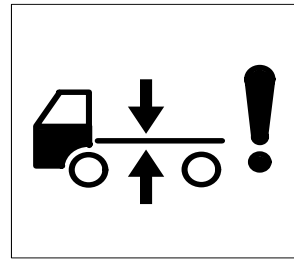

System fault lamp

Level control ceases but can be restarted by switching off the power and switching it back on again.

- Pressure monitor T71 with higher activation pressure is actuated when T70 is unactuated. Fault code generated.

Level control continues but it is not possible to raise the tag axle.

Diagnostic feature

Reading flashing codes

Fault codes are read using flashing codes on the diagnostic lamp on the instrument panel.

- 1 Press the diagnostic switch beside the diagnostic lamp for at least 2 seconds.
- 2 The switch is released and the first fault code is flashed.
- 3 The flashing code consists of tens and units. When the diagnostic switch is released the tens are flashed out first. The flashing signal for tens consists of slow flashes 10, 20, 30 etc. Units are flashed out after the tens. The flashing signal for units consists of quicker flashes, 1, 2, 3, 4 etc.
- 4 The flashing signal is added up to a fault code, which can be read on the fault code list.
- 5 If the diagnostic switch is again depressed the next fault code is flashed out.
- 6 If you wish to read the first flashing code again, power must be switched off and back on again.

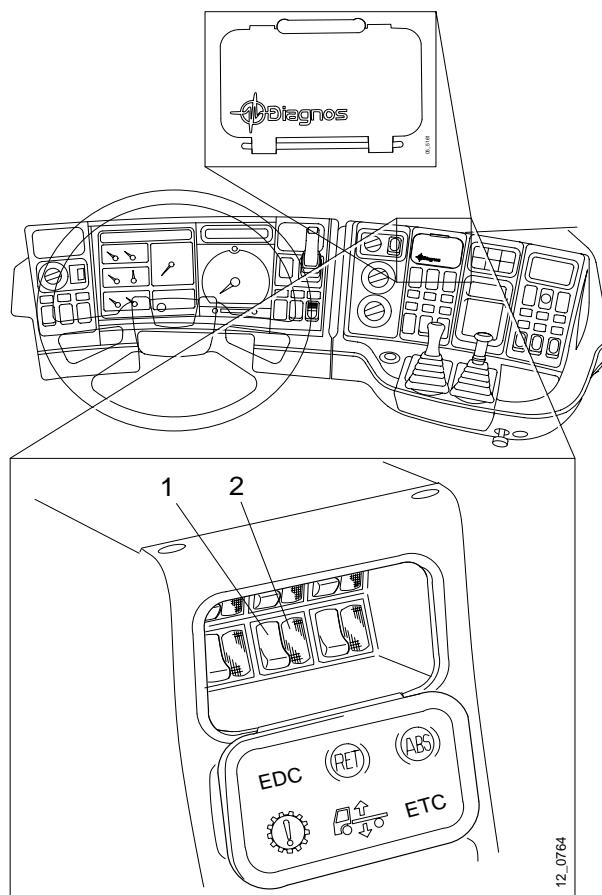

1 Diagnostic switch
2 Diagnostic lamp

No system faults

If there are no faults in the system, no flashing codes can be read.

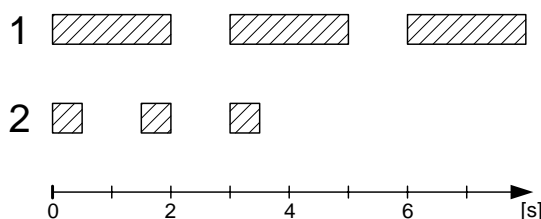

Flashing code for fault code 33.

1 Flashing code, tens
2 Flashing code, units

Erasing fault codes

Fault codes are stored in the control unit until they are erased. It is important to erase fault codes when the fault has been rectified so that they do not cause confusion when fault diagnosis is next carried out.

- 1 Switch off the power using the starter key. Press the diagnostic switch and hold it down.
- 2 Turn the starter key to drive and wait for at least three seconds before releasing the diagnostic switch. Erasure is then completed.
- 3 Start the truck and raise/lower it using the control box. Check that the fault codes are not regenerated.

Fault codes

Fault code 01

Fault: Parameter fault in control unit.

Cause: The test sum of the parameters is not correct. One of the parameters which controls the work process has assumed an incorrect value.

Comment: When programming the parameter list, the binary parameter codes are added together to a figure which is stored in the control unit. The control unit checks the parameter list against this figure and produces a warning if it is incorrect.

Action: Erase fault code. If the fault code is again generated, reprogram the parameters using Scania Programmer 2. If you do not have Programmer 2 change the control unit.

Fault code 02

Fault: Calibration fault in control unit.

Cause: The test sum during calibration is faulty. One of the levels calibrated in the control unit has assumed an incorrect value.

Comments: During calibration the control unit reads three level signals from the level sensor. The binary codes for these levels are added together to give a figure which is stored in the control unit. The control unit then checks the calibration values against this figure.

Action: Erase fault code. Recalibrate drive level, maximum level and lower mechanical stop if it is regenerated.

Fault code 03

Fault: Fault in control unit integrated memory.

Cause: Test sum in ROM incorrect. Data in ROM has assumed an incorrect value.

Comment: When programming the ROM, the contents are added together to a sum which is stored in the control unit. The control unit then continuously checks the ROM against this sum.

Action: Erase fault code. Change control unit if it is regenerated.

Fault code 04

Fault: Fault in control unit integrated memory.

Cause: WABCO data test sum incorrect. WABCO data has assumed an incorrect value.

Comment:

Action: Erase fault code. If the fault code is again generated, reprogram the parameters using Scania Programmer 2. If you do not have Programmer 2 change the control unit.

Fault code 05

Fault: Fault in control unit integrated memory.

Cause: Test sum of adjustment data incorrect. Adjustment data has assumed an incorrect value.

Comment:

Action: Erase fault code. Change control unit if it is regenerated.

Fault code 06

Fault: Fault in control unit integrated memory.

Cause: Incorrect RAM. Control unit RAM is defective.

Comment: When checking the memory cells in the RAM, the control unit has discovered a defective memory cell.

Action: Erase fault code. Change control unit if it is regenerated.

Fault code 07

Fault: Fault in control unit microprocessor.

Cause:

Comment: A fault has been discovered in the microprocessor during an internal reliability test.

Action: Erase fault code. Change control unit if it is regenerated.

Fault code 08

Fault: Pressure monitor T70 (max. driving axle load, tag axle lift) or T71 (max. driving axle load during load transfer) faulty.

Cause: Pressure monitor T70 with the lower activating pressure is closed (unactuated) when pressure monitor T71 with the higher activation pressure is open (actuated).

Comment: This fault code is generated if the fault lasts for longer than 2 seconds.

Action: Empty the air from the air bellows so that the frame is resting on the bump stop. Switch off the power. Measure resistance between pins 6 and 9 on the contact to the control unit. If there is a break (OL on FLUKE) in T71 or wiring, see circuit 57. Check pressure monitor activating pressure. Pressure is marked on the pressure monitor.

Fault code 10 or 11

Fault: Break or short circuit in level sensor on driving axle.

Cause: Break or short circuit to +24 volt in sensor T73 or in wiring from pin 25 on the control unit.

Comment: Control unit receives no information about rear chassis height and cannot work.

Action: Measure the resistance across the contact pin on the sensor. Resistance should be 120 ohm. Check the wiring between the control unit and the sensor. See circuit 63.

Fault code 12

Fault: Break or short to +24 volt in level sensor on front axle.

Cause: Break or short circuit to +24 volt in sensor T72 or in wiring from pin 26 on the control unit.

Comment: Control unit receives no information about front chassis height and cannot work.

Action: Measure the resistance across the contact pin on the sensor. Resistance should be 120 ohm. Check the wiring between the control unit and the sensor. See current circuit 60.

Fault code 20 or 21

Fault: Short to ground in level sensor on driving axle.

Cause: Short circuit to earth in sensor T73 or in wiring from pin 25 on the control unit.

Comment: Control unit receives no information about rear chassis height and cannot work.

Action: Measure the resistance across the contact pin on the sensor. Resistance should be 120 ohm. Check the wiring between the control unit and the sensor. See circuit 63.

Fault code 22

Fault: Short to ground in level sensor on front axle.

Cause: Short circuit to earth in sensor T72 or in wiring from pin 26 on the control unit.

Comment: Control unit receives no information about front chassis height and cannot work.

Action: Measure the resistance across the contact pin on the sensor. Resistance should be 120 ohm. Check the wiring between the control unit and the sensor. See current circuit 60.

Fault code 30

Fault: Loss of function for raising/lowering spring bellows.

Cause: Break or short circuit to +24 volt between pins 2 and 4 in contact to valve V54 or in wiring from pin 15 on the control unit.

Comment: Control unit is unable to operate the front and drive axle bellows.

Action: Measure the resistance between contact pins 2 and 4 on valve V54. Resistance should be 70-80 ohm. Check wiring. See circuit 68.

Fault code 31 or 32

Fault: Loss of function, raising/lowering driving axle.

Cause: Break or short to +24 volt between pins 3 and 4 in valve V54 or in wiring from pin 13 on the control unit.

Comment: The control unit is unable to operate the driving axle bellows and the tag axle bellows.

Action: Measure the resistance between contact pins 3 and 4 on valve block V54. Resistance should be 70-80 ohm. Check wiring. See current circuit 69.

Fault code 33

Fault: Loss of function for emptying lifting bellows and pressurizing spring bellows on tag axle.

Cause: Break or short to +24 volt between pins 1 and 4 in valve V55 or in wiring from pin 12 on the control unit.

Comment: The control unit is unable to provide the tag axle with spring air and is unable to empty the tag axle lifting bellows.

Action: Measure the resistance between contact pins 1 and 4 on valve block V55. Resistance should be 70-80 ohm. Check wiring. See circuit 71.

Fault code 34

Fault: Loss of function for evacuating spring bellows on tag axle.

Cause: Break or short to +24 volt between pins 3 and 4 in valve V55 or in wiring from pin 30 on the control unit.

Comment: The control unit is unable to evacuate the tag axle bellows.

Action: Measure the resistance between contact pins 3 and 4 on valve block V55. Resistance should be 70-80 ohm. Check wiring. See current circuit 73.

Fault code 36

Fault: Loss of function, raising/lowering front axle.

Cause: Break or short to +24 volt between pins 1 and 4 in valve V54 or in wiring from pin 11 on the control unit.

Comment: Control unit is unable to operate the front axle.

Action: Measure the resistance between contact pins 1 and 4 on valve block V54. Resistance should be 70-80 ohm. Check wiring. See circuit 67.

Fault code 37

Fault: Loss of function for raising tag axle.

Cause: Break or short to +24 volt between pins 2 and 4 in valve V55 or in wiring from pin 14 on the control unit.

Comment: The control unit is unable to fill the air bellows for the tag axle.

Action: Measure the resistance between contact pins 2 and 4 on valve block V55. Resistance should be 70-80 ohm. Check wiring. See circuit 72.

Fault code 40

Fault: Loss of function for raising/lowering spring bellows.

Cause: Short circuit to earth between pins 2 and 4 in valve V54 or in wiring from pin 15 on the control unit.

Comment: Control unit is unable to operate front axle bellows and tag axle bellows.

Action: Measure resistance across contact pins 2 and 4 on valve block V54. Resistance should be 70-80 ohm. Check wiring. See circuit 68.

Fault code 41 or 42

Fault: Loss of function, raising/lowering driving axle.

Cause: Short circuit to earth between pins 3 and 4 in valve V54 or in wiring from pin 13 on the control unit.

Comment: Control unit is unable to operate the driving axle bellows or tag axle bellows.

Action: Measure resistance across contact pins 3 and 4 on valve block V54. Resistance should be 70-80 ohm. Check wiring. See current circuit 69.

Fault code 43

Fault: Loss of function for emptying lifting bellows and pressurizing spring bellows on tag axle.

Cause: Short circuit to earth between pins 1 and 4 in valve V55 or in wiring from pin 12 on the control unit.

Comment: The control unit is unable to provide the tag axle with spring air and is unable to empty the tag axle lifting bellows.

Action: Measure the resistance between contact pins 1 and 4 on valve block V55. Resistance should be 70-80 ohm. Check wiring. See current circuit 72.

Fault code 44

Fault: Loss of function for evacuating spring bellows on tag axle.

Cause: Short circuit to earth between pins 3 and 4 in valve V55 or in wiring from pin 30 on the control unit.

Comment: The control unit is unable to evacuate the tag axle bellows.

Action: Measure the resistance between contact pins 3 and 4 on valve block V55. Resistance should be 70-80 ohm. Check wiring. See current circuit 73.

Fault code 46

Fault: Loss of function, raising/lowering front axle.

Cause: Short circuit to earth between pins 1 and 4 in valve V54 or in wiring from pin 11 on the control unit.

Comment: Control unit is unable to operate the front axle.

Action: Measure resistance across contact pins 1 and 4 on valve block V54. Resistance should be 70-80 ohm. Check wiring. See circuit 67.

Fault code 47

Fault: Loss of function for raising tag axle.

Cause: Short circuit to earth between pins 2 and 4 in valve V55 or in wiring from pin 14 on the control unit.

Comment: The control unit is unable to fill the air bellows for the tag axle.

Action: Measure the resistance between contact pins 2 and 4 on valve block V55. Resistance should be 70-80 ohm. Check wiring. See circuit 72.

Fault code 50 or 51

Fault: Unsatisfactory control when raising the rear of the chassis.

Cause: Rear level sensor has, for 30 seconds, given a level signal which is lower than the level to which the control unit is attempting to adjust the vehicle.

Comment: Fault code cannot be generated until at least 15 minutes after the starter power is switched on.

This is in order to ensure that there is sufficiently high system pressure in the compressed air system.

Action: Check air pressure. Check that air is reaching the bellows, look for leakage, blocked air lines and seizing valves. Check that the sensor link and lever have not been bent or become detached.

Fault code 52

Fault: Unsatisfactory control when raising the front of the chassis.

Cause: The level sensor has, for 30 seconds, been giving a level signal which is lower than that to which the control unit is attempting to adjust the vehicle.

Comment: Fault code cannot be generated until at least 15 minutes after the starter power is switched on.

This is in order to ensure that there is sufficiently high system pressure in the compressed air system.

Action: Check air pressure. Check that air is reaching the bellows, look for leakage, blocked air lines and seizing valves. Check that the sensor link and lever have not been bent or become detached.

Fault code 60 or 61

Fault: Unsatisfactory control when lowering the rear of the chassis.

Cause: The rear level sensor has, for 30 seconds, been providing a level signal which is higher than that level to which the control unit is attempting to adjust the vehicle.

Comment: Fault code cannot be generated until at least 15 minutes after the starter power is switched on.

Action: Look for blocked air lines. Check if the sensor link or lever has become bent or detached. Check if the valve is seizing in raising position. Check that there is nothing mechanical preventing lowering.

Fault code 62

Fault code 62

Fault: Unsatisfactory control when lowering the front of the chassis.

Cause: The level sensor has, for 30 seconds, been giving a level signal which is higher than that level to which the control unit is attempting to adjust the vehicle.

Comment: Fault code cannot be generated until at least 15 minutes after the starter power is switched on.

Action: Look for blocked air lines. Check if the sensor link or lever has become bent or detached. Check if the valve is seizing in raising position. Check that there is nothing mechanical preventing lowering.

Input signals

Pressure monitors

Function

The pressure monitors are connected to the driving axle bellows.

When pressure monitor T70 (max. driving axle load during tag axle lift) breaks and switch S105 is in its intermediate position (tag axle lift), the tag axle will be lowered.

If switch S105 is set to its upper position (load transfer), the tag axle bellows will be evacuated. When pressure monitor T71 (max. driving axle load during load transfer) breaks, evacuation of the tag axle bellows will be interrupted.

Changing

When changing pressure monitors, the new pressure monitor must have the same activation pressure as the old one so that load transfer is not affected.

Sensor activation pressure is given on the pressure monitor.

Fault diagnosis

The pressure monitors work as circuit breakers.

The pressure monitors are powered via fuse 10. If a pressure monitor is shorted to earth and the fuse blows, power supply to pin 9 on the control unit will also disappear.

See wiring diagrams, circuits 51-58

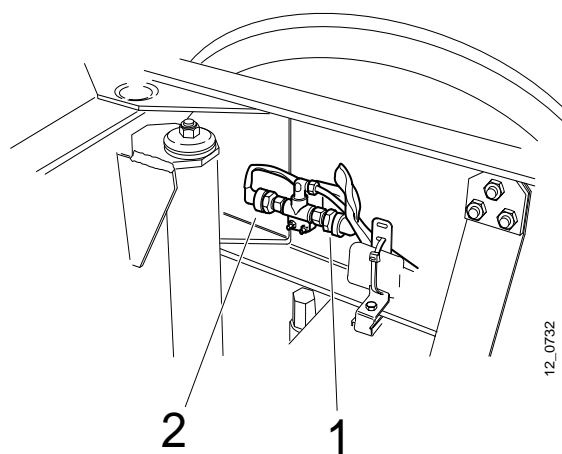

The pressure monitors are located on the left-hand side of the frame above the tag axle

1 Pressure monitor T70 (max. drive axle weight during tag axle lift)

2 Pressure monitor T71 (max. drive axle weight during load transfer)

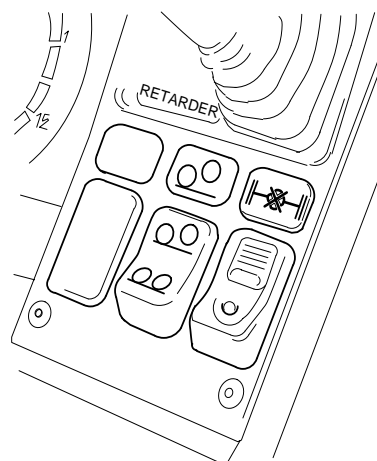

Switch S105 in load transfer position

Level sensors



WARNING!

When changing level sensors the truck starter power should be switched off. If the power is switched on the control unit will start to control level as soon as an operational sensor has been connected. This can cause crushing injury.

Changing

When changing level sensors, the rotating lever bracket should be turned as illustrated in figures 3 and 4 so that the sensor works correctly.

The front axle lever bracket is turned as illustrated in figure 3.

The rear axle lever bracket is turned as illustrated in figure 4.

In addition, level calibration must be done in the control unit. See "Level calibration" on page 29.

Fault diagnosis

Level sensors are of inductive type.

During fault diagnosis it is not possible to measure any change in resistance when the sensor is actuated.

Sensor coil resistance will be constant irrespective of how the rotating bracket on the sensor is turned.

Coil resistance is 120 ohm.

Incorrect coil resistance can be due to sensor damage or moisture in the sensor or sensor switch. This will give incorrect driving level.

If the sensor lever or link has been bent or detached, truck driving level will be incorrect.

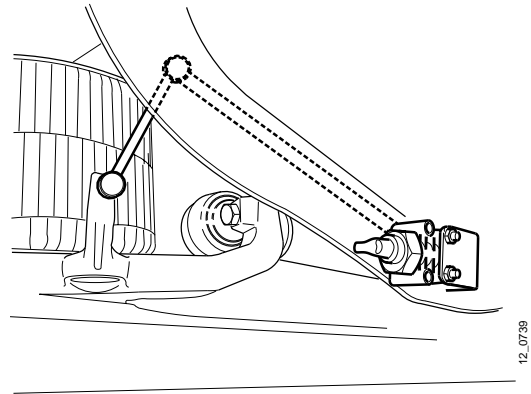

12_0739

Fig. 1 The front level sensor is located on the crossmember under the gearbox.

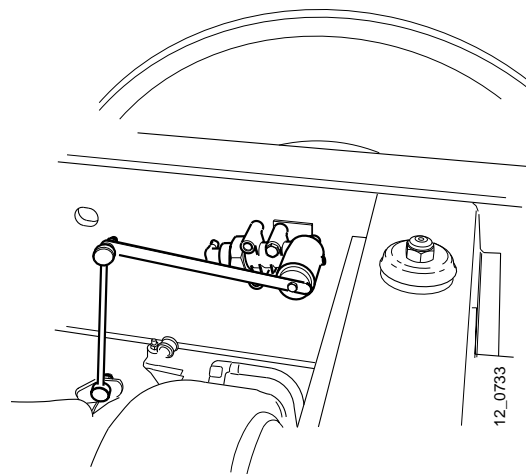

12_0733

Fig. 2 The rear level sensor is located on the right-hand side of the frame above the drive axle.

Fitting level sensor

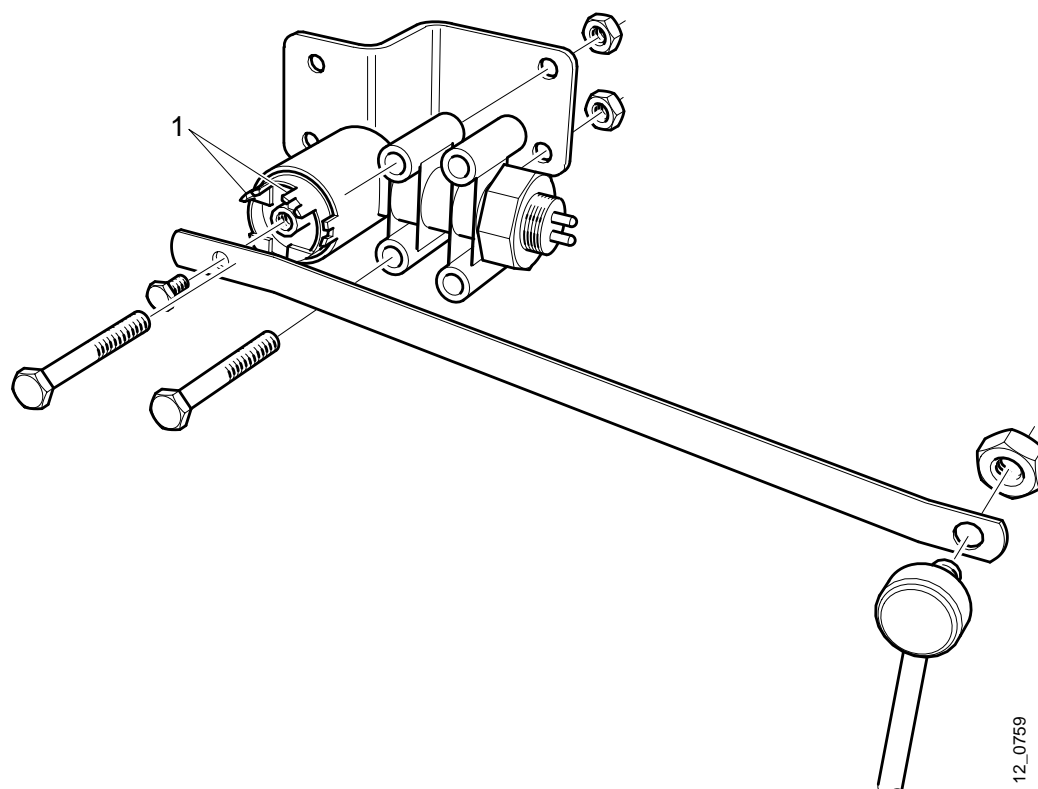

*Fig. 3 Fitting level sensor for front axle. **N.B.** The raised lugs (1) on the rotating bracket are turned up in order to achieve correct sensor operation.*

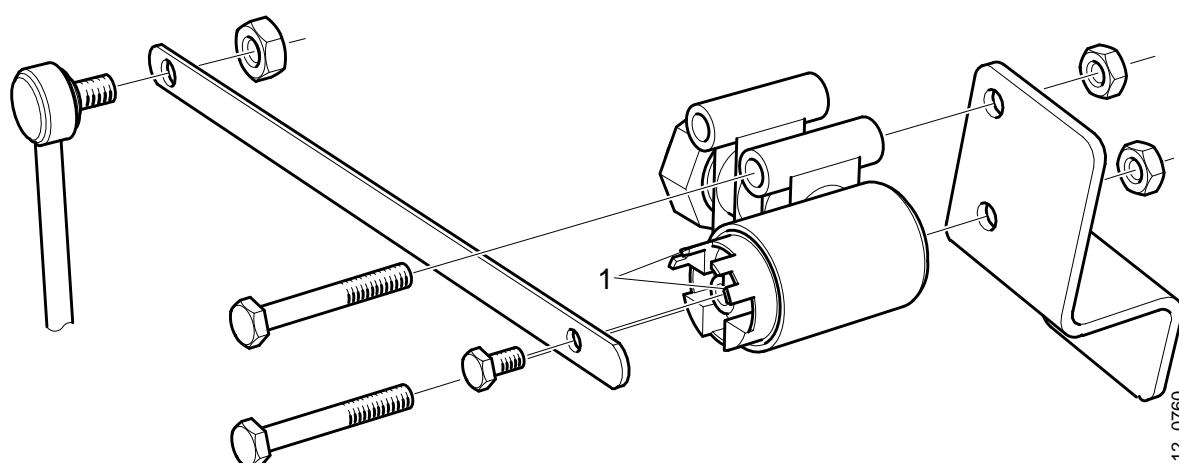

*Fig. 4 Fitting level sensor for drive axle. **N.B.** The raised lugs (1) on the rotating bracket are turned up in order for the sensor to operate correctly.*

Changing control unit

Configuring

When the control unit is changed, the new control unit should be configured for the vehicle. The control unit is supplied from Scania with correct basic configuration.

Type of load transfer feature, time limited or not time limited is sensed by the control unit when connected.

Calibration

When changing control units and level sensors, level sensors should be calibrated for the new control unit. See page 29.

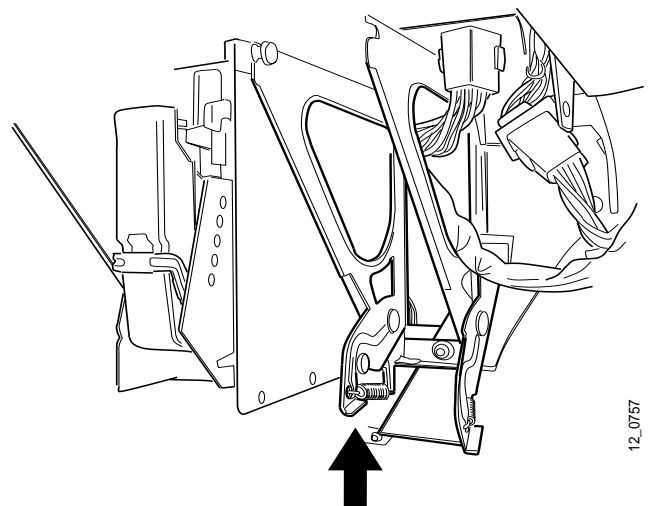
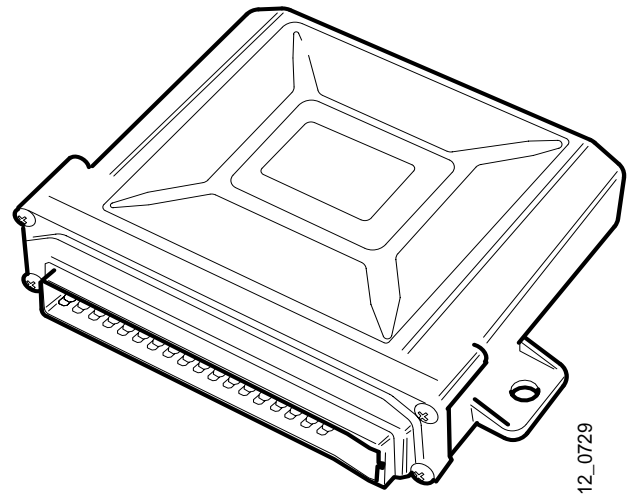

The control unit is removed by pushing up the attaching clamp and unplugging it.

Level calibration

Levels

When changing control unit and level sensors, three levels should be calibrated in the control unit.

Driving level-the level at which the vehicle is normally driven.

Max. level- the highest level which can be permitted. If the chassis is raised too much the bellows or shock absorbers may be damaged.

Lower mechanical stop- when the frame bump stop rests against the axle.

The heights given in the table below are measured as in fig 1 and fig 2.

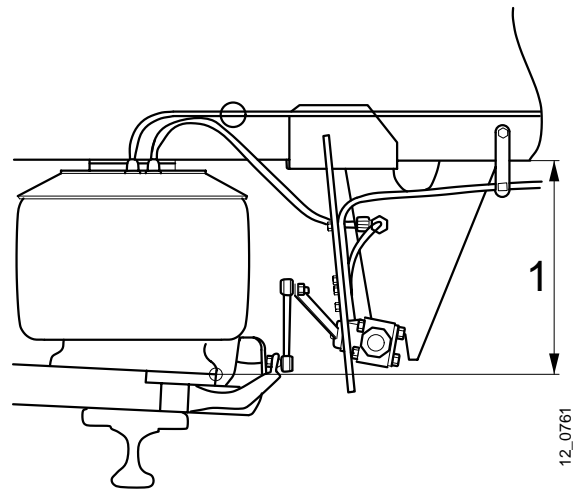

Fig. 1 Measuring calibration levels, front axle (1)

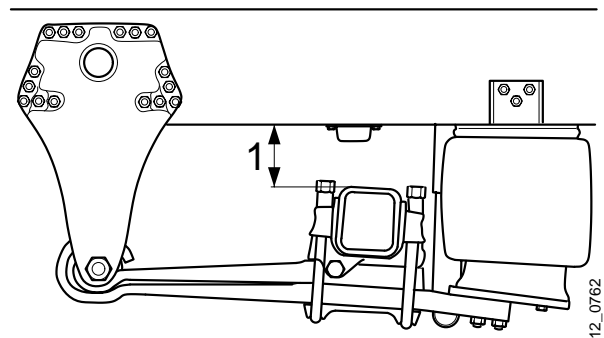

Fig. 2 Measuring calibration levels, driving axle (1). Height is measured against the outside of the frame.

Front

Chassis height	Air spring height	Driving level	Max. level	Lower mechanical stop
Normal	Normal	317 mm	537 mm	(237) mm

Rear

Chassis height	Driving level	Max. level	Lower mechanical stop
Normal	142 mm	262 mm	(42) mm

Calibration

Calibration contact G9 is used during level calibration. This is located under the central electric unit.

During calibration, the tag axle should be lowered.

- 1 Place chocks behind the wheels and release the parking brake.
- 2 Switch off the power using the starter key and leave the starter power on for at least 7 seconds.
- 3 Earth calibration contact G9.
- 4 Switch on starter voltage using the starter key.
- 5 ELC now checks its lamps on the instrument panel. This takes about 2 seconds. Within 5 seconds of the check being completed, earth connection to the calibration contact must be interrupted.
- 6 If the request for calibration is understood by the ELC control unit, the level fault light will come on. This lamp will be on during the whole calibration process. If the light does not come on, repeat points 1-4.
- 7 Drive level is calibrated first. Front and rear chassis drive level are set using the control box.
- 8 Earth calibration contact G9.
- 9 Break the earth connection from calibration contact G9.
- 10 The other level which can be calibrated is the **max. level**. Set max. level front and rear using the control box.
- 11 Earth calibration contact G9.
- 12 Interrupt the earth connection from calibration switch G9.
- 13 Finally, calibrate the **mechanical stop**. Lower the chassis until it is resting on the bump stop. Check that movement is not obstructed by the bellows becoming crumpled.
- 14 Earth calibration switch G9.
- 15 Break the earth connection from the calibration contact (G9).
- 16 If calibration is successful the level fault lamp will go out. The system fault lamp lights as an indication that calibration has been successful. If calibration has failed, the level fault lamp lights. Repeat points 1-14
- 17 If calibration has been successful, switch off starter voltage and switch it on again using the starter key. ELC is now ready to be used again.

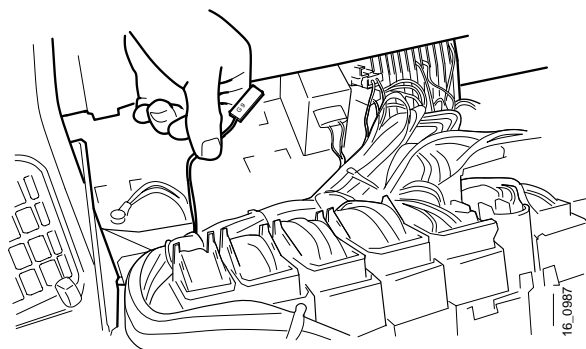

Calibration contact G9



WARNING!

Always use stands when working under vehicles with air suspension.

Compressed air components

Component information

- 1 Valve block
- 2 Air bellows, driving axle
- 3 Air bellows, front axle
- 4 Air bellows, tag axle
- 5 Air bellows, tag axle lift
- 6 Pressure monitor, driving axle load
- 7 Pressure monitor, load transfer
- 8 Manifold fitting, 9.3 bar
- 9 To the protection valve for load sensing brake
- 10 Pressure gauge
- 11 Double check valve
- 12 Pressure limiting valve, 8.0 bar
- 13 Extra compressed air tanks
- 14 Overflow valve, 10.0 bar
- 15 From compressor, 12.2 bar
- 16 Test connection

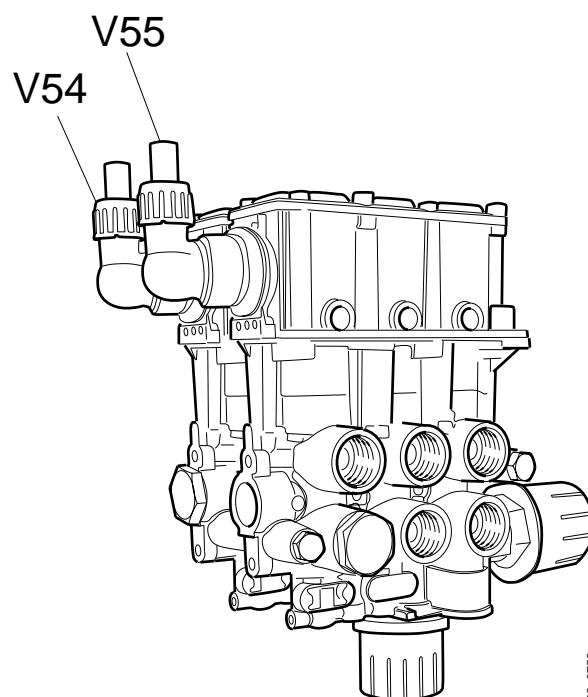

Valve block 6x2

Electrical connections

V54 and V55 each consist of three valve coils.

In the connectors, pin 4 is a common earth for all coils.

Coil resistance is 70-80 ohm.

See wiring diagram, circuit 67-73.

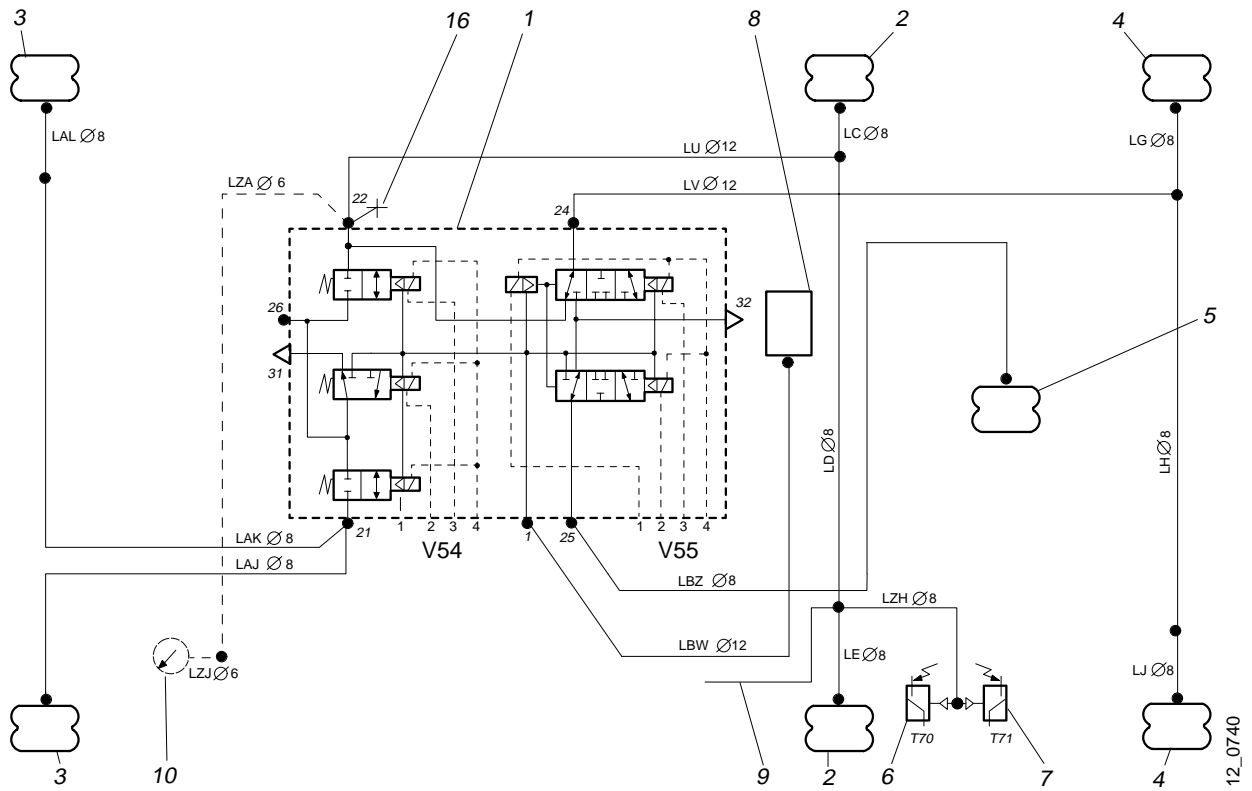

Skeleton diagram for compressed air 6x2

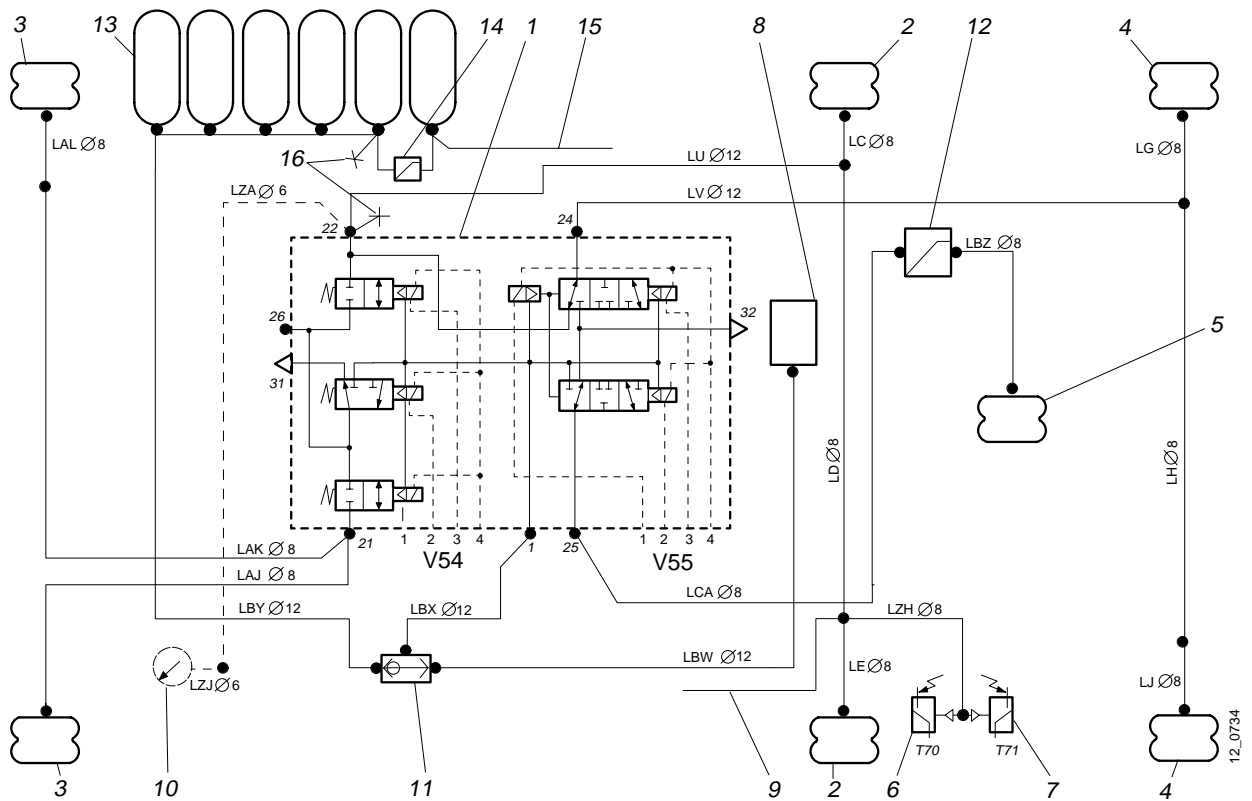

Skeleton diagram for compressed air, 6x2 with extra compressed air tanks

Component information

Component	Description	Circuit
C56	Connector, 18 pin	39
C67	Splice	65
C78	Connector, 9 pin	30
C163	Connector, 9 pin	30
C268	Connector, 12 pin	63
E18	Control unit	1-75
31/ E18	The cable is only connected to earth on vehicles with load transfer without time limitation.	37
G9-4	Cable for level calibration. White cable with green insulation marked G9 under the central electric unit.	38
R8	Relay, brake light	46
S48	Diagnostic switch with diagnostic lamp	15
S105	Switch, tag axle lift and load transfer.	21
S107	Control box	31
T70	Pressure monitor, driving axle load	54
T71	Pressure monitor, load transfer	57
T72	Level sensor, front axle	60
T73	Level sensor, driving axle	63
V54	Magnetic coils, operating front axle and driving axle.	69
V55	Magnetic coils, operating tag axle	72
W51	Level fault lamp	5
W52	System fault lamp	9
W53	Lamp, load transfer	11

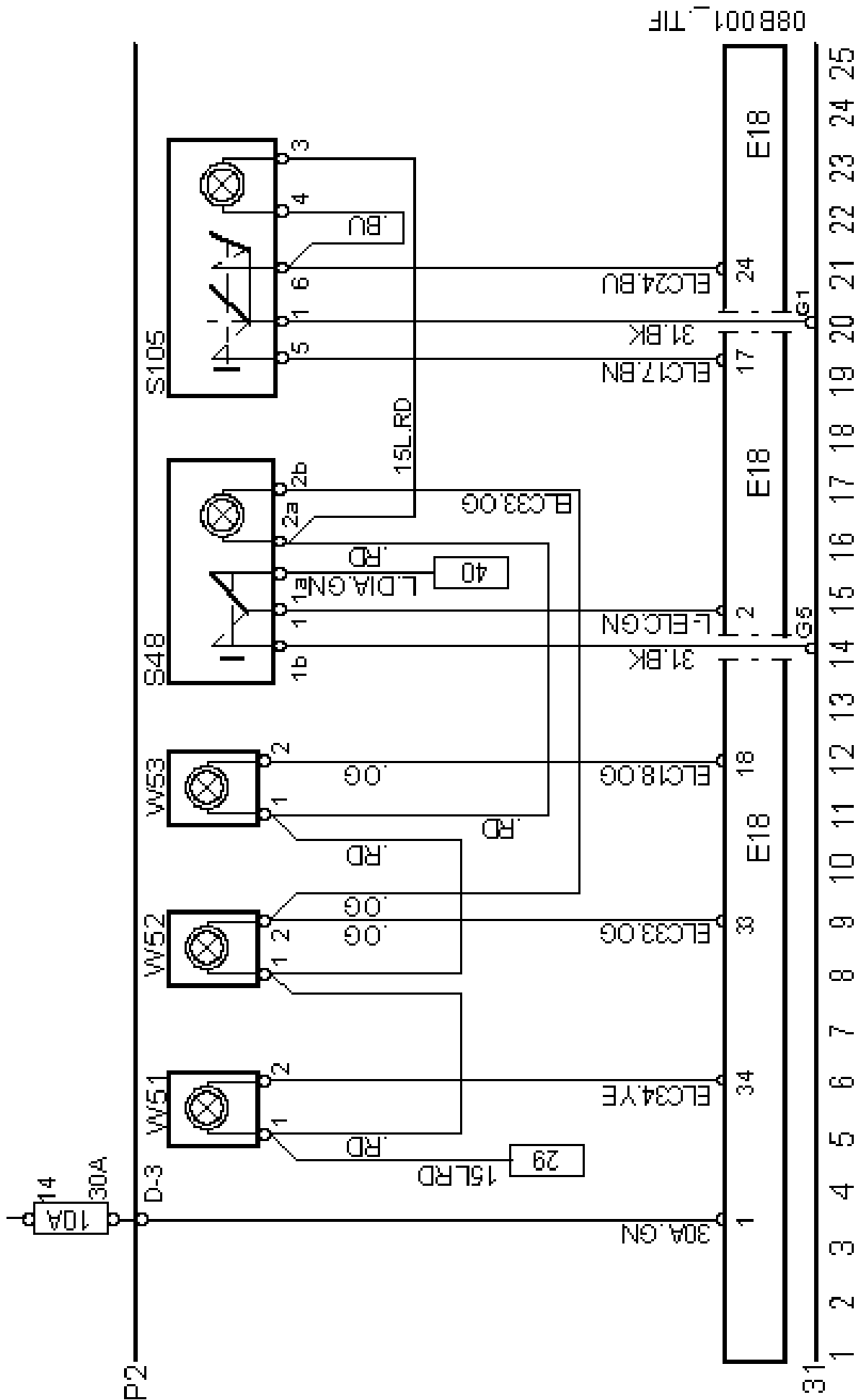

08B001_TIF

08B026.TIF

