

12:03-03

SCANIA

Issue 1 en

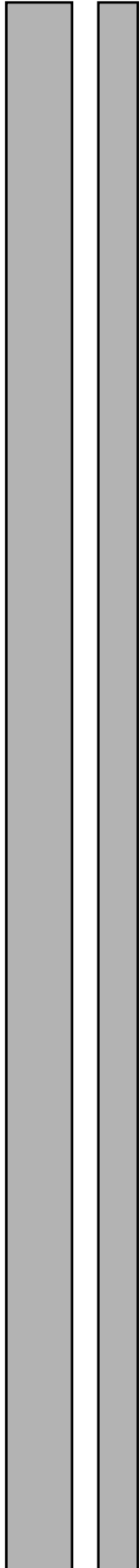

Electronic level control ELC 4x2 A/B

Work description

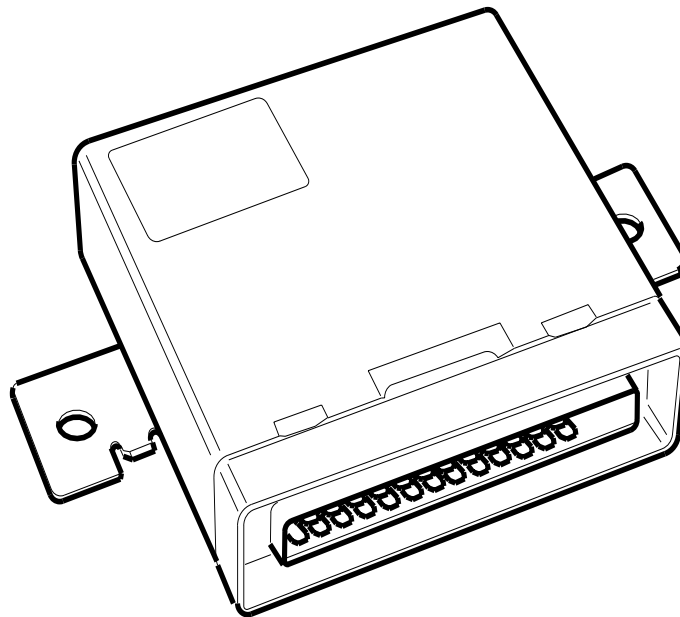

12_0728

cardiagn.com

Contents

Introduction	Important3
	Safety3
Fault diagnosis	Introduction5
	System faults6
Diagnostic feature	Reading flashing codes7
	Erasing fault codes8
Fault codes	Fault code 01-46 9-17
Level sensors	Level sensors18
	Fitting level sensor19
Changing control unit	Configuring21
	Calibration21
Level calibration	Levels22
	Calibration23
Compressed air components	4x2A rear air suspension24
	4x2B full air suspension26
Wiring diagrams	Component information28
	Wiring diagrams 29-31

Introduction

Important

This work description covers the ELC control unit:

Scania part No. **1 374 464**

Safety



Always use stands when working under vehicles with air suspension.

Working under vehicles with air suspension should be carried out in such a way as to avoid the risk of injury. If the frame falls onto the axle it may cause crushing or blow injuries.

The frame falls onto the axle if:

- an air bellows is punctured
- an air line is disconnected
- power is applied to a valve for venting the bellows
- a level sensor is changed when starter voltage is on.

Fault diagnosis

Introduction

ELC continuously checks its own operation. If there is a fault, this is indicated with the system fault lamp. Any faults discovered will be given a fault code and stored in the control unit. Fault codes can then be read as a flashing code on the diagnostic lamp.

Faults which can be revealed by the control unit:

- Short circuit in wiring, sensors and solenoid valves.
- Breaks in wiring, sensors and solenoid valves.
- Incorrect control function (the control unit is unable to raise or lower the chassis to the required level).
- Fault in control unit memory.

When a fault has arisen and been registered, this will be indicated with the system fault lamp. The fault is given fault code which is stored in the control unit.

The system fault lamp also comes on:

- if the ignition is switched on, the lamp flashes to show that it is working. No fault code is generated.
- Level calibration is ended. No fault code is generated.
- if the voltage supply to the control unit is too low between 7.5 and 18 volt. No fault code is generated. If voltage supply is below 7.5 volt, the control unit is switched off entirely.

Faults which cannot be revealed by the control unit:

- Faults in the control box.
- Breaks in wiring for speed signal. The control unit will not change control from fast control to normal control when the vehicle starts moving.
- Break in brake signal cable. The control unit does not stop control during braking.
- Bent lever/link to level sensor. This fault will give incorrect drive level.
- Valve for raising/lowering chassis sticking in open position. The chassis is raised and lowered.
- The control box receives its power supply directly from the same fuse as the control unit. In the case of a short circuit in the control box, the control unit also stops working.

System faults

If the control unit detects a fault, a warning is provided by the system fault lamp.

Faults are divided into two groups, serious and other faults.

Serious faults

In the case of serious faults, the system fault lamp **flashes** and a fault code is generated. Serious faults are divided into two categories.

Serious faults, category 1:

- ROM malfunction. Fault code generated.
- RAM malfunction. Fault code generated.

Level control ceases and drive levels are locked. If any of these faults arises, try switching the power off and then on. If the lamp does not stop flashing, the control unit must be changed.

Serious faults, category 2:

- Faults in wiring to level sensors and solenoid valves (short/break). Fault code generated.
- Faults in level sensors and solenoid valves (short circuit/break). Fault code generated.
- Incorrect parameters. Fault code generated.
- Incorrect calibration values. Fault code generated.

Level control ceases and drive levels are locked. It may be possible to adjust chassis level manually using the control box. Try switching the power off and then on. If the fault is due to defective contacts and corrects itself, the control unit will return to normal level control. The fault code is stored in the control unit.

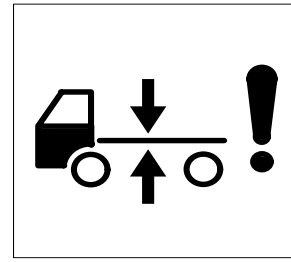

System fault lamp

Other faults

In the case of less serious faults, the system fault lamp lights **continuously**.

The following is considered as a less serious fault:

- Faulty control feature. Control unit is unable to lower/raise the chassis to desired level. Fault code generated.

Diagnostic feature

Reading flashing codes

Fault codes are read using flashing codes on the diagnostic lamp on the instrument panel.

- 1 Press the diagnostic switch beside the diagnostic lamp for at least 2 seconds.
- 2 The switch is released and the first fault code is flashed.
- 3 The flashing code consists of tens and units. Tens are flashed out first. The flashing signal for tens consists of slow flashes 10, 20, 30 etc. Units are flashed out after the tens. The flashing signal for units consists of quick flashes 1, 2, 3, 4 etc.
- 4 The flashing signal is added up to a fault code, which can be read on the fault code list.
- 5 If the diagnostic switch is again depressed the next fault code is flashed out.
- 6 If you wish to read the first flashing code again, switch the power off and then on and start again from the beginning.

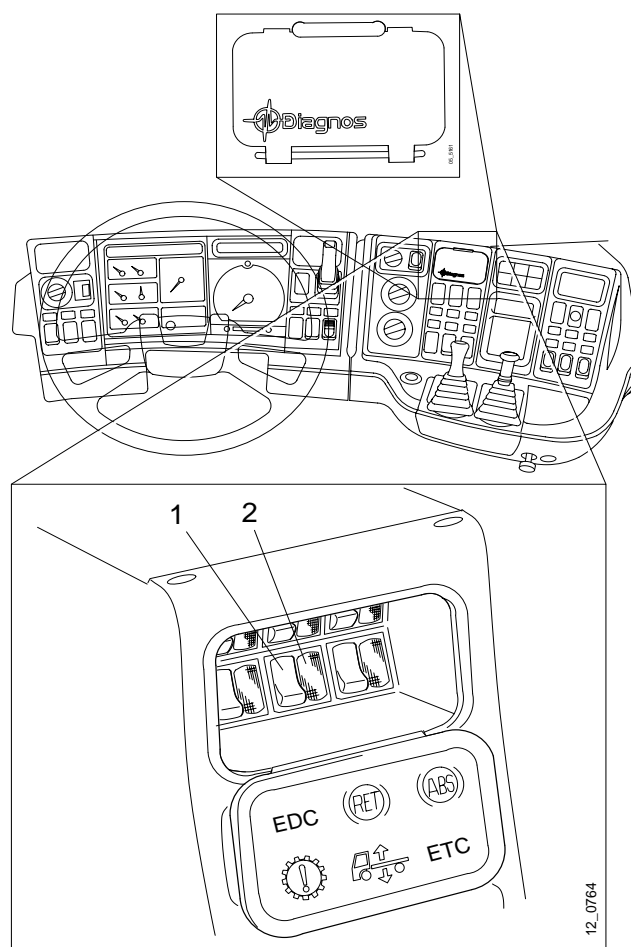

1 Diagnostic switch
2 Diagnostic lamp

No system faults

If there are no faults in the system, no flashing codes can be read.

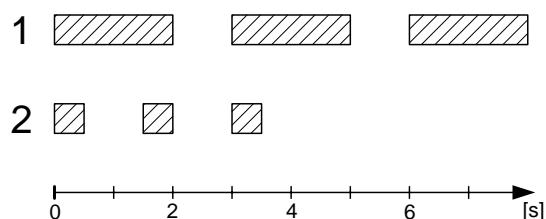

Flashing code for fault code 33.

1 Flashing code, tens
2 Flashing code, units

Erasing fault codes

Fault code are stored in the control unit until they are erased. It is important to erase fault codes when the fault has been rectified so that they do not cause confusion when fault diagnosis is next carried out.

- 1 Switch off the power using the starter key. Press the diagnostic switch and hold it down.
- 2 Turn the starter key to drive and wait for at least three seconds before releasing the diagnostic switch. Erasure is then completed.
- 3 Start the truck and raise and lower it using the control box. Check that no fault codes are regenerated.

Fault codes

Fault code 01

Fault: Parameter fault in control unit.

Cause: The test sum of the parameters is not correct. One of the parameters which controls the work process has assumed an incorrect value.

Comment: When programming the parameter list, the binary parameter codes are added together to a figure which is stored in the control unit. The control unit checks the parameter list against this figure and produces a warning if it is incorrect.

Action: Erase fault code. If the fault code is again generated, reprogram the parameters using Scania Programmer 2. If you do not have Programmer 2 change the control unit.

Fault code 02

Fault: Calibration fault in control unit.

Cause: The test sum during calibration is faulty. One of the levels calibrated in the control unit has assumed an incorrect value.

Comments: During calibration the control unit reads three level signals from the level sensor. The binary codes for these levels are added together to give a figure which is stored in the control unit. The control unit then checks the calibration values against this figure.

Action: Erase fault code. Recalibrate drive level, maximum level and lower mechanical stop if it is regenerated.

Fault code 03

Fault: Fault in control unit integrated memory.

Cause: Test sum in ROM incorrect. Data in ROM has assumed an incorrect value.

Comment: When programming the ROM, the contents are added together to a sum which is stored in the control unit. The control unit then continuously checks the ROM against this sum.

Action: Erase fault code. Change control unit if it is regenerated.

Fault code 04

Fault: Fault in control unit integrated memory.

Cause: Incorrect RAM. Control unit RAM is defective.

Comment: When checking the memory cells in the RAM, the control unit has discovered a defective memory cell.

Action: Erase fault code. Change control unit if it is regenerated.

Fault code 10 or 11

Fault: Break or short circuit in level sensor on driving axle.

Cause: Break or short circuit to +24 volt in sensor T73 or in wiring from pin 19 on the control unit.

Comment: Control unit receives no information about rear chassis height and cannot work.

Action: Measure the resistance across the contact pin on the sensor. Resistance should be 120 ohm. Check the wiring between the control unit and the sensor. See circuit 48 (4x2A) and 69 (4x2B).

Fault code 12

Fault: Break or short circuit in level sensor on front axle. 4x2B only

Cause: Break or short circuit to +24 volt in sensor T72 or in wiring from pin 6 on the control unit.

Comment: Control unit receives no information about front chassis height and cannot work.

Action: Measure the resistance across the contact pin on the sensor. Resistance should be 120 ohm. Check the wiring between the control unit and the sensor. See circuit 66.

Fault code 14 or 15

Fault: Break or short circuit in level sensor on driving axle.

Cause: Break or short circuit to earth in sensor T73 or in wiring from pin 19 on the control unit.

Comment: Control unit receives no information about rear chassis height and cannot work.

Action: Measure the resistance across the contact pin on the sensor. Resistance should be 120 ohm. Check the wiring between the control unit and the sensor. See circuit 48 (4x2A) and 69 (4x2B).

Fault code 16

Fault: Short circuit to earth in level sensor on front axle. 4x2B only.

Cause: Short circuit to earth in sensor T72 or in wiring from pin 6 on the control unit.

Comment: Control unit receives no information about front chassis height and cannot work.

Action: Measure the resistance across the contact pin on the sensor. Resistance should be 120 ohm. Check the wiring between the control unit and the sensor. See circuit 66.

Fault code 20

Fault: Loss of function, raising/lowering spring bellows.

Cause: Break or short circuit to +24 volt in valve coil V51 or wiring from pin 21 on the control unit.

Comment: Control unit is unable to operate the spring bellows on the front axle and driving axle.

Action: Measure resistance across contact pin V51 on the valve block. Resistance should be 100-110 ohm. Check wiring. For 4x2A, see circuit 45. For 4x2B, see circuit 61.

Fault code 21 or 22

Fault: Loss of function, raising/lowering driving axle.

Cause: Break or short circuit to +24 volt in magnetic coil V53 or in wiring from pin 8 on the control unit.

Comment: Control unit is unable to operate the driving axle.

Action: Measure resistance across contact pin V53 on the valve block. Resistance should be 100-110 ohm. Check wiring. For 4x2A, see circuit 41. For 4x2B, see circuit 55.

Fault code 23

Fault: Loss of function, raising/lowering front axle.

Cause: Break or short circuit to +24 volt in magnetic coil V52 or in wiring from pin 10 on the control unit.

Comment: Control unit is unable to operate the front axle.

Action: Measure resistance across contact pin V52 on the valve block. Resistance should be 100-110 ohm. Check wiring. See circuit 58.

Fault code 30

Fault: Loss of function, raising/lowering spring bellows.

Cause: Short circuit to earth in valve coil V51 or wiring from pin 21 on the control unit.

Comment: Control unit is unable to operate the spring bellows on the front axle and driving axle.

Action: Measure resistance across contact pin on valve block. Resistance should be 100-110 ohm. Check wiring. For 4x2A, see circuit 45. For 4x2B, see circuit 61.

Fault code 31 or 32

Fault: Loss of function, raising/lowering driving axle.

Cause: Short circuit to earth in magnetic coil V53 or wiring from pin 8 on the control unit.

Comment: Control unit is unable to operate the driving axle.

Action: Measure resistance across contact pin V53 on the valve block. Resistance should be 100-110 ohm. Check wiring. For 4x2A, see circuit 41. For 4x2B, see circuit 55.

Fault code 33

Fault: Loss of function, raising/lowering front axle.

Cause: Short circuit to earth in magnetic coil V52 or wiring from pin 10 on the control unit.

Comment: Control unit is unable to operate the front axle.

Action: Measure resistance across contact pin V52 on the valve block. Resistance should be 100-110 ohm. Check wiring. See circuit 58

Fault code 40 or 41

Fault: Unsatisfactory control when raising rear of chassis.

Cause: Rear level sensor has, for 30 seconds, given a level signal which is lower than the level to which the control unit is attempting to adjust the vehicle.

Comment: Fault code cannot be generated until at least 15 minutes after the starter power is switched on.

This is to ensure that there is sufficiently high system pressure in the compressed air system.

Action: Check air pressure. Check that air is reaching the bellows, look for leakage, blocked air lines and seizing valves. Check that the sensor link and lever have not been bent or become detached.

Fault code 42

Fault: Unsatisfactory control when raising front of chassis.

Cause: The level sensor has, for 30 seconds, been giving a level signal which is lower than that to which the control unit is attempting to adjust the vehicle.

Comment: Fault code cannot be generated until at least 15 minutes after the starter power is switched on.

This is to ensure that there is sufficiently high system pressure in the compressed air system.

Action: Check air pressure. Check that air is reaching the bellows, look for leakage, blocked air lines and seizing valves. Check that the sensor link and lever have not been bent or become detached.

Fault code 44 or 45

Fault: Unsatisfactory control when lowering rear of chassis.

Cause: The rear level sensor has, for 30 seconds, been providing a level signal which is higher than that level to which the control unit is attempting to adjust the vehicle.

Comment: Fault code cannot be generated until at least 15 minutes after the starter power is switched on.

Action: Look for blocked air lines. Check if the sensor link or lever has become bent or detached. Check if the valve is seizing in raising position. Check that there is nothing mechanical preventing lowering.

Fault code 46

Fault: Unsatisfactory control when raising chassis at front.

Cause: The level sensor has, for 30 seconds, been giving a level signal which is higher than that level to which the control unit is attempting to adjust the vehicle.

Comment: Fault code cannot be generated until at least 15 minutes after the starter power is switched on.

Action: Look for blocked air lines. Check if the sensor link or lever has become bent or detached. Check if the valve is seizing in raising position. Check that there is nothing mechanical preventing lowering.

Level sensors



WARNING!

When changing level sensors the truck starter power should be switched off. If the power is switched on the control unit will start to control level as soon as an operational sensor has been connected. This can cause crushing injury.

Changing

When changing level sensors, the rotating lever bracket should be turned as illustrated in figures 3 and 4 so that the sensor works correctly.

The front axle lever bracket is turned as illustrated in figure 3.

The rear axle lever bracket is turned as illustrated in figure 4.

In addition, level calibration must be done in the control unit. See "Level calibration" on page 23.

Fault diagnosis

Level sensors are of inductive type.

During fault diagnosis it is not possible to measure any change in resistance when the sensor is actuated.

Sensor coil resistance will be constant irrespective of how the rotating bracket on the sensor is turned.

Coil resistance is 120 ohm.

Incorrect coil resistance can be due to sensor damage or moisture in the sensor or sensor switch. This will give incorrect driving level.

If the sensor lever or link has been bent or detached, truck driving level will be incorrect.

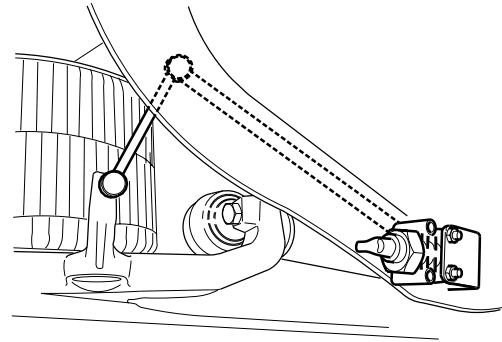

12_0739

Fig. 1 The front level sensor is located on the crossmember under the gearbox.

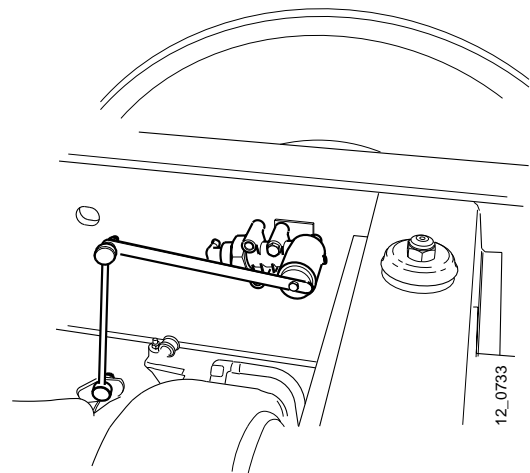

12_0733

Fig. 2 The rear level sensor is located on the right-hand side of the frame above the drive axle.

Fitting level sensor

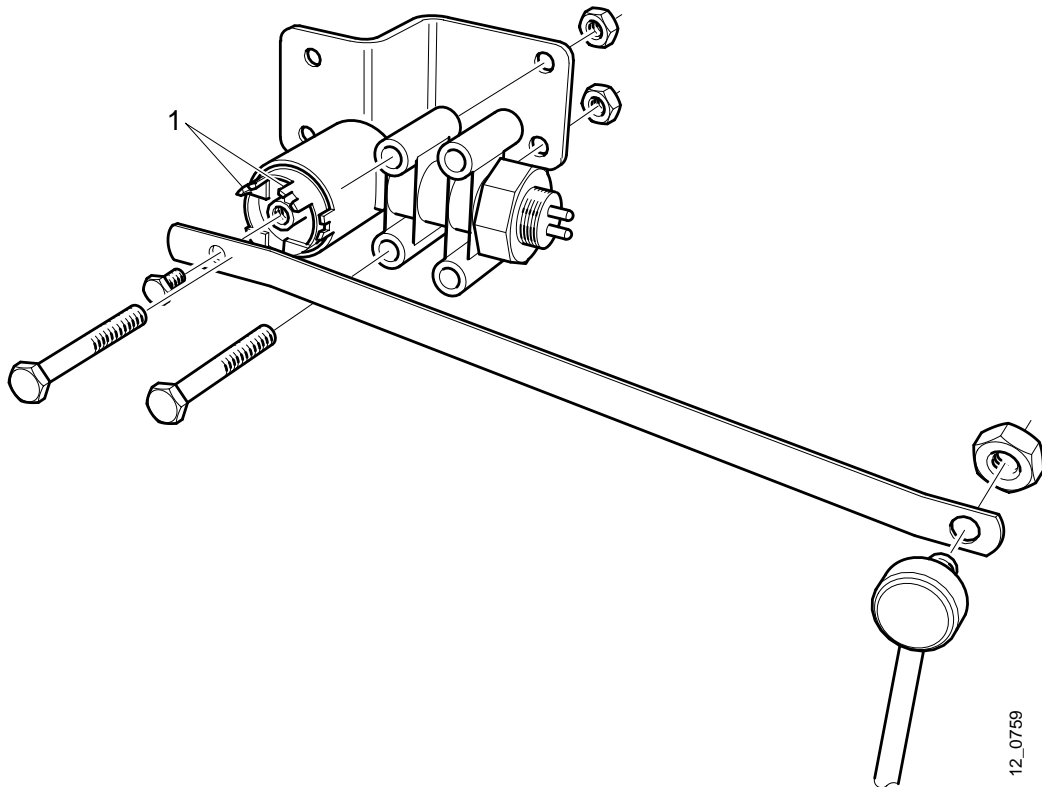

Fig. 3 Fitting front axle level sensor. **N.B.** The raised lugs (1) on the rotating bracket are turned up in order to achieve correct sensor operation.

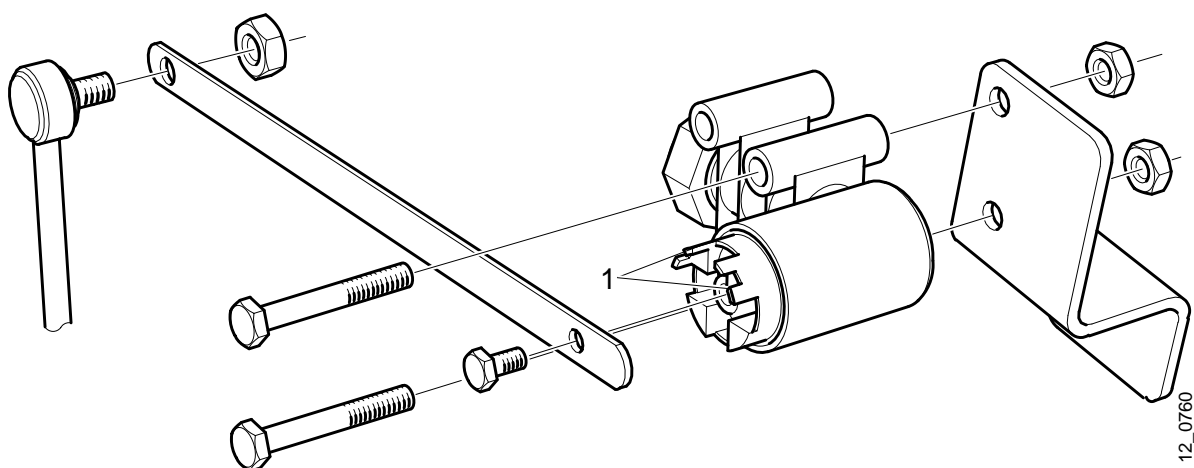

Fig. 4 Fitting drive axle level sensor. **N.B.** The raised lugs (1) on the rotating bracket are turned up in order to achieve correct sensor operation.

Changing control unit

Configuring

When the control unit is changed, the new control unit should be configured for the vehicle. The control unit is supplied from Scania with correct basic configuration.

During calibration, the control unit itself realizes the difference between vehicles with rear air suspension 4x2A and full air suspension 4x2B.

Calibration

When changing control units and level sensors, level sensors should be calibrated for the new control unit. See page 23.

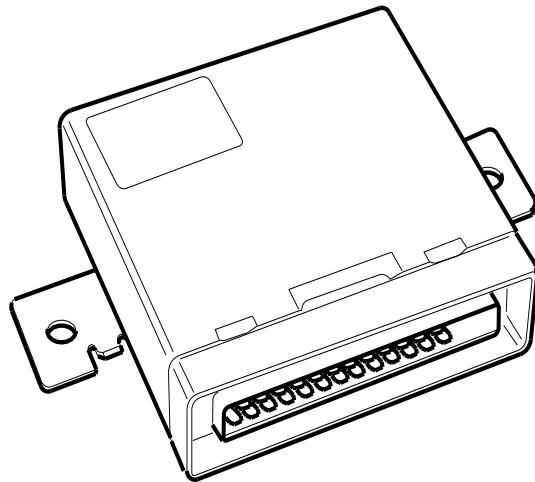

12_0728

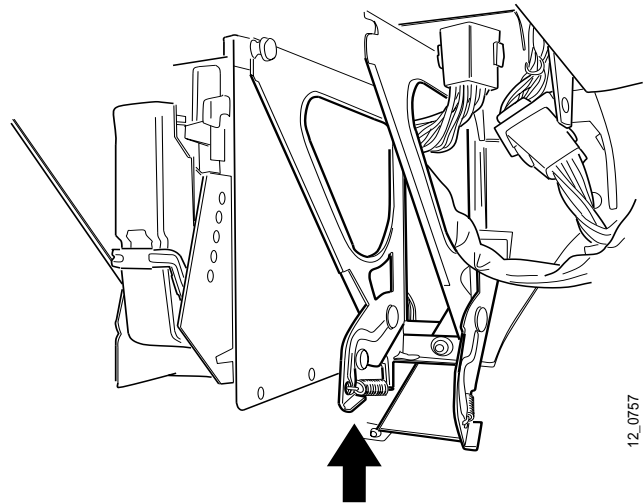

12_0757

The control unit is removed by pushing up the attaching clamp and unplugging it.

Level calibration

Levels

When changing control unit and level sensors, three levels should be calibrated in the control unit.

Driving level- the level at which the vehicle is normally driven.

Max. level- the highest level which can be permitted. If the chassis is raised too far the bellows or shock absorbers may be damaged.

Lower mechanical stop- when the frame bump stop is resting against the axle.

The heights given in the table below are measured as in fig 1 and fig 2.

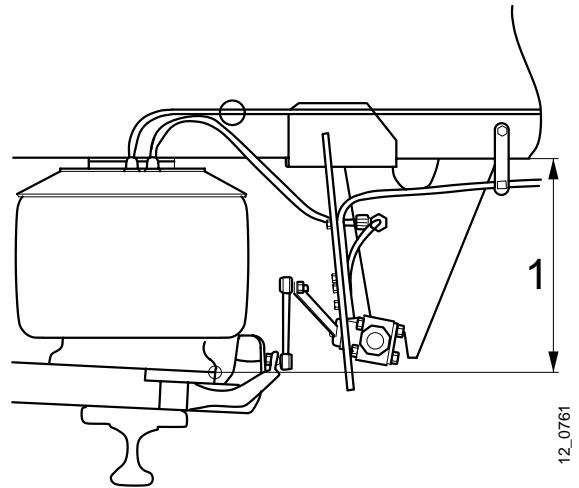

Fig. 1 Measuring calibration levels, front axle (1)

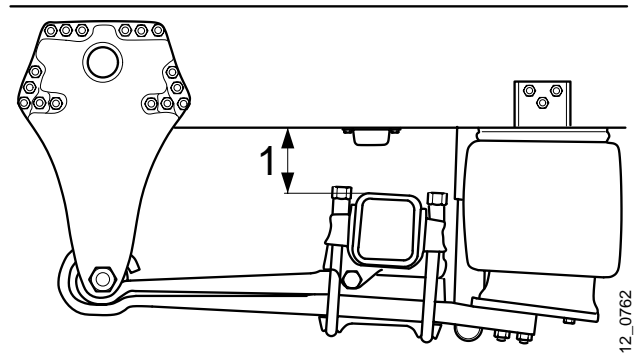

Fig. 2 Measuring calibration levels, driving axle (1). Height is measured against the outer side of the frame.

Front

Chassis height	Air spring height	Driving level	Max. level	Lower mechanical stop
Normal	Normal	317 mm	537 mm	(237) mm
Normal	Low	265 mm	452 mm	(205) mm

Rear

Chassis height	Driving level	Max. level	Lower mechanical stop
Normal	142 mm	262 mm	(42) mm

Calibration

Calibration contact G9 is used for level calibration. This is located under the central electric unit.

- 1 Place chocks behind the wheels and release the parking brake
- 2 Switch off the voltage using the starter key.
- 3 Earth calibration contact G9.
- 4 Switch on starter voltage using the starter key.
- 5 ELC now checks its lamps on the instrument panel. This takes about 2 seconds. Within 5 seconds of the check being completed, earth connection to the calibration contact must be interrupted.
- 6 If the calibration request has been understood by ELC, the control unit level fault lamp will light. The lamp will be on during the entire calibration process. If the lamp does not come on, repeat points 1-4.
- 7 **Drive level** is calibrated first. Chassis drive level at front and rear is set using the control box.



WARNING!

Always use stands when working under vehicles with air suspension.

- 8 Earth calibration contact G9.
- 9 Break the earth connection from calibration contact G9.
- 10 The other level which can be calibrated is max. level. Set **max. level** front and rear using the control box.
- 11 Earth calibration contact G9.
- 12 Interrupt the earth connection from calibration switch G9.

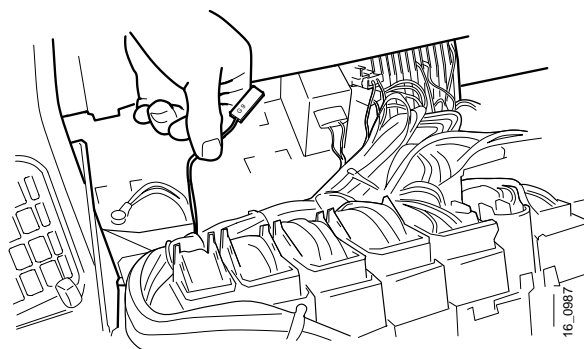

Calibration contact G9

- 13 Finally, calibrate the **lower mechanical stop**. Lower the chassis until it is resting on the bump stop. Check that movement is not limited by the bellows becoming crumpled.
- 14 Earth calibration switch G9.
- 15 Interrupt the earth connection from calibration switch G9.
- 16 If calibration has been successful the level fault lamp will go out. The system fault lamp lights to confirm that calibration has been successful. If calibration has failed the level fault lamp lights. Repeat points 1-14
- 17 If calibration has been successful, switch off starter voltage and switch it on again using the starter key. ELC is now ready to be used again.

Compressed air components

4x2A rear air suspension

- 1 Valve block
- 2 Air bellows, driving axle
- 3 Pressure gauge
- 4 To the protection valve for load sensing brake
- 5 Manifold fitting, 9.3 bar
- 6 Test connection

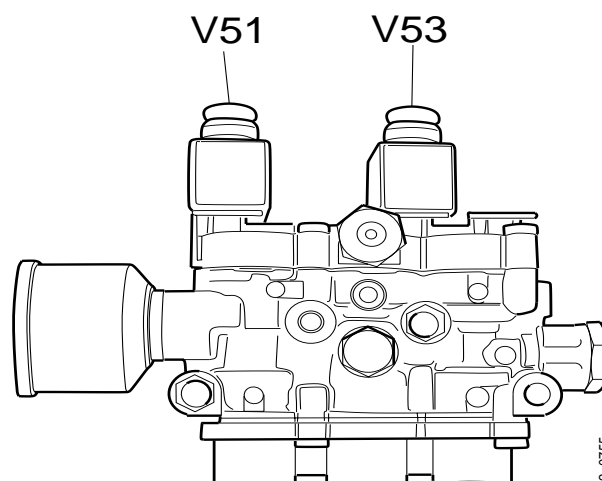

Resistance of valve coils is 100-110 ohm.

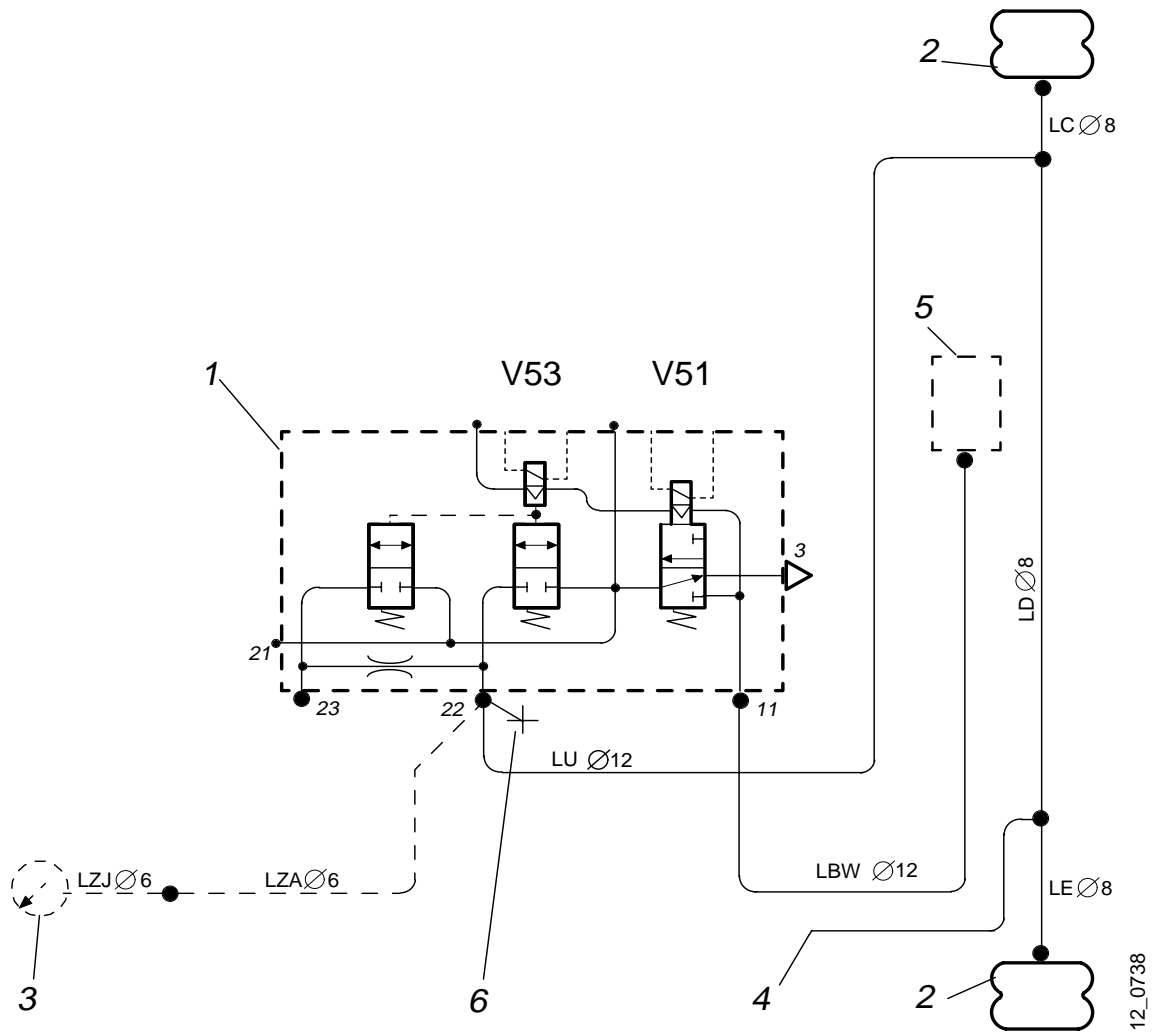

Skeleton diagram for compressed air 4x2A, rear air suspension with ELC

cardiagn.com

12_0738

Compressed air components

4x2B full air suspension

- 1 Valve block
- 2 Air bellows, driving axle
- 3 Air bellows, front axle
- 4 Manifold fitting, 9.3 bar
- 5 To the protection valve for load sensing brake
- 6 Pressure gauge
- 7 Double check valve
- 8 Extra air tanks
- 9 Overflow valve, 10 bar
- 10 From compressor, 12.2 bar
- 11 Test connection

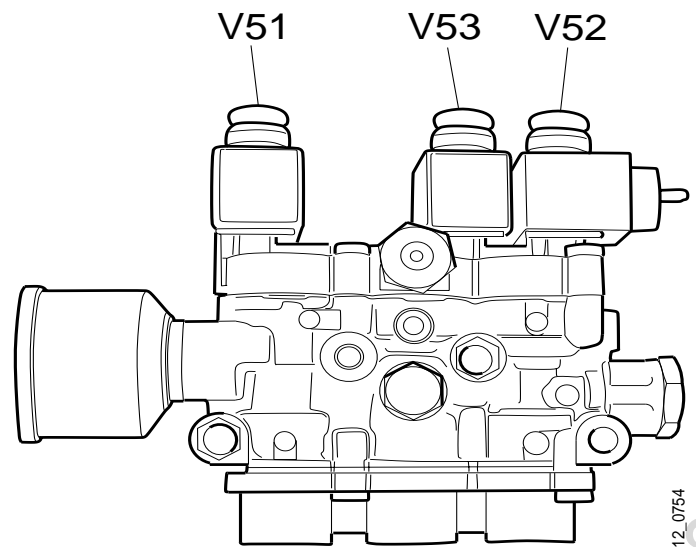

Resistance of valve coils is 100-110 ohm.

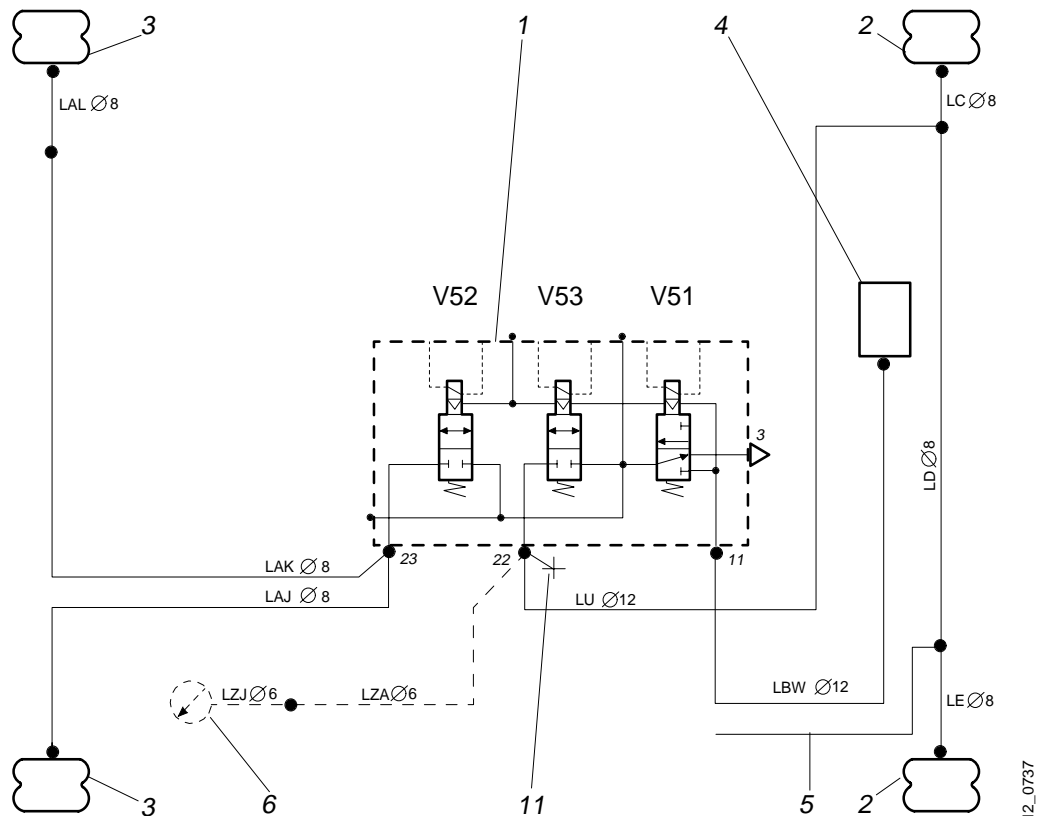

Skeleton diagram for compressed air 4x2B, full air suspension

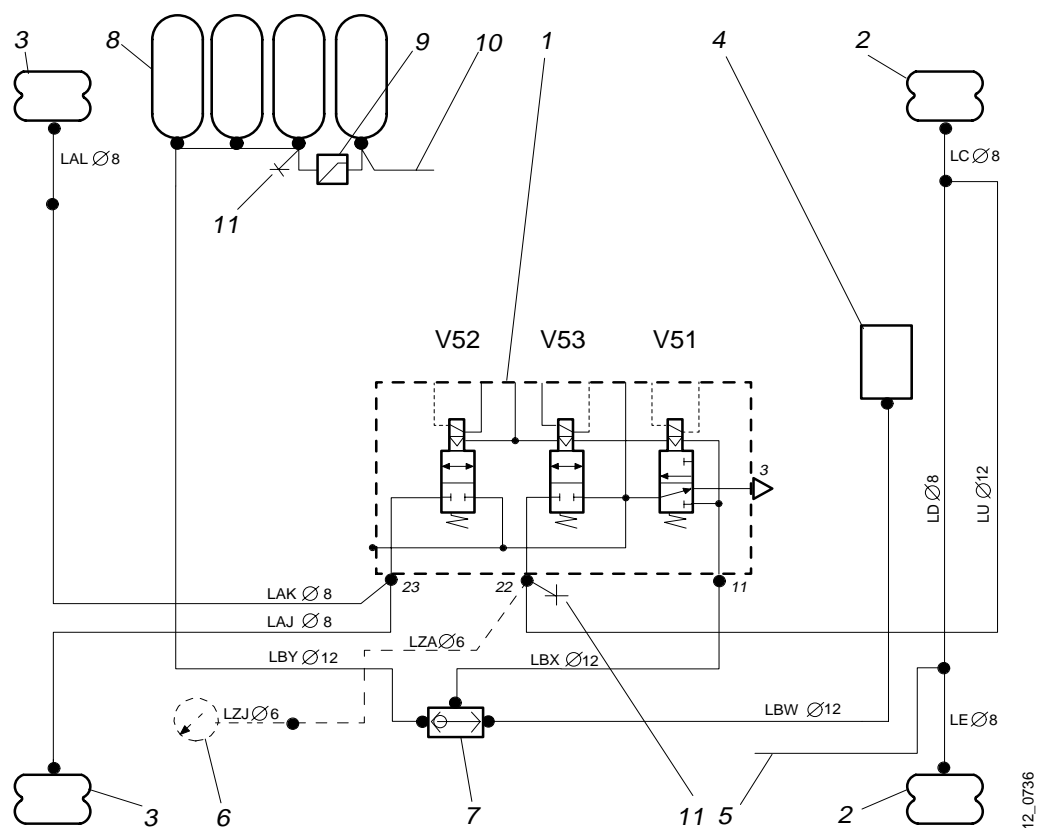

Skeleton diagram for compressed air 4x2B, full air suspension with extra compressed air tanks

cardiagn.com

Component information

Component	Description	Circuit
C56	Connectors	31
C67	Splice 4x2A Splice 4x2B	46 63
C78	Connector, 9 pin	20
C163	Connector, 9 pin	20
C268	Connector, 12 pin	38-72
E18	Control unit	1-75
G9-4	Cable for level calibration. White cable with green insulation marked G9 under the central electric unit.	28
R8	Relay, brake light	38
S48	Diagnostic switch with diagnostic lamp	15
S107	Control box	21
T72	Front axle level sensor, 4x2B only	66
T73	Driving axle level sensor 4x2A Driving axle level sensor 4x2B	49 69
V51	Raising/lowering valve coil, 4x2A Raising/lowering valve coil, 4x2B	45 61
V52	Valve coil, open bellows circuit, front axle. 4x2B only	58
V53	Valve coil, open bellows circuit, driving axle. 4x2A Valve coil, open bellows circuit, driving axle. 4x2B	41 55
W51	Level fault lamp	5
W52	System fault lamp	9

