

SCANIA

12:03-04

Issue 3 en

ELC generation 2

Work description

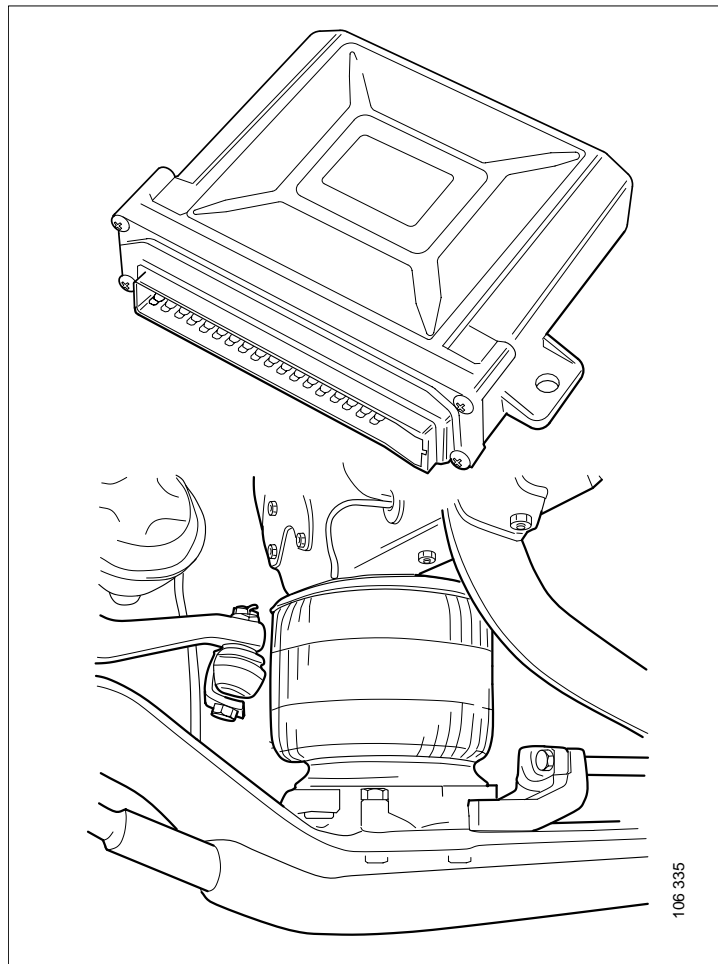

cardiagn.com

Contents

Electrical system	Control unit.....	4
	Extra control box	5
	Temporary drive level switch	6
Valves and sensors	Solenoid valve block	7
	Solenoid valve cassette	8
	Level sensor	9
	Pressure sensor	10
Calibration	Calibration tool	11
	Calibrating the pressure sensor.....	12
	Calibrating the level sensor	14
Compressed air system	Components	16
	Outline diagram for: 4x2A	17
	Outline diagram for: 4x2 b	18
	Outline diagram for: 6x2A, 8x2 A, 6x2*4A and 8x2*6A	19
	Outline diagram for: 6x2B and 6x2*4B	20
	Outline diagram for: 6x4A and 8x4A Without load transfer	21
	Outline diagram for: 6x4A and 8x4A With load transfer	22
	Outline diagram for: 6x4B Without load transfer	23
	Outline diagram for: 6x4B With load transfer.....	24
	Outline diagram for: 6x2/4A	25
	Outline diagram for: 6x2/4B	26
	Outline diagram for: 8x2B and 8x2*6B	27
	Outline diagram for: 8x2/4A	28
	Outline diagram for: 8x2/4B	29
	Outline diagram for: 8x4B Without load transfer	30
	Outline diagram for: 8x4B With load transfer.....	31
	Outline diagram for 8x4*4A Without load transfer	32
	Outline diagram for 8x4*4A With load transfer	33
	Outline diagram for 8x4*4B Without load transfer	34
	Outline diagram for 8x4*4B With load transfer.....	35
Wiring diagram	Component parts.....	36
	Current path diagram.....	38-44

cardiagn.com

Electrical system

Control unit

Renewal



WARNING!

Always use axle stands to support the vehicle when working under vehicles with air suspension.

When a faulty component is renewed, the vehicle may suddenly change drive level.

The control unit is located in the cab, below the central electric unit.

Experience shows that control unit faults seldom occur. Consequently, fault codes and fuses should be checked before the control unit is renewed.

- 1 Switch off the ignition voltage.
- 2 Push up the latch clamp and release the control unit.
- 3 Remove the connection of the control unit.
- 4 Fit the new control unit.

When it is a spare part, the control unit is pre-programmed with standard settings but not calibrated for the level and pressure sensors. To enable the control unit to work correctly, it must be programmed to the correct configuration.

- 5 Program the new control unit using Scania Programmer 2.

- 6 Disconnect the computer and switch off the ignition voltage.
- 7 Calibrate the control unit to the pressure and level sensors. For further information see Calibration.
- 8 Clear any fault codes. For further information, see Troubleshooting - Clearing flashing codes.

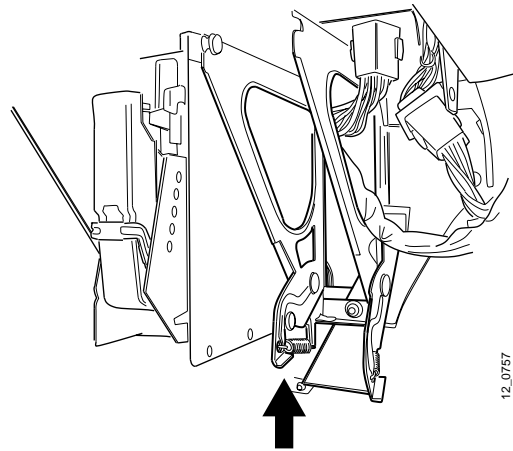

Push up the clamp to release the control unit

Extra control box

Engaging

Load transfer can sometimes be easier with an extra control box at the rear. The vehicle can be fitted with such a control box and it should then also be fitted with a toggle switch in the cab. This is to ensure that both boxes cannot be used at the same time.

Use a cable with four wires, cable area 0.75 mm².

It may be as well to place the rear joint in the junction box on the last crossmember to protect it against moisture.

Connector C 78 is located in the lead-in union below the central electric unit in position 5. Connector C 163 is located on the left cab wall near the control box.

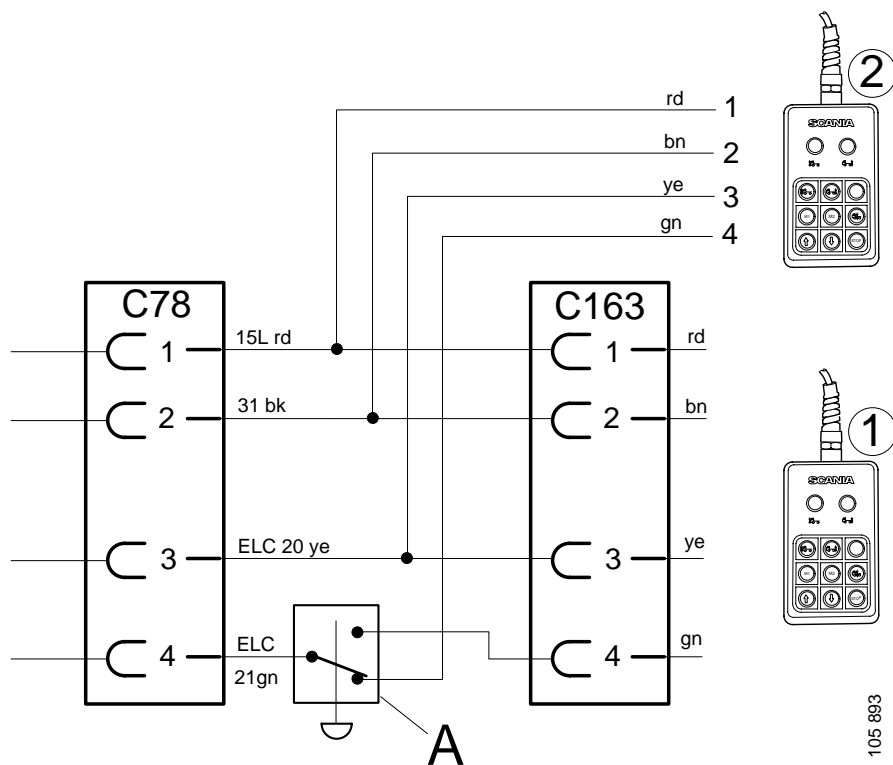

- 1 Control box
2 Extra control box
A Toggle switch

Temporary drive level switch

Engaging

The vehicle can be fitted with a temporary drive level switch.

button is activated. However, the rear drive level will be raised to 65 mm.

The toggle-type switch is connected according to the diagram below. Control unit pin 19 is earthed via the switch pin 2.

Note: After the connection, the temporary drive level must be programmed in the control unit using Scania Programmer 2.

If the programming is not carried out, the front drive level will remain unchanged when the

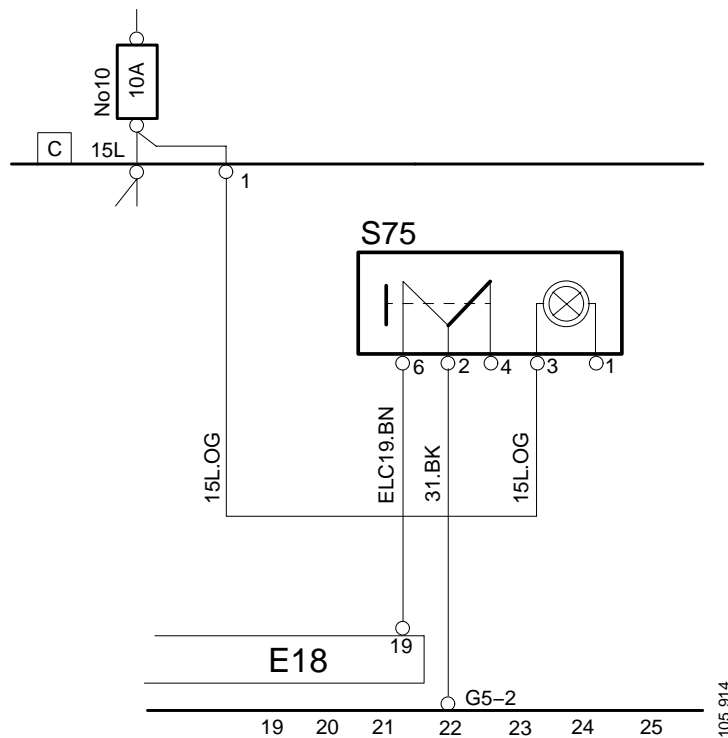

The switch is connected to control unit pin 19.

Valves and sensors

Solenoid valve block



Always use axle stands to support the vehicle when working under vehicles with air suspension.

Empty the compressed air system before detaching the hoses from the solenoid valve blocks.

Always switch off the ignition voltage before any work on the ELC system is undertaken.

Renewal

The generation 2 ELC uses a single or double solenoid valve block for suspension control, V54 or V54+V55. The operation of the valve blocks differs depending on the vehicle configuration.

In production, Scania uses four different solenoid valve blocks. Only two types of block are available as spare parts: One double and one single.

Certain blocks used in production have limited functionality, whereas the spare blocks contain all functions. If a spare block is used for a vehicle with limited functionality, e.g. A-suspension, those outputs that are not used should be sealed off.

When tightening the electrical connection (the DIN connector) it should be tightened until a click is heard.

Solenoid valve cassette

Renewal



WARNING!

Always use axle stands to support the vehicle when working under vehicles with air suspension.

Disconnect all hose connections to the valve block before the cassette is removed. Any remaining pressure in the block can cause parts to be pushed out during dismantling.

Always switch off the ignition voltage before any work on the ELC system is undertaken.

IMPORTANT! It is extremely important for the workplace to be clean when the valve package is dismantled. Even small amounts of dirt can affect functioning.

When renewing the solenoid valve cassette on the valve block, the O-rings should also be renewed.

These bolts are secured in position using locking compound.

When tightening the electrical connection (the DIN connector), it should be tightened until a click is heard.

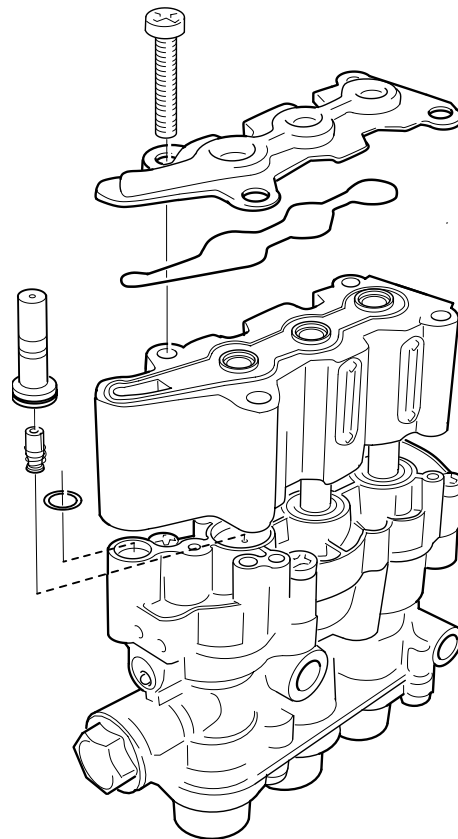

105 917

Solenoid valve cassette components

Level sensor

Specifications

Tightening torque

Level sensor bolts	12 Nm
Arm bolt	3.5 Nm

Renewal

When renewing a level sensor, the rotating bracket for the arm should be turned so that the protruding lugs face upwards.

The front level sensor is located on the crossmember beneath the gearbox.

The rear level sensor is located on the right-hand side of the frame above the rear axle.

When tightening the electrical connection (the DIN connector), it should be tightened until a click is heard.

Note: After renewing the level sensors, a level calibration must be carried out. For further information, refer to section Calibration.



Make sure the ignition voltage is off before commencing renewal of the level sensors.

When a faulty component is renewed, the vehicle may suddenly change drive level if the voltage is on.

Always use axle stands to support the vehicle when working under vehicles with air suspension.

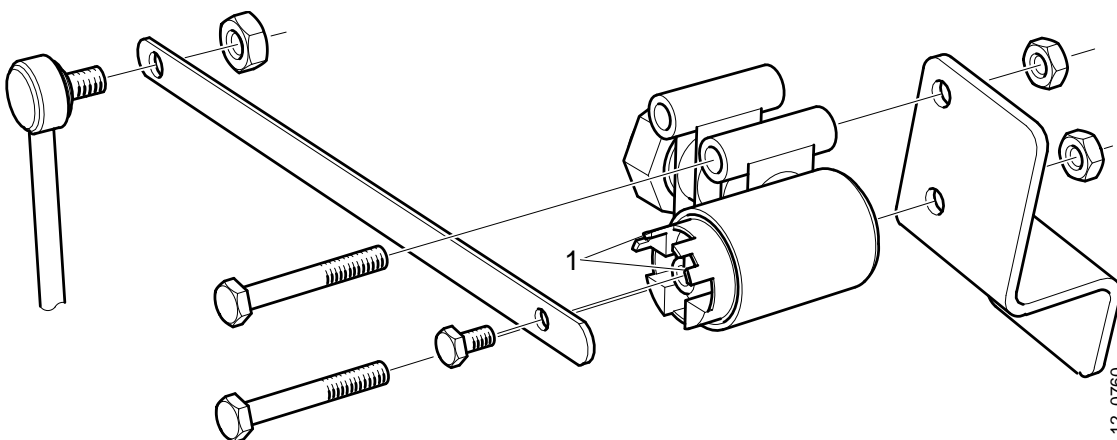

The protruding lugs (1) on the rotating bracket should face upwards before the arm is fitted.

Pressure sensor

Specifications

Tightening torque

Pressure sensor 27 +/- 2 Nm

Renewal



Always use axle stands to support the vehicle when working under vehicles with air suspension.

Make sure the ignition voltage is off before commencing renewal of the level sensors.

Empty the air system before commencing renewal of the solenoid valve block.

Check that the air hole in the pressure sensor connection is not blocked.

When tightening the electrical connection (the DIN connector), it should be tightened until a click is heard.

Note: After renewing the pressure sensors, a calibration must be carried out. For further information, refer to section Calibration.

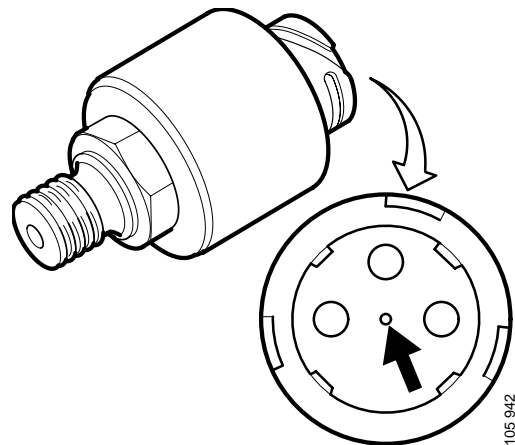

The hole in the pressure sensor connection should not be blocked.

Calibration

As there are individual component differences the control unit must be informed about these. This takes place during calibration.

Calibration should always be carried out when renewing:

- Control unit
- Level sensor
- Pressure sensor

Tip

Calibration tool

A tool can be manufactured to facilitate calibration.

Use a spring-loaded switch, flat pin and flat socket.

Connect the tool between the calibration lead (G9) and the earth ring.

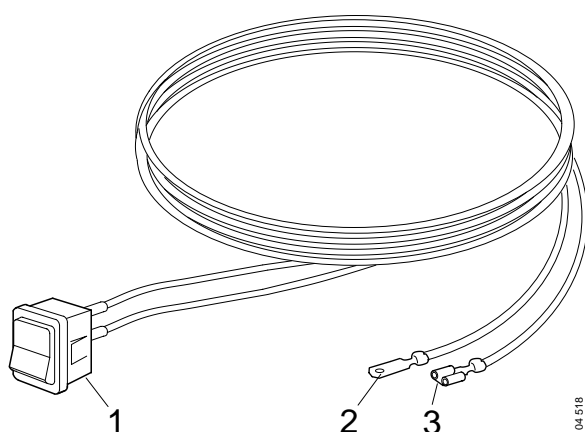

- 1 *Spring-loaded switch*
- 2 *Flat pin*
- 3 *Flat socket*

Pressure sensor

Calibrating the pressure sensor

Note: Applies only to vehicles with load transfer.

For adjustment of air spring heights, refer to Air spring heights under main group 12.

Use calibration lead G9 during calibration (white lead with green insulator marked G9). It is located below the central electric unit and the lead is marked K-dia/C56.

Note: There may be several insulators marked G9 below the central electric unit. These are intended for calibrating other systems.

IMPORTANT! During calibration, the tag axle should be lowered. Ensure that there is working pressure in the system.

- 1 Switch off the ignition power for at least ten seconds.
- 2 Switch on the ignition power.
- 3 Calibration lead G9 must be earthed within two seconds of switching on the ignition power. The warning lamps will come on two seconds after the earthing cable has been connected.
- 4 When the lamps have gone out: Remove the earth connection within five seconds.
- 5 If the control unit detects the request for calibration, the level fault warning lamp will come on.

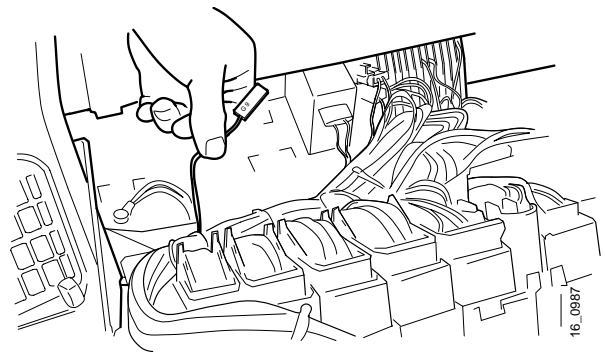

Calibration lead G9

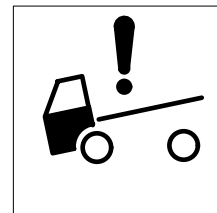

Level fault warning lamp

IMPORTANT! All suspension bellows must be entirely pressure-free.

- 6 Lower the vehicle with the control box to the bump stop.
- 7 Earth calibration lead G9.
- 8 Remove calibration lead G9. The pressure sensors are now registering a pressure value of 0 bar.
- 9 If the calibration has been successful, the system fault warning lamp will come on and the level fault warning lamp will go out.
- 10 Switch off the ignition power and switch it on again. If the calibration has not been successful, the system fault warning lamp will now flash and the level fault warning lamp will go out. If this is the case, repeat steps 1 to 9.
- 11 After completing the calibration, the tag axle lift/load transfer button must be switched on and off again so that the system will work normally.
- 12 Press the normal drive level button on the control box. Wait until the chassis has stopped. Press the button again to obtain normal drive level.

The level fault warning lamp will come on until the vehicle is at the calibrated drive level.

Note: If the control unit is new and has not previously undergone level calibration, then normal drive level will not be obtained.

The ELC is now ready for use again.

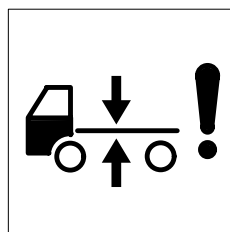

System fault warning lamp

Level sensor

Calibrating the level sensor

For adjustment of air spring heights, refer to Air spring heights.

Use calibration lead G9 during calibration (white lead). It is located below the central electric unit.

IMPORTANT! During calibration, the tag axle should be lowered. Ensure that there is working pressure in the system.

- 1 Place blocks behind and in front of the wheels and release the parking brake.
- 2 Switch off the power with the starter key and leave the ignition power switched off for at least 10 seconds.
- 3 Earth calibration lead G9.
- 4 Switch on the ignition power using the starter key.
- 5 The ELC will now check its lamps on the instrument panel. This takes approximately 2 seconds. The earth connection to the calibration lead must be interrupted within 5 seconds of the lamps going out.
- 6 The level fault warning lamp will remain on during the entire calibration procedure, if the control unit has received a request for calibration.

If the lamp does not come on: repeat steps 2-4.

- 7 First the **drive level** is calibrated. The vehicle drive level is adjusted using the control box. For further information see Air spring heights.
- 8 Earth calibration lead G9.
- 9 Break the earth connection from calibration lead G9.
- 10 The other level which is calibrated is the **maximum level**. Set maximum level, front and rear, with the control box.

Note: The vehicle may stop before reaching maximum level when the control box is first activated. Press the button again to make sure that maximum level is set.

- 11 Earth calibration lead G9.
- 12 Break the earth connection with calibration lead G9.

- 13 Finally, calibrate the **lower mechanical stop**. Lower the vehicle until the frame is resting on the bump stop. Check that the movement is not limited by the bellows crumpling.
- 14 Earth calibration lead G9.
- 15 Break the earth connection from calibration lead G9.
- 16 If the calibration has been successful, the level fault warning lamp will go out. The system fault warning lamp will come on to confirm that the calibration has been successful.
- 17 If the calibration has not been successful, the system fault warning lamp will flash. Repeat steps 1-14.
- 18 If the calibration has been successful: Switch off the ignition power and switch it on again with the starter key.
- 19 After completing the calibration, the tag axle lift/load transfer button must be switched on and off again so that the system will work normally.
- 20 Press the normal drive level button on the control box. Wait until the chassis has stopped. Press the button again to obtain normal drive level.

The level fault warning lamp will come on until the vehicle is at the calibrated drive level.

The ELC is now ready for use again.

Air and electricity

Compressed air system

Components

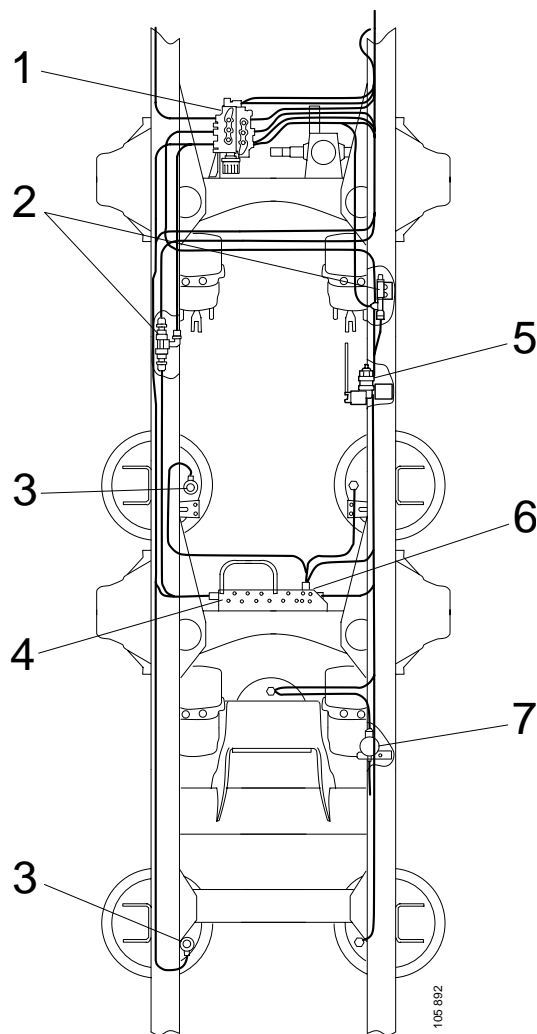

- 1 Solenoid valve block
- 2 Double check valve
- 3 Pressure sensor
- 4 Manifold fitting

- 5 Level sensor, rear
- 6 Manifold fitting
- 7 Pressure limiting valve

Outline diagrams, air

Outline diagram for 4x2A

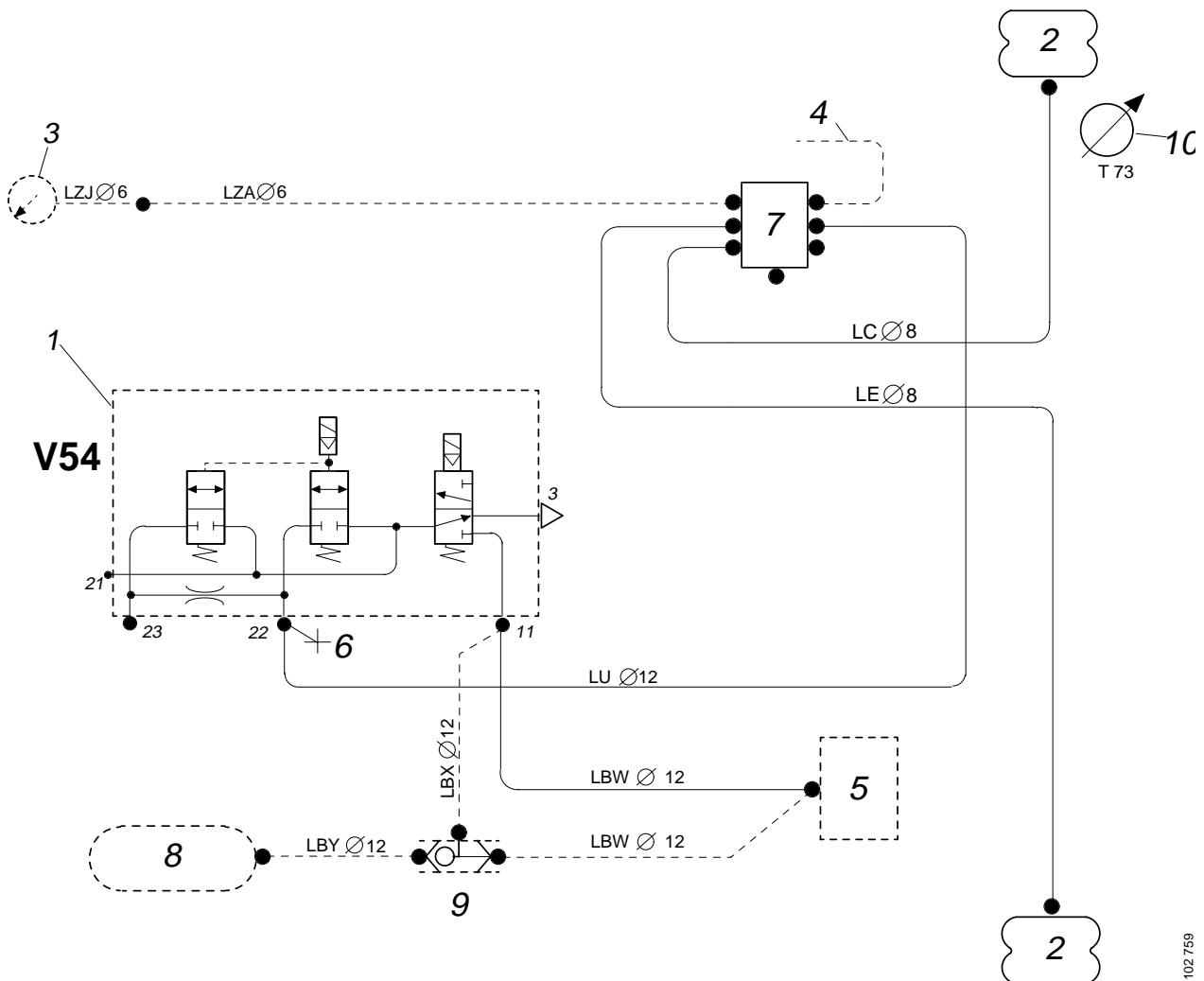

cardiagn.com

102 759

- | | |
|----------------------------|-----------------------|
| 1 Solenoid valve block | 6 Test connection |
| 2 Suspension bellows | 7 Manifold fitting |
| 3 Pressure gauge in cab | 8 Load handling tanks |
| 4 To load-sensing valve | 9 Double check valve |
| 5 Manifold fitting, supply | 10 Level sensor |

Outline diagram for 4x2B

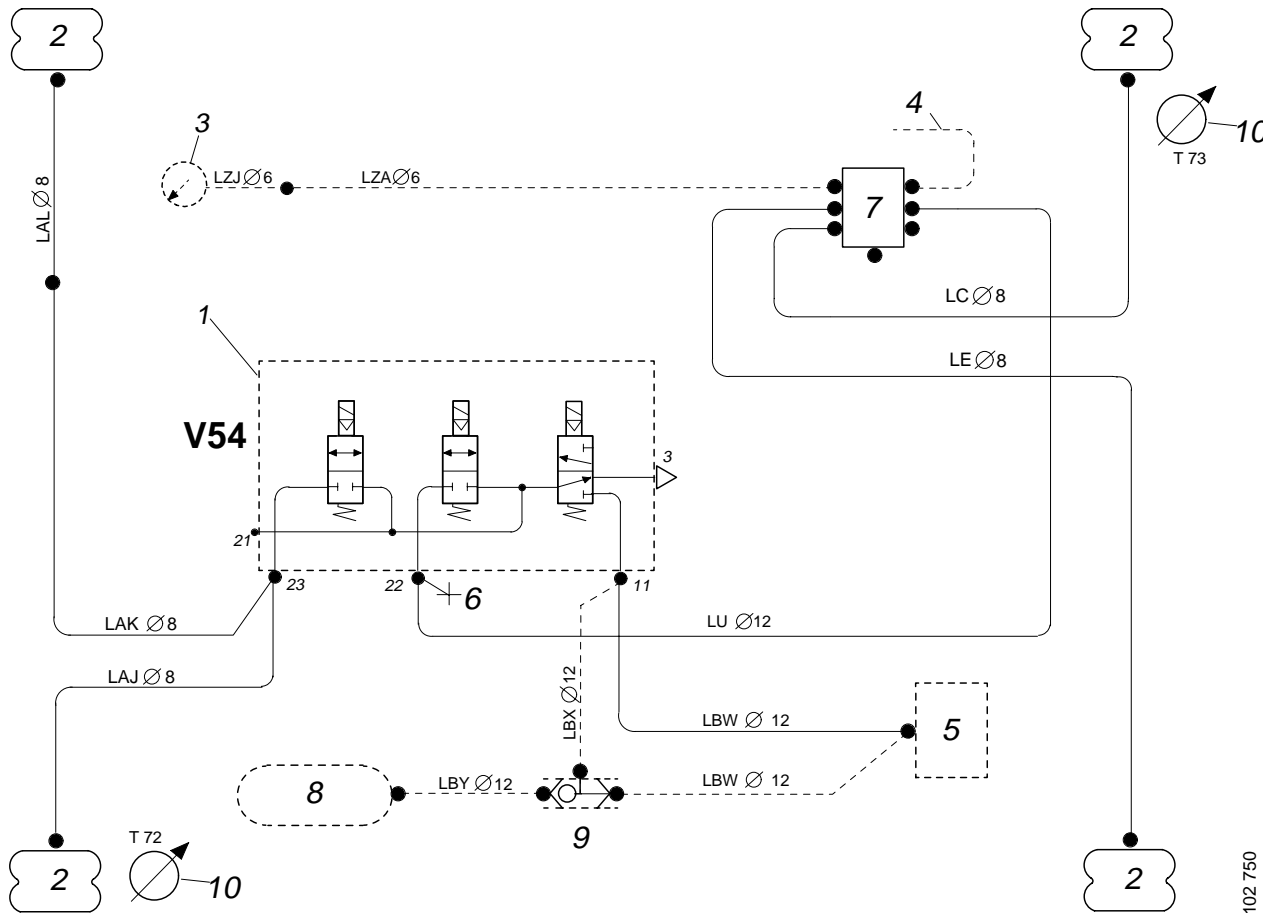

102 750

cardiagn.com

- 1 Solenoid valve block
- 2 Suspension bellows
- 3 Pressure gauge in cab
- 4 To load-sensing valve
- 5 Manifold fitting, supply

- 6 Test connection
- 7 Manifold fitting
- 8 Load handling tanks
- 9 Double check valve
- 10 Level sensor

Outline diagram for 6x2A, 8x2A, 6x2*4A and 8x2*A

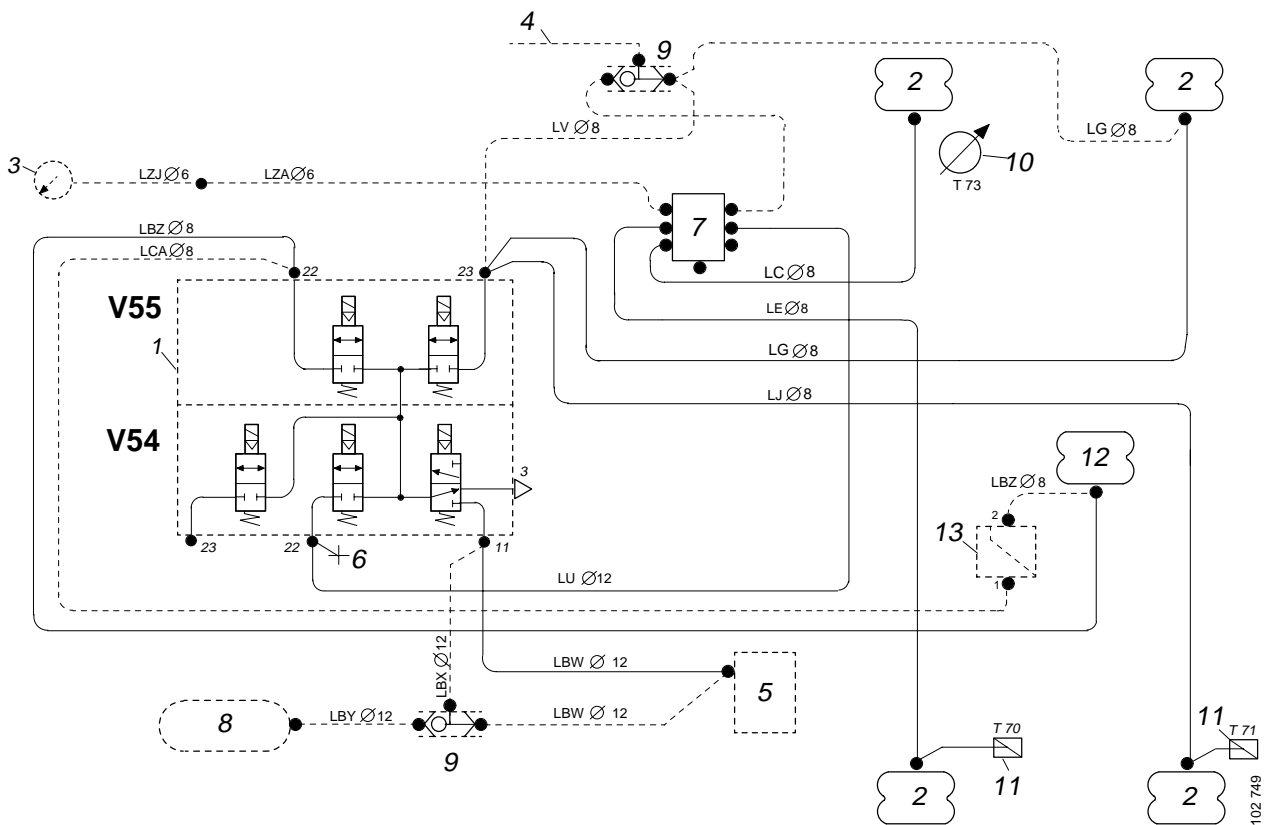

- 1 Solenoid valve block
- 2 Suspension bellows
- 3 Pressure gauge in cab
- 4 To load-sensing valve
- 5 Manifold fitting, supply
- 6 Test connection
- 7 Manifold fitting

- 8 Load handling tanks
- 9 Double check valve
- 10 Level sensor
- 11 Pressure sensor
- 12 Tag axle lift bellows
- 13 Pressure limiting valve 8.0 bar

Outline diagram for 6x2B and 6x2*4B

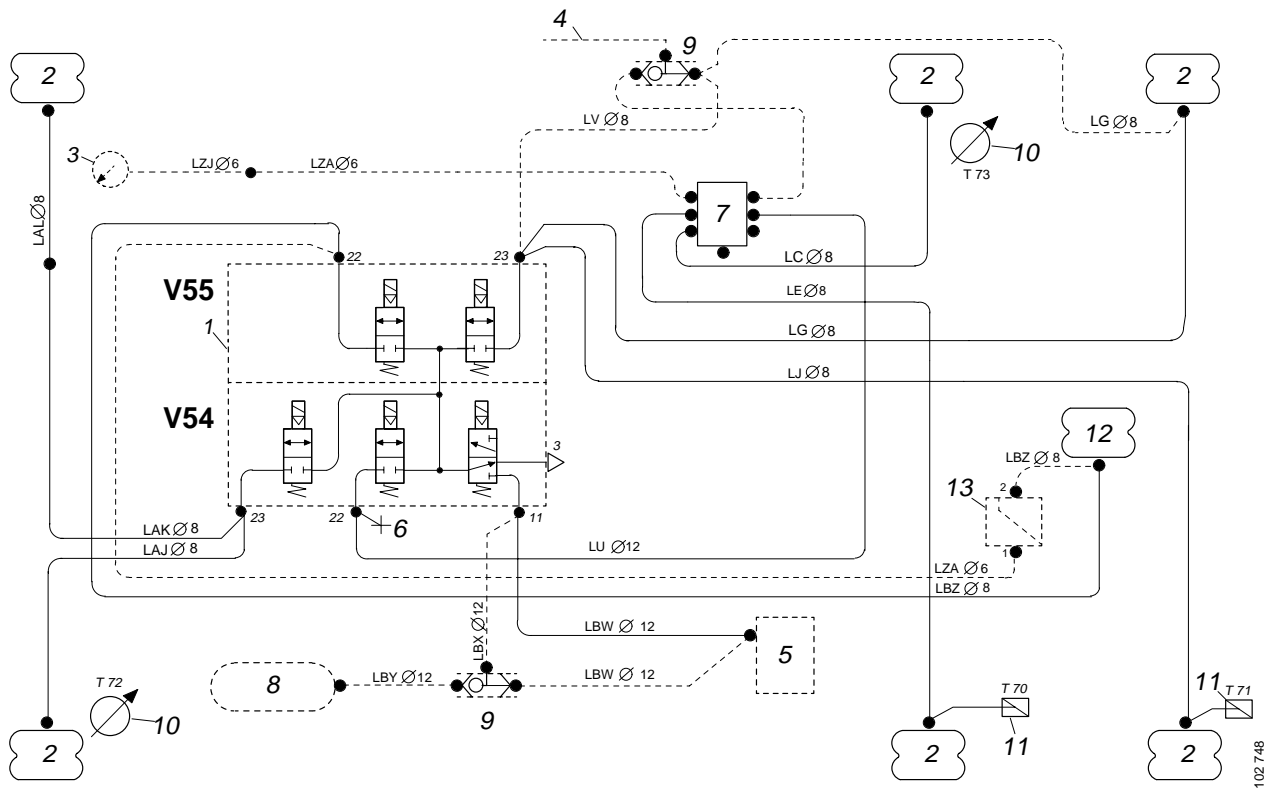

- | | |
|----------------------------|------------------------------------|
| 1 Solenoid valve block | 8 Load handling tanks |
| 2 Suspension bellows | 9 Double check valve |
| 3 Pressure gauge in cab | 10 Level sensor |
| 4 To load-sensing valve | 11 Pressure sensor |
| 5 Manifold fitting, supply | 12 Tag axle lift bellows |
| 6 Test connection | 13 Pressure limiting valve 8.0 bar |
| 7 Manifold fitting | |

cardiagn.com

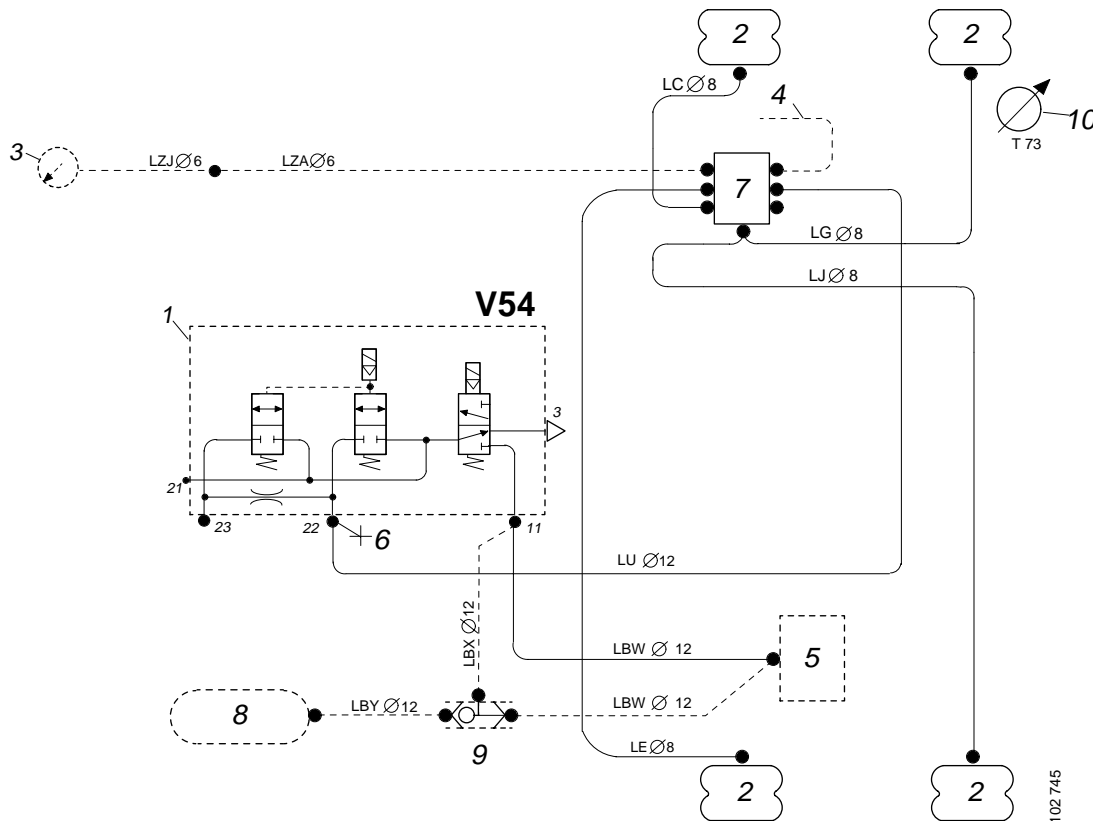
Outline diagram for 6x4A and 8x4A **Without** load transfer

- 1 Solenoid valve block
- 2 Suspension bellows
- 3 Pressure gauge in cab
- 4 To load-sensing valve
- 5 Manifold fitting, supply

- 6 Test connection
- 7 Manifold fitting
- 8 Load handling tanks
- 9 Double check valve
- 10 Level sensor

102 745

Outline diagram for 6x4A and 8x4A **With** load transfer

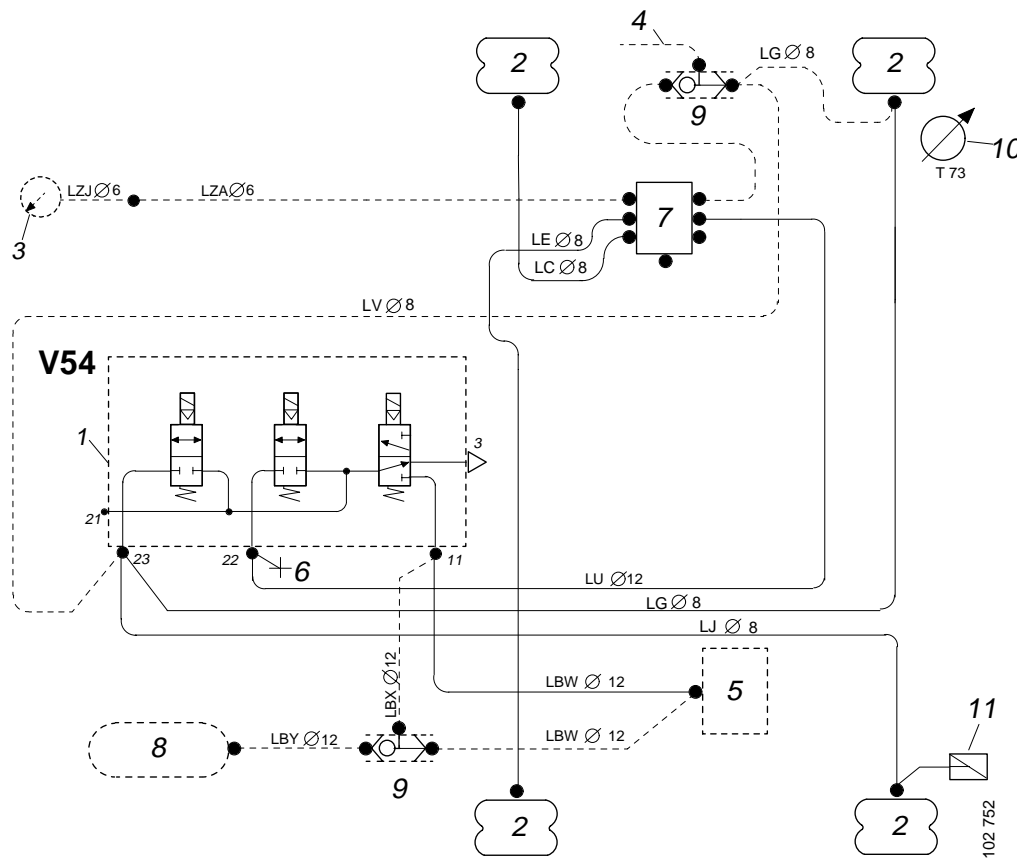

- | | |
|----------------------------|-----------------------|
| 1 Solenoid valve block | 7 Manifold fitting |
| 2 Suspension bellows | 8 Load handling tanks |
| 3 Pressure gauge in cab | 9 Double check valve |
| 4 To load-sensing valve | 10 Level sensor |
| 5 Manifold fitting, supply | 11 Pressure sensor |
| 6 Test connection | |

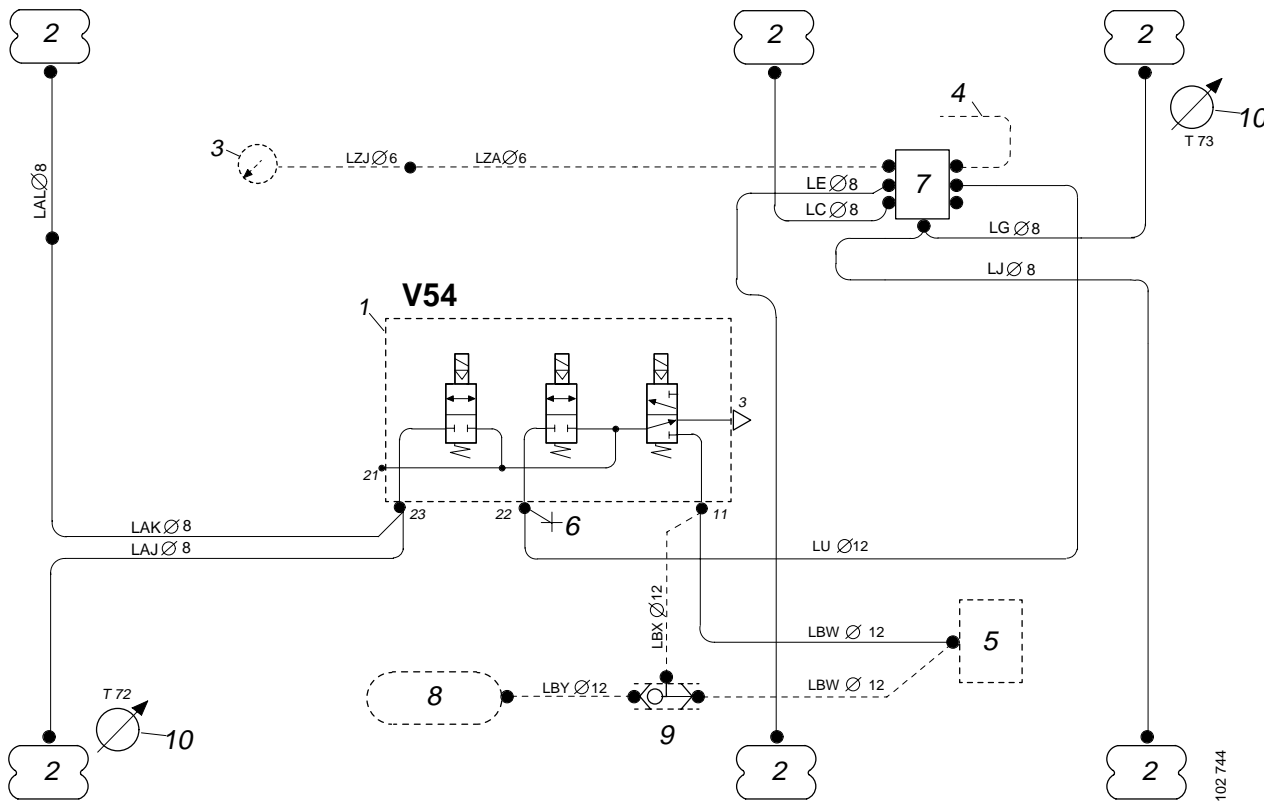
Outline diagram for 6x4B **Without** load transfer

- 1 Solenoid valve block
- 2 Suspension bellows
- 3 Pressure gauge in cab
- 4 To load-sensing valve
- 5 Manifold fitting, supply

- 6 Test connection
- 7 Manifold fitting
- 8 Load handling tanks
- 9 Double check valve
- 10 Level sensor

Outline diagram for 6x2/4A

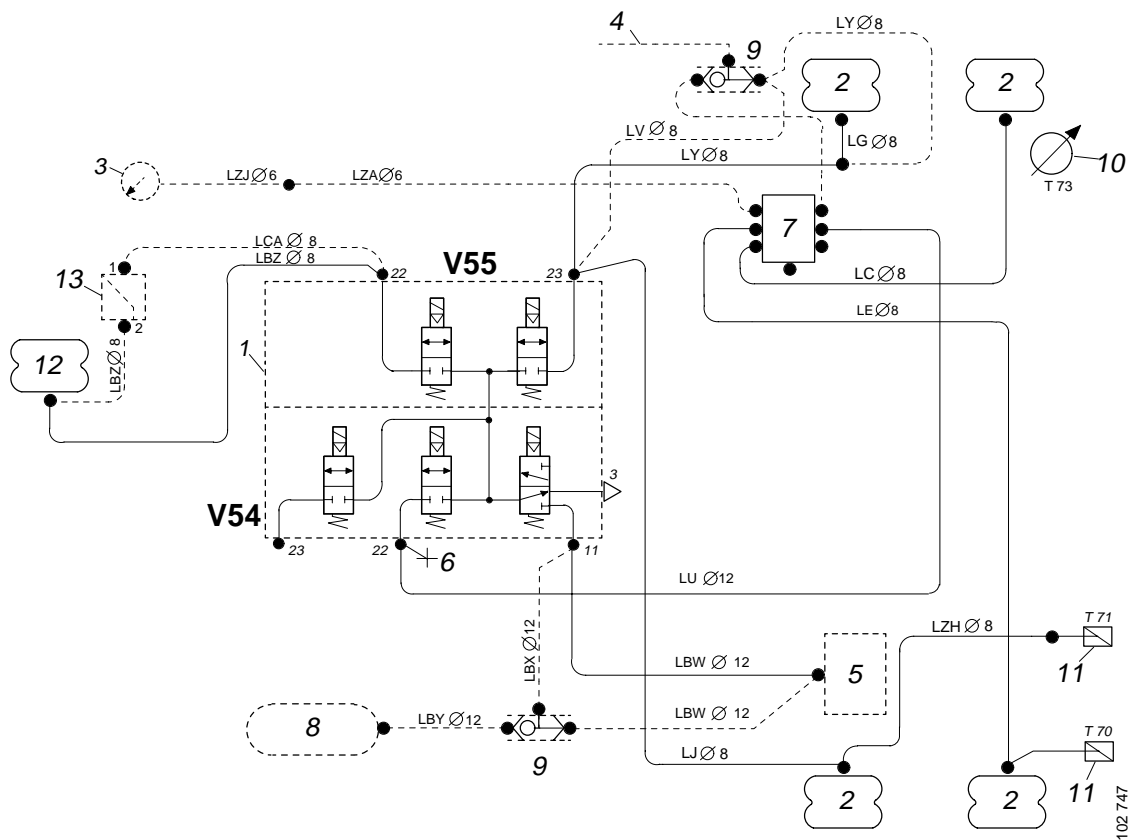

- | | |
|----------------------------|------------------------------------|
| 1 Solenoid valve block | 8 Load handling tanks |
| 2 Suspension bellows | 9 Double check valve |
| 3 Pressure gauge in cab | 10 Level sensor |
| 4 To load-sensing valve | 11 Pressure sensor |
| 5 Manifold fitting, supply | 12 Tag axle lift bellows |
| 6 Test connection | 13 Pressure limiting valve 8.0 bar |
| 7 Manifold fitting | |

Outline diagram for 6x2/4B

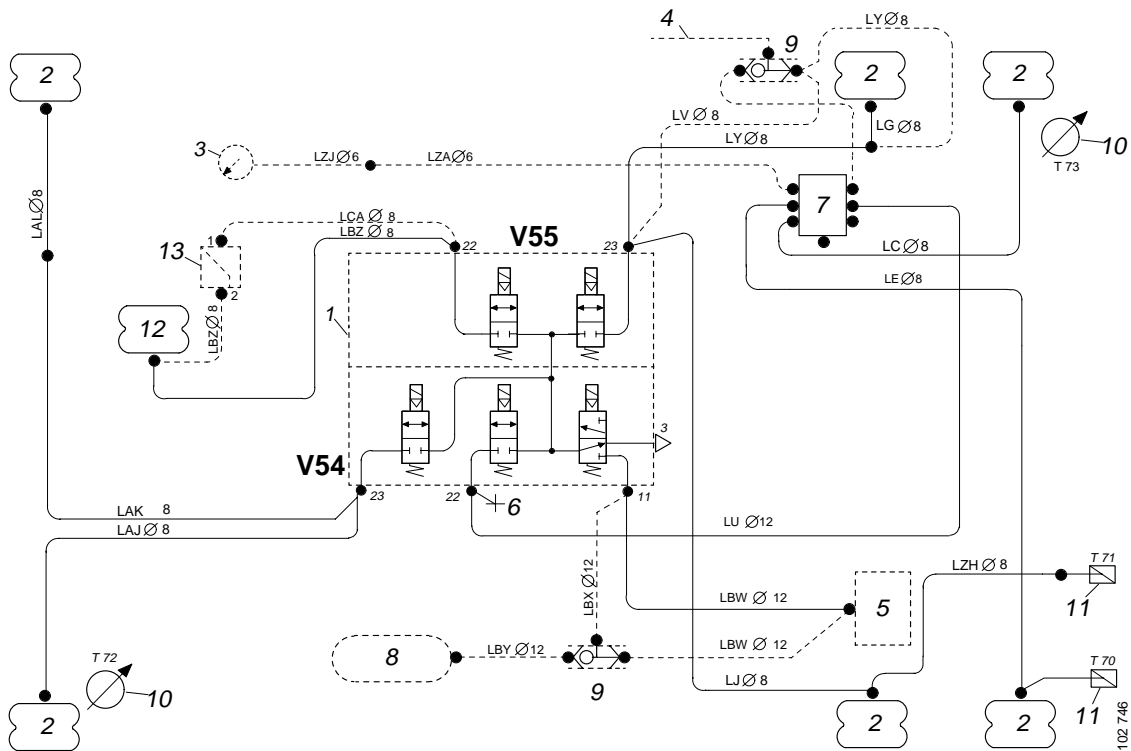

- | | |
|----------------------------|------------------------------------|
| 1 Solenoid valve block | 8 Load handling tanks |
| 2 Suspension bellows | 9 Double check valve |
| 3 Pressure gauge in cab | 10 Level sensor |
| 4 To load-sensing valve | 11 Pressure sensor |
| 5 Manifold fitting, supply | 12 Tag axle lift bellows |
| 6 Test connection | 13 Pressure limiting valve 8.0 bar |
| 7 Manifold fitting | |

cardiagn.com

Outline diagram for 8x2B and 8x2*6B

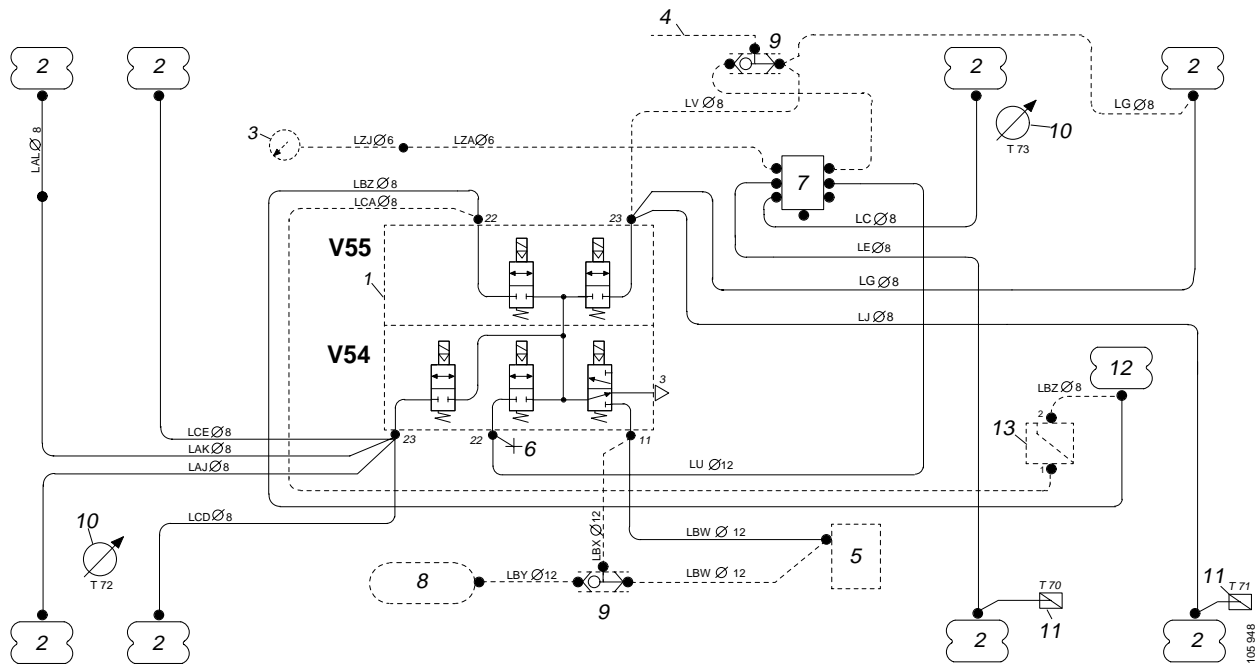

- | | |
|----------------------------|------------------------------------|
| 1 Solenoid valve block | 8 Load handling tanks |
| 2 Suspension bellows | 9 Double check valve |
| 3 Pressure gauge in cab | 10 Level sensor |
| 4 To load-sensing valve | 11 Pressure sensor |
| 5 Manifold fitting, supply | 12 Tag axle lift bellows |
| 6 Test connection | 13 Pressure limiting valve 8.0 bar |
| 7 Manifold fitting | |

Outline diagram for 8x2/4A

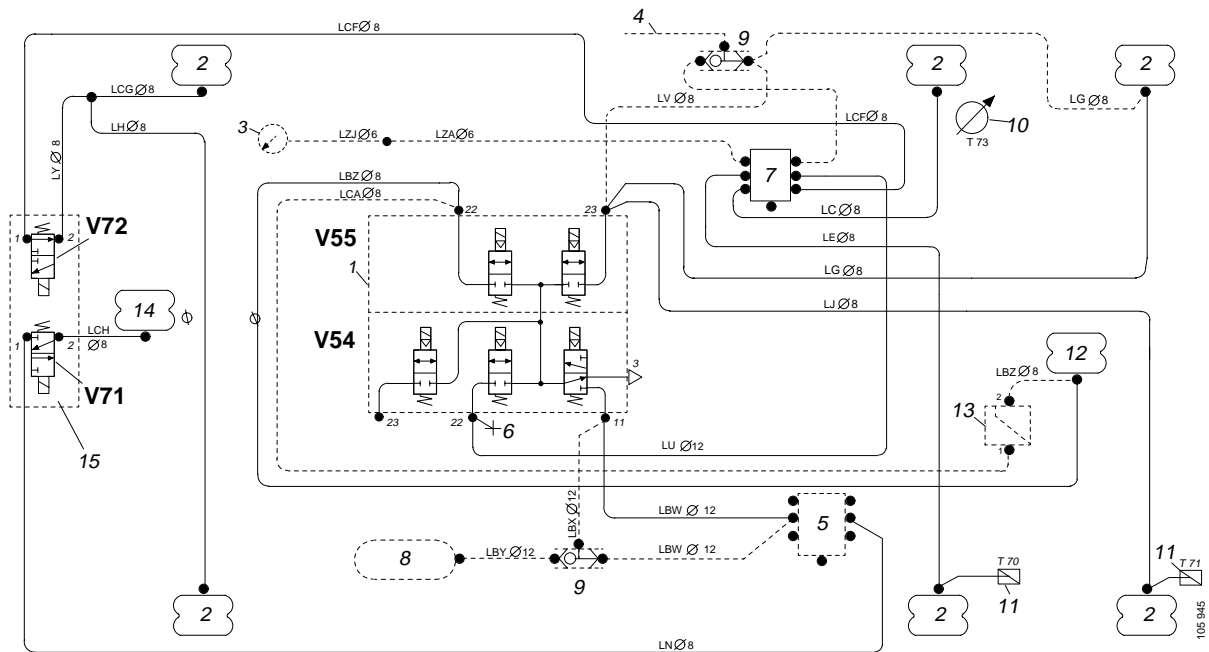

- | | |
|----------------------------|------------------------------------|
| 1 Solenoid valve block | 9 Double check valve |
| 2 Suspension bellows | 10 Level sensor |
| 3 Pressure gauge in cab | 11 Pressure sensor |
| 4 To load-sensing valve | 12 Tag axle lift bellows |
| 5 Manifold fitting, supply | 13 Pressure limiting valve 8.0 bar |
| 6 Test connection | 14 Front tag axle lift bellows |
| 7 Manifold fitting | 15 Front tag axle solenoid valves |
| 8 Load handling tanks | |

cardiagn.com

Outline diagram for 8x2/4B

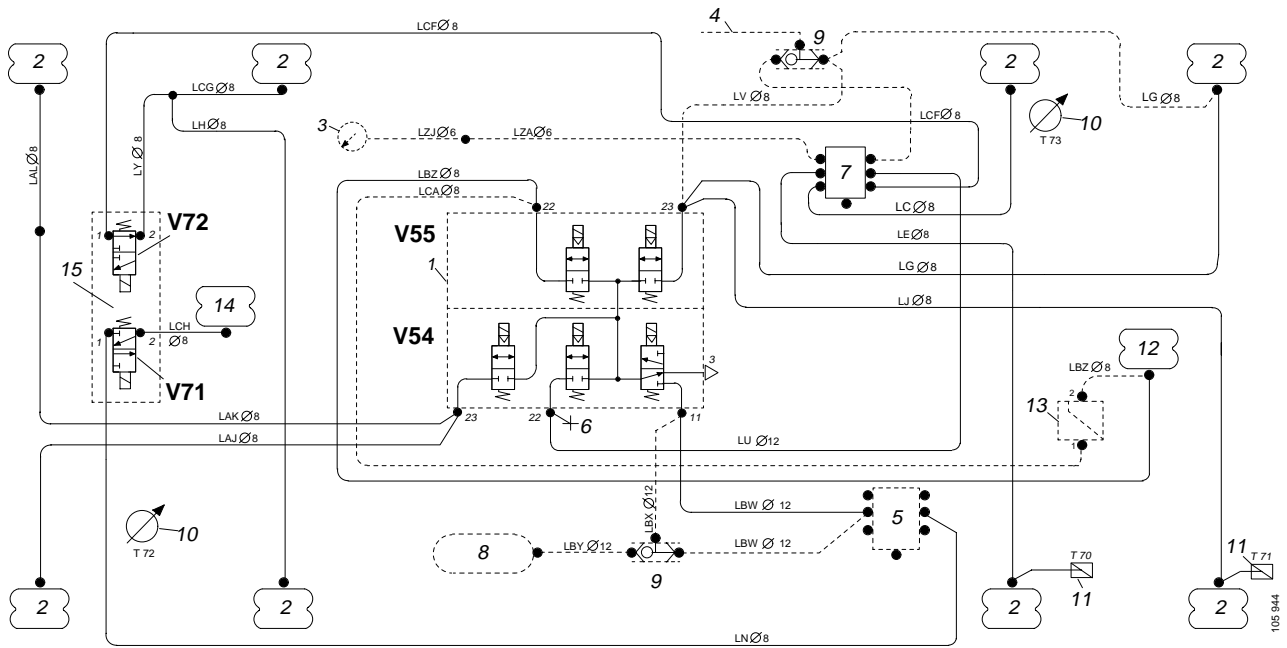

- | | |
|----------------------------|------------------------------------|
| 1 Solenoid valve block | 9 Double check valve |
| 2 Suspension bellows | 10 Level sensor |
| 3 Pressure gauge in cab | 11 Pressure sensor |
| 4 To load-sensing valve | 12 Tag axle lift bellows |
| 5 Manifold fitting, supply | 13 Pressure limiting valve 8.0 bar |
| 6 Test connection | 14 Front tag axle lift bellows |
| 7 Manifold fitting | 15 Front tag axle solenoid valves |
| 8 Load handling tanks | |

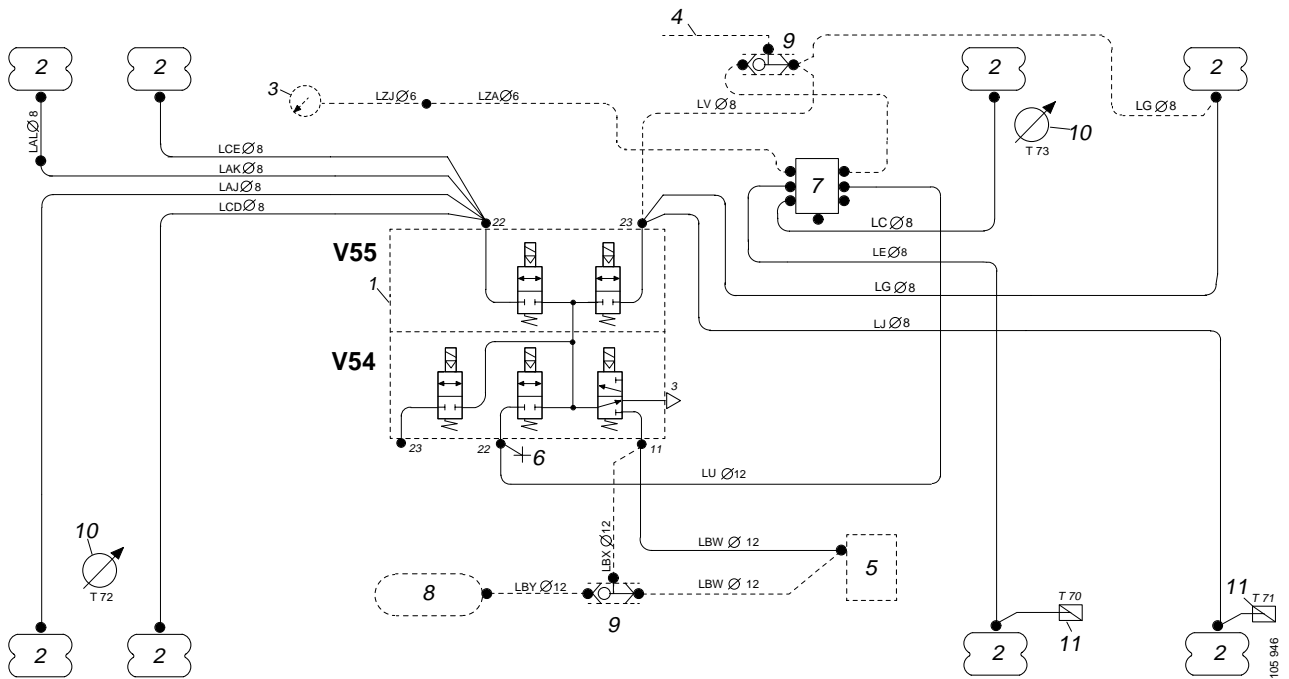
Outline diagram for 8x4B **With** load transfer

- | | |
|----------------------------|-----------------------|
| 1 Solenoid valve block | 7 Manifold fitting |
| 2 Suspension bellows | 8 Load handling tanks |
| 3 Pressure gauge in cab | 9 Double check valve |
| 4 To load-sensing valve | 10 Level sensor |
| 5 Manifold fitting, supply | 11 Pressure sensor |
| 6 Test connection | |

Outline diagram for 8x4*4A **Without** load transfer

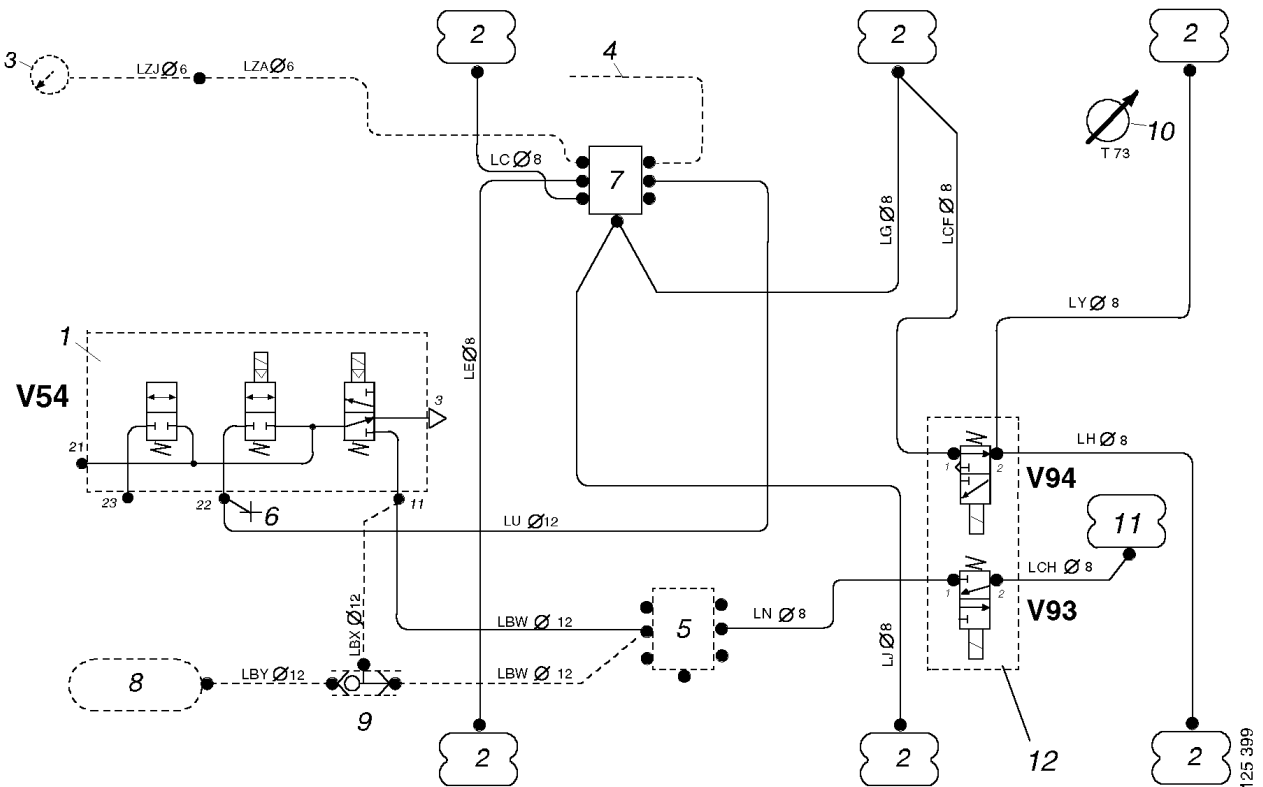

- | | |
|----------------------------|---|
| 1 Solenoid valve block | 7 Manifold fitting |
| 2 Suspension bellows | 8 Load handling tanks |
| 3 Pressure gauge in cab | 9 Double check valve |
| 4 To load-sensing valve | 10 Level sensor |
| 5 Manifold fitting, supply | 11 Tag axle lift bellows |
| 6 Test connection | 12 Tag axle lowering/raising solenoid valve |

cardiagn.com

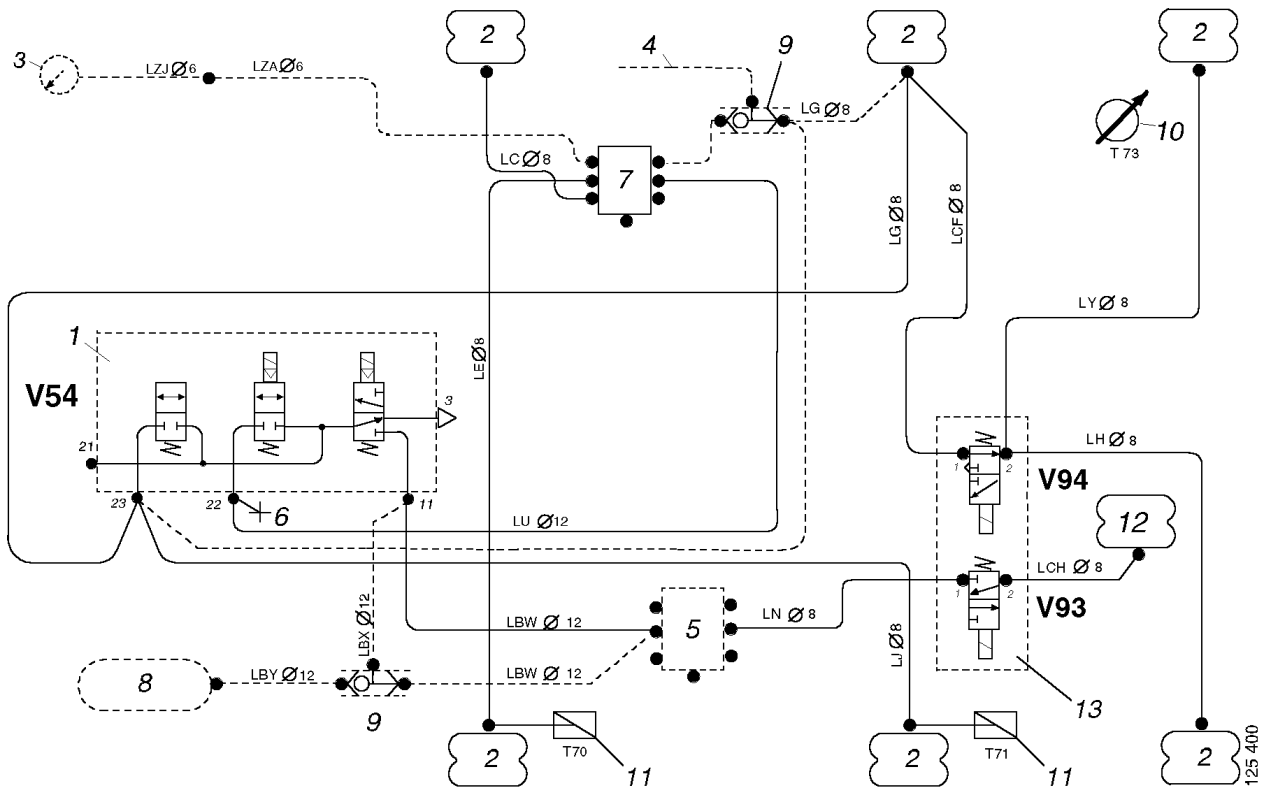
Outline diagram for 8x4*4A **With** load transfer

- | | |
|----------------------------|---|
| 1 Solenoid valve block | 8 Load handling tanks |
| 2 Suspension bellows | 9 Double check valve |
| 3 Pressure gauge in cab | 10 Level sensor |
| 4 To load-sensing valve | 11 Pressure sensor |
| 5 Manifold fitting, supply | 12 Tag axle lift bellows |
| 6 Test connection | 13 Tag axle lowering/raising solenoid valve |
| 7 Manifold fitting | |

Outline diagram for 8x4*4B **Without** load transfer

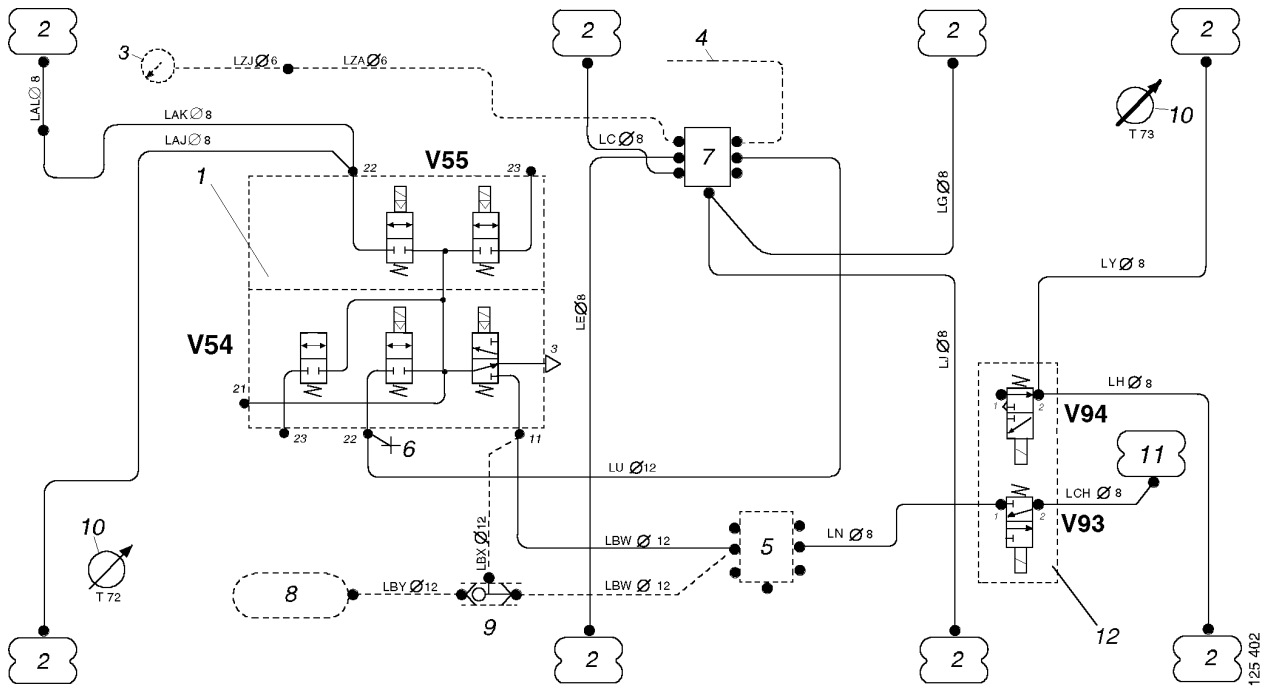

- | | |
|----------------------------|---|
| 1 Solenoid valve block | 7 Manifold fitting |
| 2 Suspension bellows | 8 Load handling tanks |
| 3 Pressure gauge in cab | 9 Double check valve |
| 4 To load-sensing valve | 10 Level sensor |
| 5 Manifold fitting, supply | 11 Tag axle lift bellows |
| 6 Test connection | 12 Tag axle lowering/raising solenoid valve |

cardiagn.com

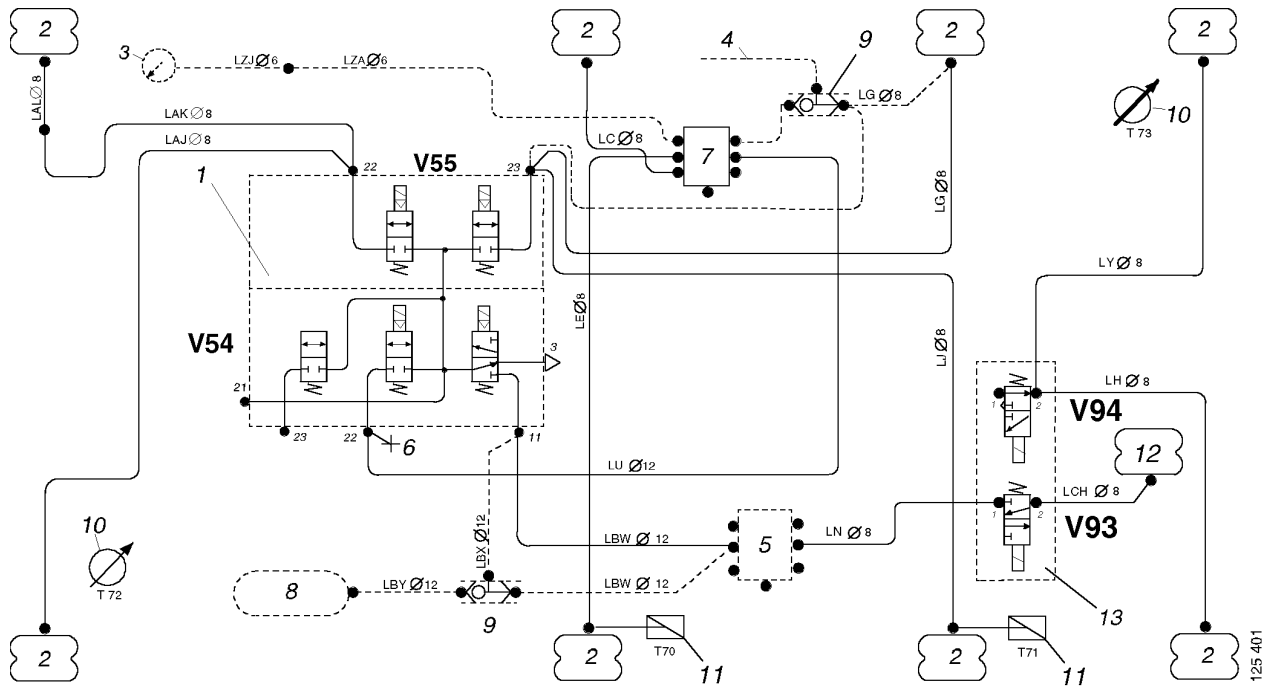
Outline diagram for 8x4*4B **With** load transfer

- | | |
|----------------------------|---|
| 1 Solenoid valve block | 8 Load handling tanks |
| 2 Suspension bellows | 9 Double check valve |
| 3 Pressure gauge in cab | 10 Level sensor |
| 4 To load-sensing valve | 11 Pressure sensor |
| 5 Manifold fitting, supply | 12 Tag axle lift bellows |
| 6 Test connection | 13 Tag axle lowering/raising solenoid valve |
| 7 Manifold fitting | |

Wiring diagram

Components

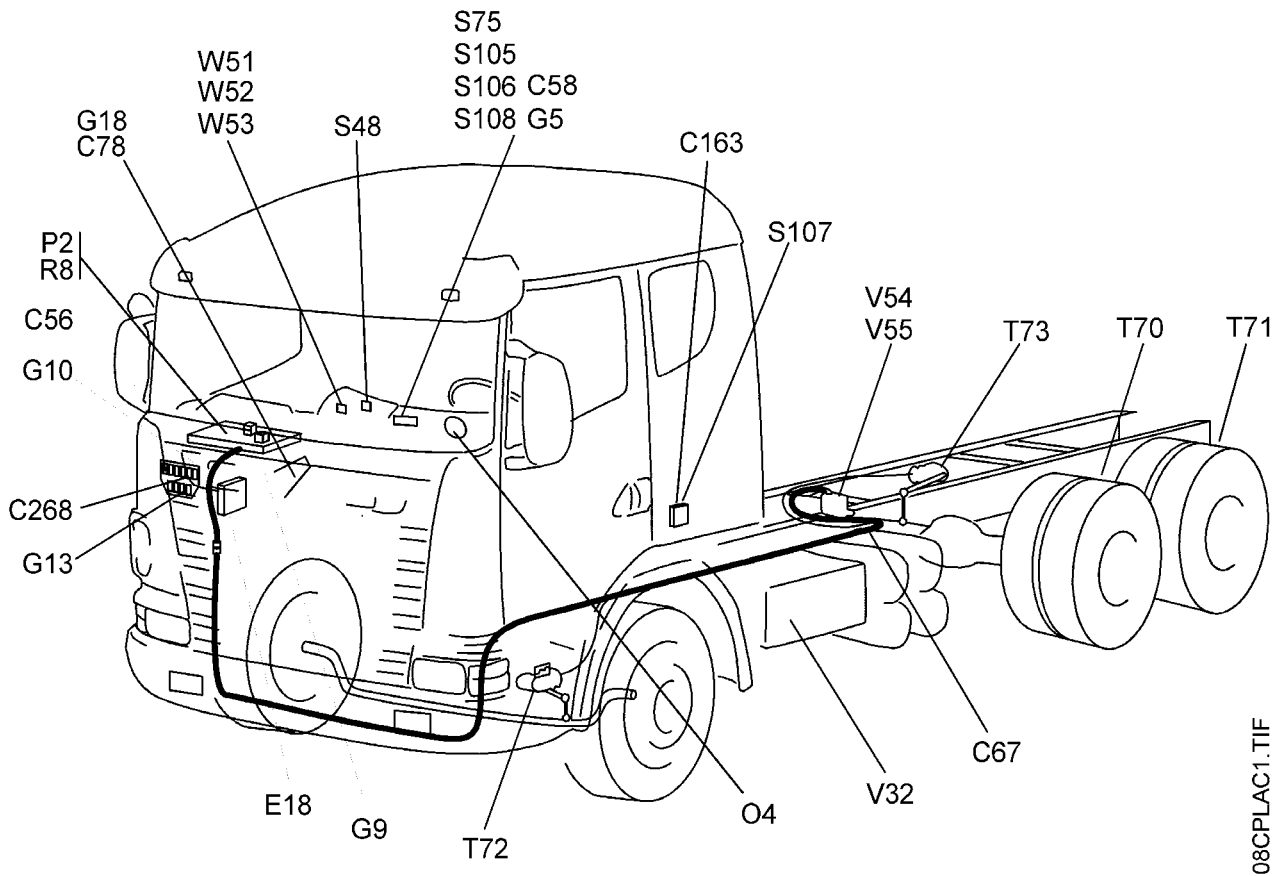

cardiagn.com

Components

Component	Function
C56	Distribution terminal, 18-pin
C58	Connector, 2-pin
C67	Union point for solenoid valve earth cables
C78, C163	Connector, 9-pin
C268	Connector, 17-pin
E18	Control unit
G5, G9, G10, G13, G18	Earthing points
O4	Tachograph
P2	Central electrical unit
R8	Brake light relay
S48	Diagnosis switch
S75	Temporary drive level switch
S105	Load transfer/tag axle lift switch
S106	Load transfer switch (with time limiter)
S107	Control box
S108	Load transfer switch (without time limiter)
T70, T71	Pressure sensor for rear axle and tag axle/rear rear axle
T72, T73	Level sensor, front and rear
V32	Parking brake release solenoid valve
V54, V55	Solenoid valve block
W51	Warning lamp for level fault
W52	Warning lamp for system fault
W53	Warning lamp for load transfer

Current path 51 - 75

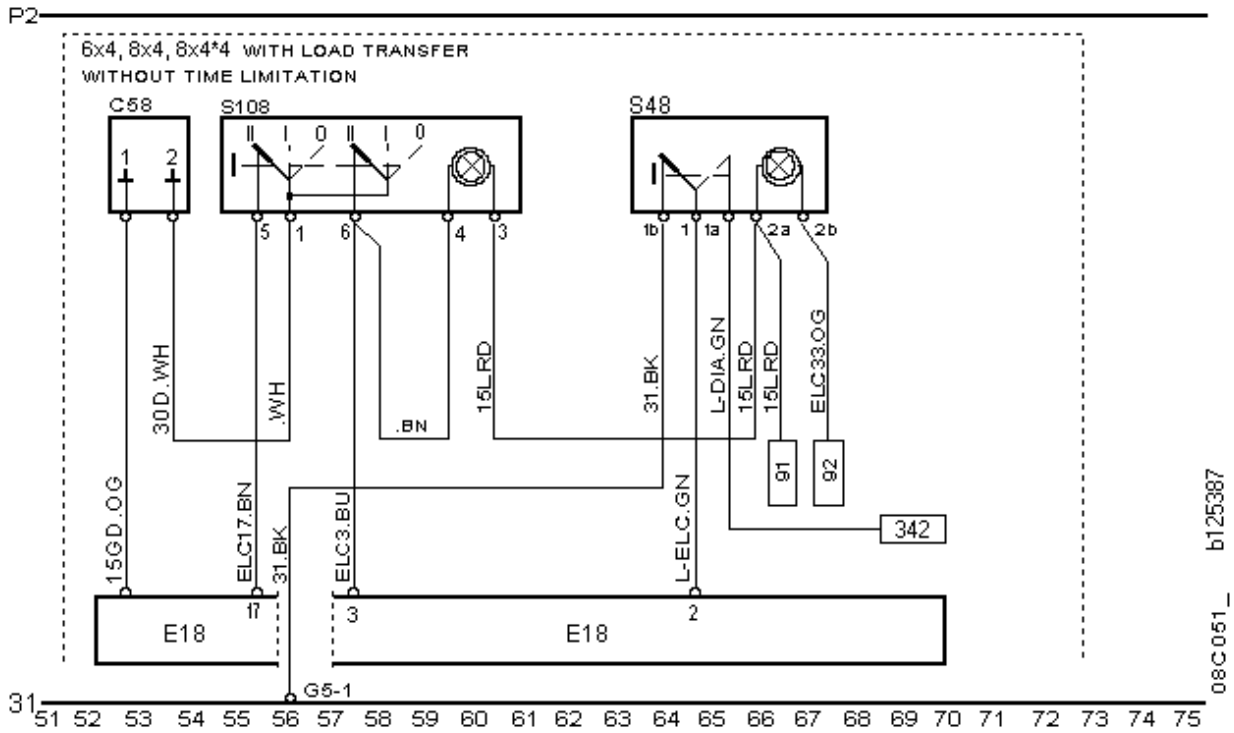

Current path 76 - 100

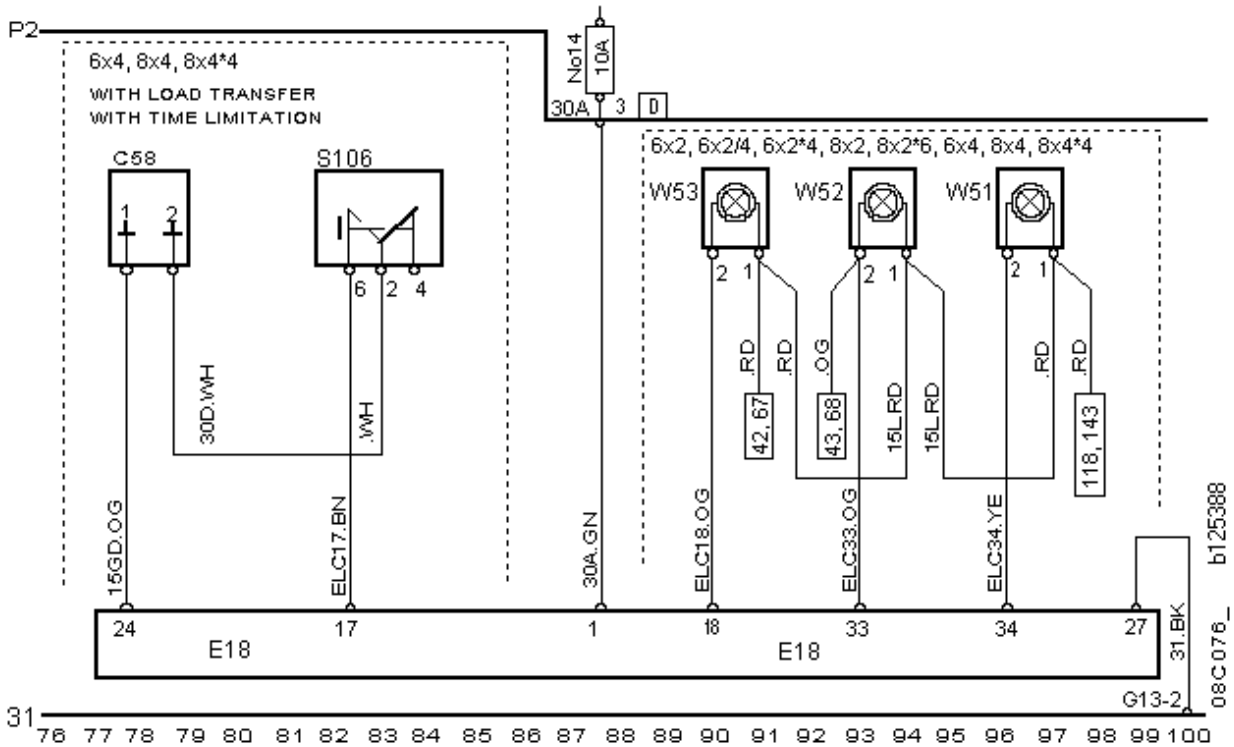

Current path 101 - 125

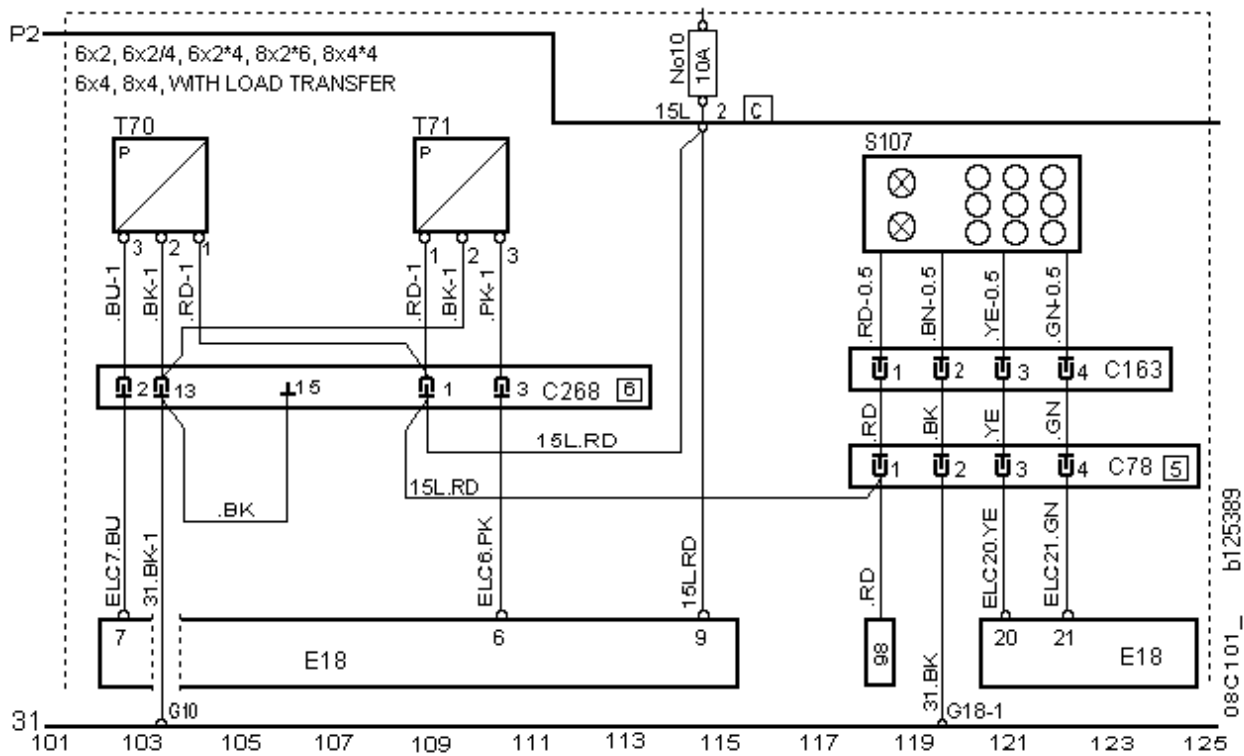

Current path 126 - 150

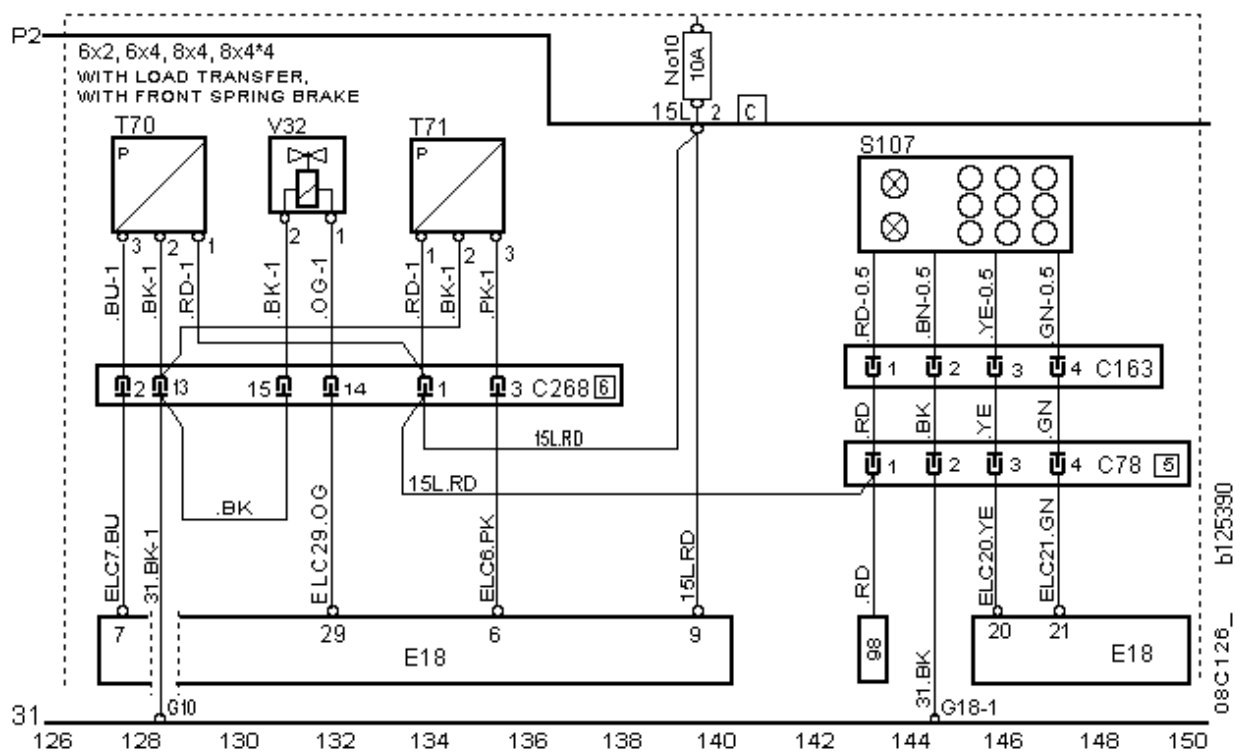

Current path 151 - 175

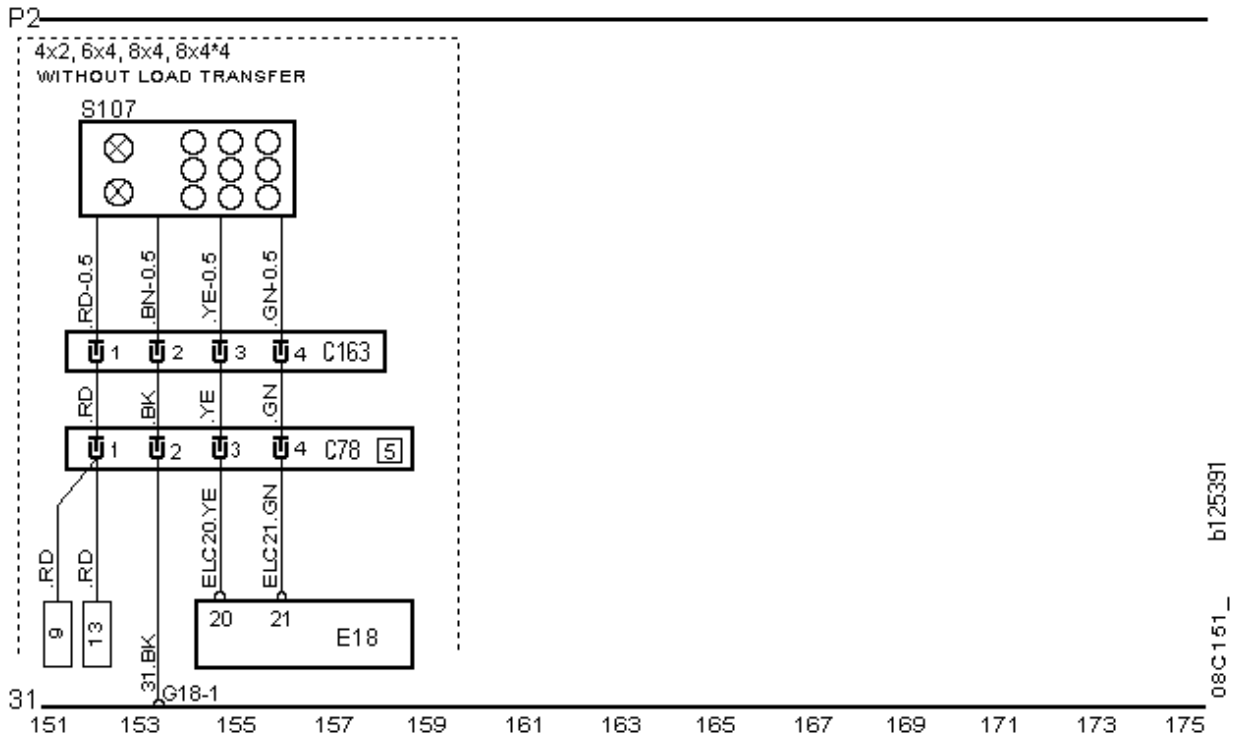

Current path 176 - 200

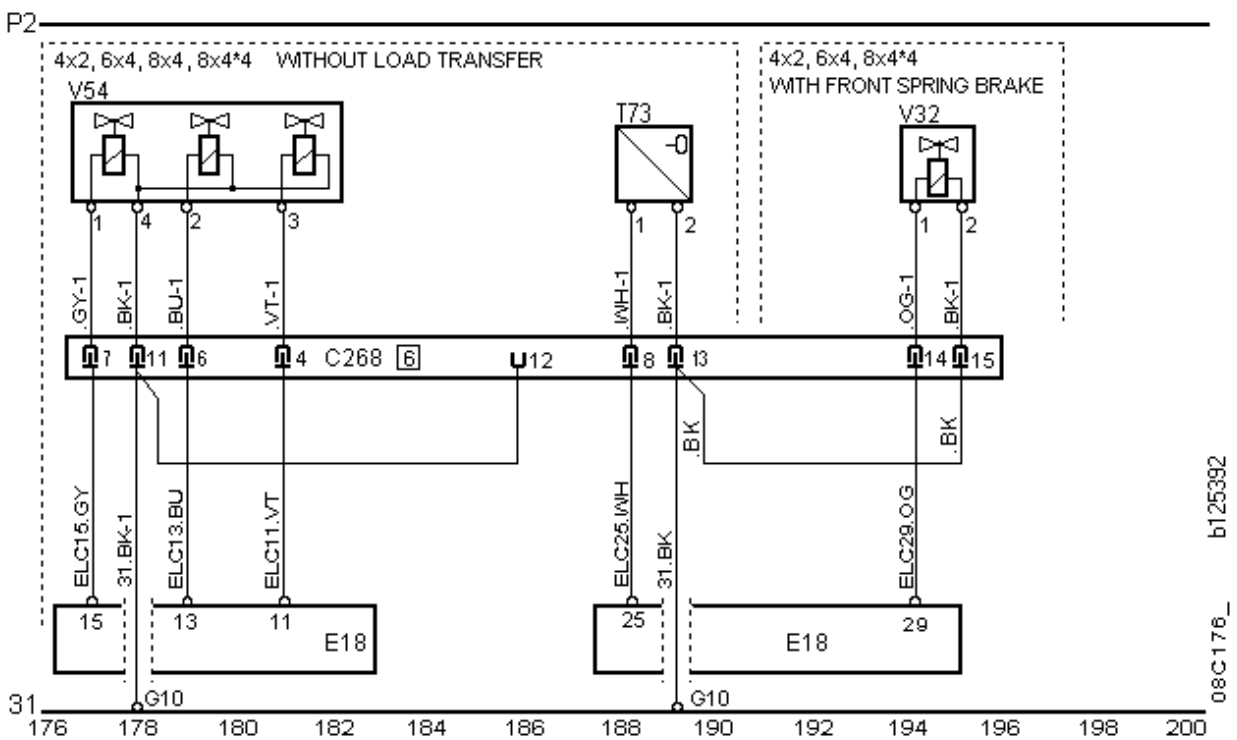

Current path 201 - 225

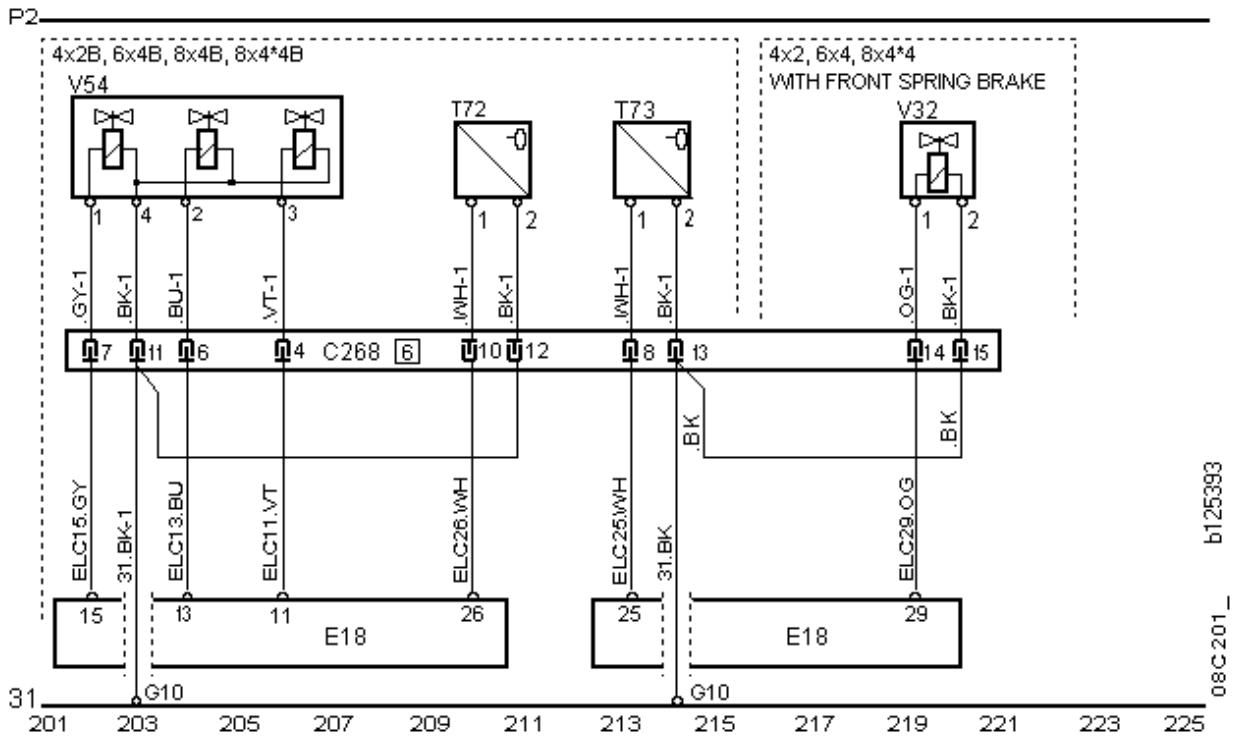

Current path 226 - 250

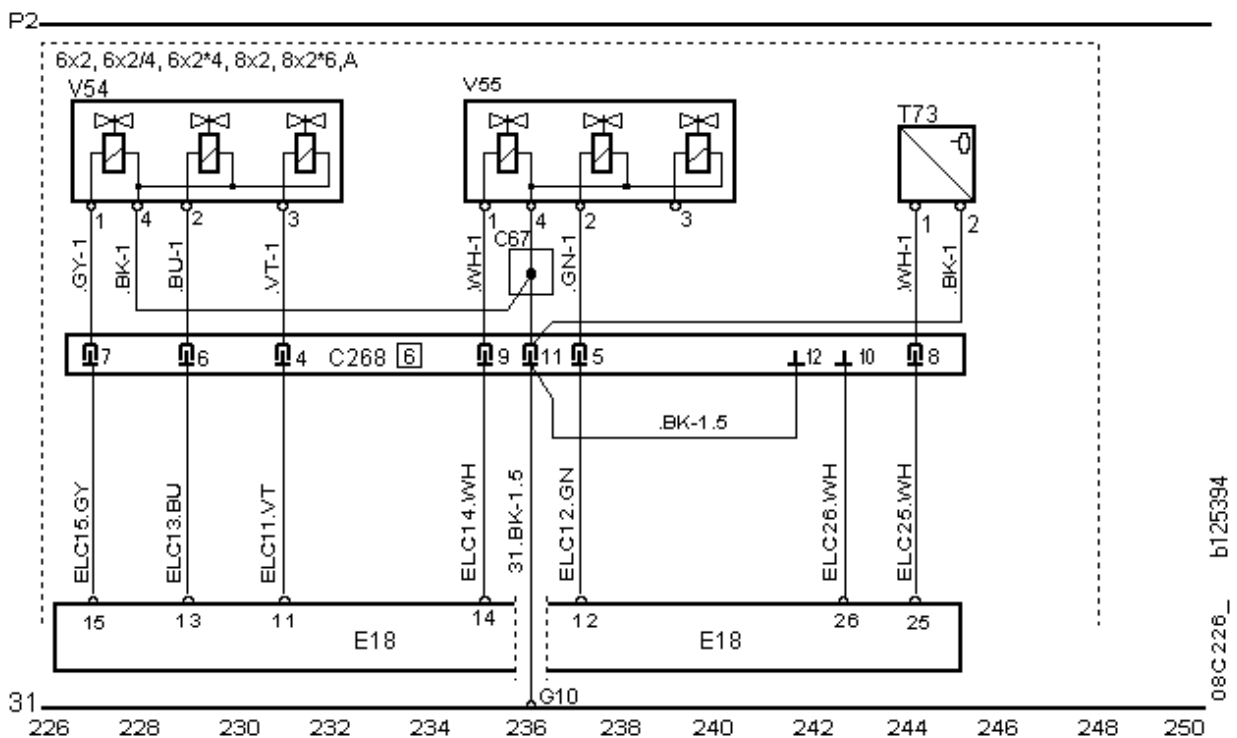

Current path 251 - 275

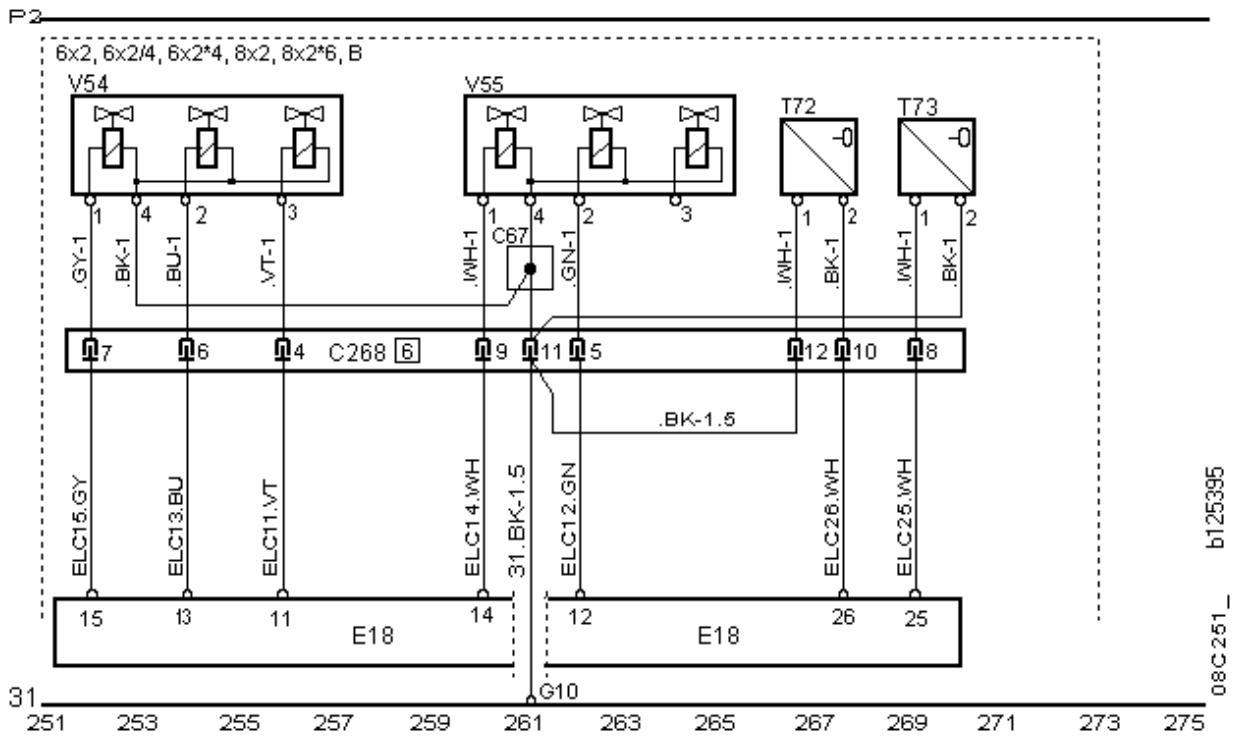

Current path 276 - 300

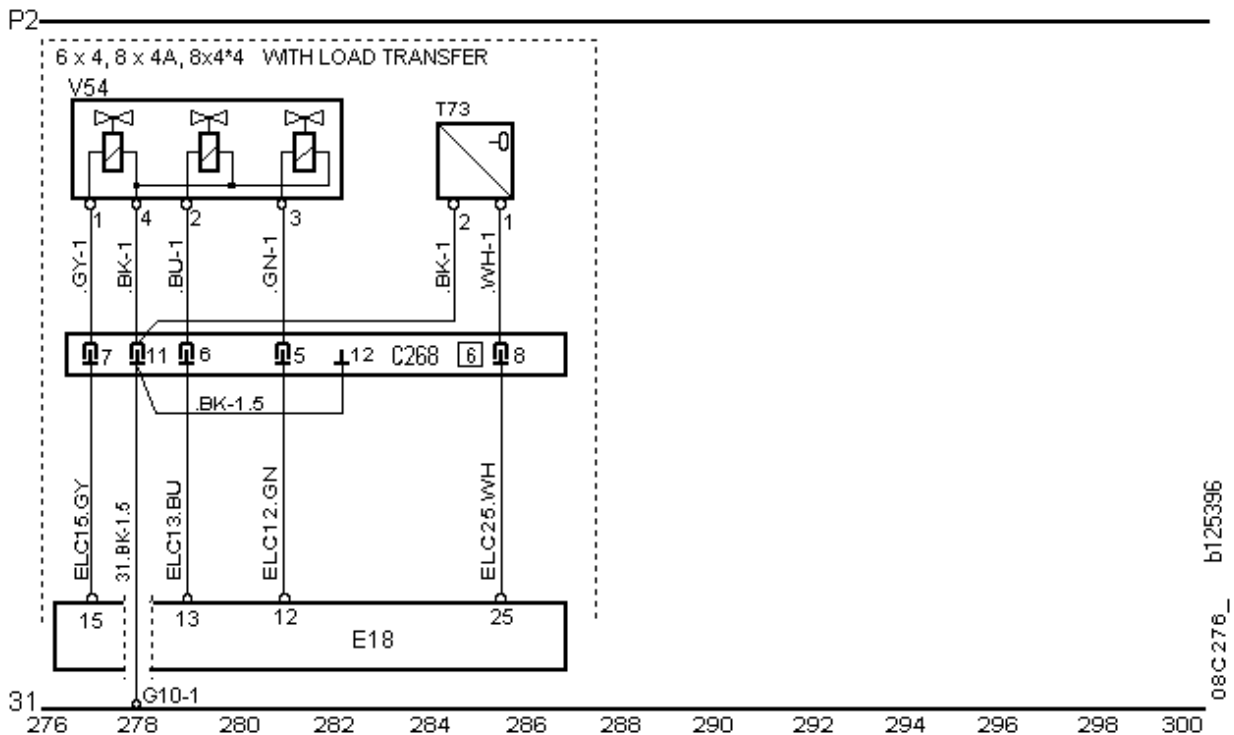

Current path 301 - 325

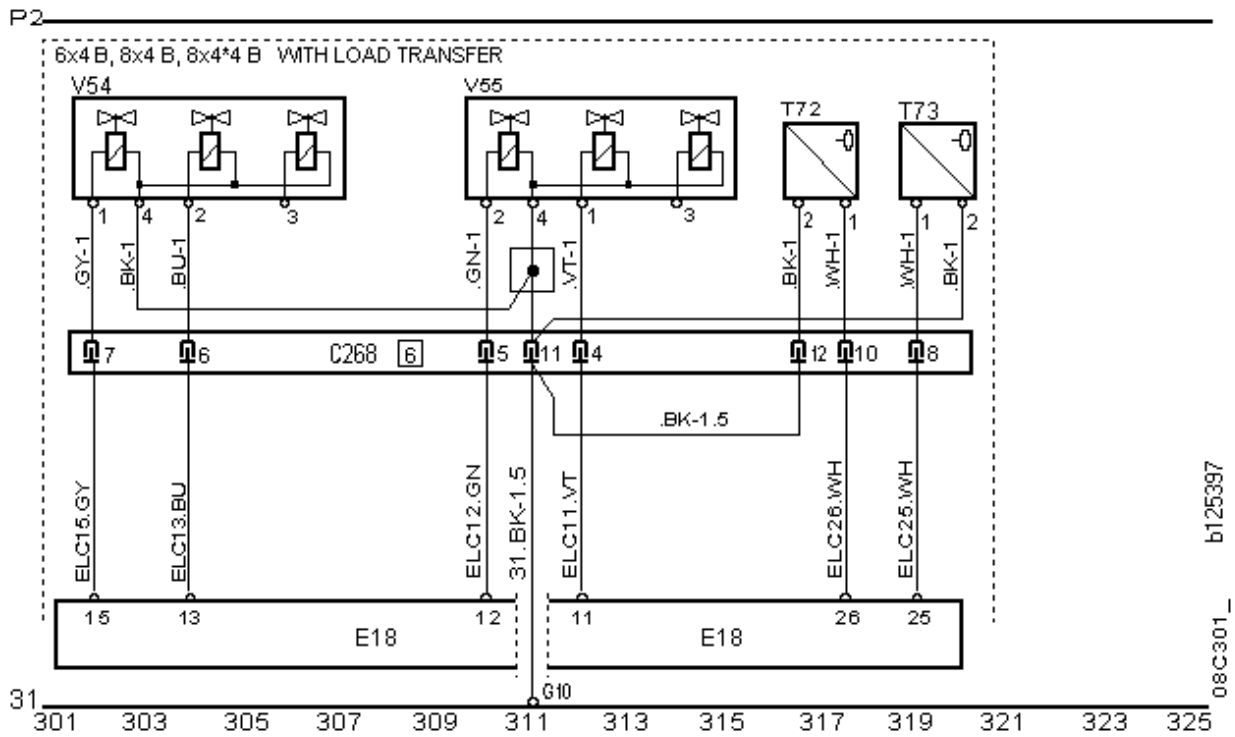

Current path 326 - 350

