

**SCANIA**

**12:03-07**

Issue 3 en

## ELC generation 2

### Description and Operation

With updates concerning the new ELC generation 2.1A control unit, introduced 98-08.

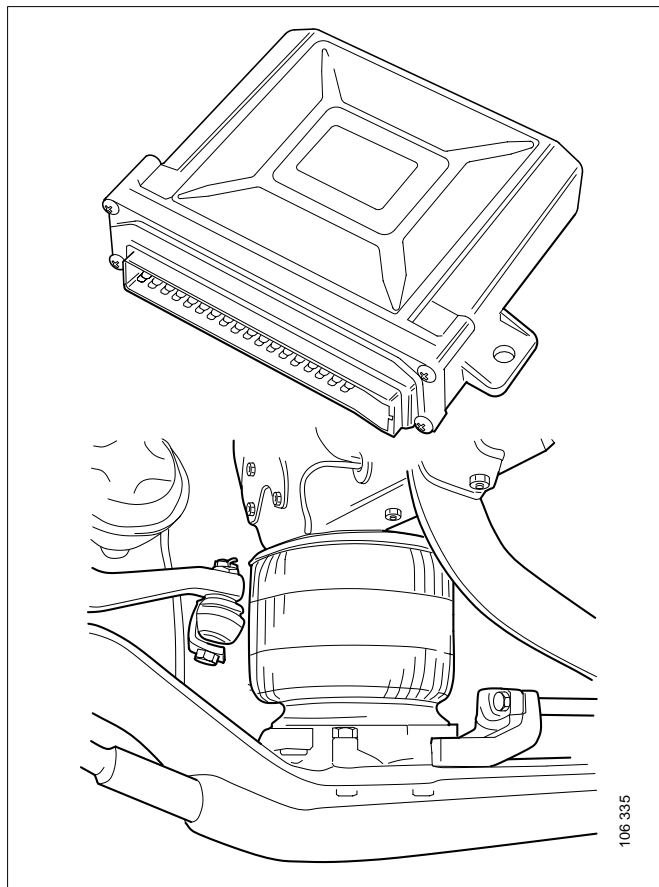

## Contents

<b>Safety</b>	Working under vehicles with air suspension.....	5
	Driving vehicles with air suspension .....	5
<b>System overview</b>	Introduction.....	6
	Changes.....	6
	Identifying system generation.....	7
<b>System description</b>	.....	8
	Axle weight distribution.....	8
	Parking brake .....	8
<b>Drive level</b>	Normal .....	9
	Elevated.....	9
	Temporary .....	9
	Tie down position.....	9
<b>Control</b>	Quick control .....	10
	Normal control.....	10
	Braking.....	10
<b>Controls and operation</b>	.....	11
<b>Vehicles with tag axle</b>	Switch for tag axle lift and load transfer.....	11
	Tag axle lift .....	11
	Tag axle lift process .....	12
	Load transfer .....	12
	Vehicles with two tag axles.....	13
<b>Vehicles with tandem bogie</b>	Switch .....	13
	Differential lock during load transfer.....	13

**Contents cont.**

<b>Load transfer</b>	.....	14
	With time limit.....	14
	Without time limit.....	15
	Load transfer process.....	15
	Speed limit.....	15
<b>Configuration</b>	Configuration groups .....	16
<b>Alternative configurations</b>	Basic .....	16
	Quick operation .....	16
	Load handling.....	16
<b>Control box</b>	.....	17
	Vehicles with A suspension .....	18
	Standby .....	18
	Activating Standby .....	18
	Programming M1 and M2 .....	18
	Level adjustment.....	18
<b>Electrical system</b>	Control unit.....	20
	Input and output signals.....	20
	Control unit connections.....	20
	Replacement of control unit .....	22
	Calibration .....	22
<b>Warning lamps</b>	System fault .....	22
	Level fault.....	23
	Load transfer.....	23

**Contents, cont.**

<b>Valves and sensors</b>	.....	25
Solenoid valve block	Solenoid valve block V54 .....	25
	Solenoid valve block V54+V55 .....	27
Solenoid valve	Solenoid valve V32 .....	29
Level sensor	Level sensor T72 and T73 .....	29
Pressure sensor	Pressure sensor T70 and T71 .....	31

# ELC generation 2

## Safety

### Working under vehicles with air suspension

Work under vehicles with air suspension must be performed in such a way that there is no risk of personal injuries.

If the frame drops on to the axle there is a risk of injuries by pinching or impact.



**WARNING!**

**Always use stands to support the vehicle when working under vehicles with air suspension.**

### Driving vehicles with air suspension

When driving, the vehicle should be at its calibrated Normal drive level. To set the normal drive level, press the green button on the control box. However, before pressing the green button, press at least one of the buttons for raising or lowering (front or rear). When the buttons for raising or lowering have been pressed, the lamps on the control unit will illuminate.

When the normal drive level has been reached, the level fault warning lamp will go out. It is located in the instrument panel. Only in exceptional cases should the vehicle be driven at a level other than the normal drive level.

The frame may drop on to the axle if:

- An air bellows is punctured:
- An air line is disconnected.
- Voltage is applied to a valve for the purpose of emptying the bellows.
- A level valve is operated when the starter voltage is on.

# System overview

## Introduction

ELC gen 2 (Electronic Level Control) is an electronic control system for the vehicle air suspension. ELC gen 2 offers a number of advantages as compared with mechanically controlled air suspension:

- Level control regardless of vehicle height. Vehicle maintains constant height during loading and unloading.
- Reduced air consumption while driving.
- Improved load transfer function for three-axle vehicles.
- Less complex air line and valve system.
- Drive level is not affected when braking and cornering.
- Standby function.
- Possibility of using temporary drive level.

## New control unit ELC 2.1A

As from 98-08, a new control unit is introduced into production. The new control unit is designated ELC generation 2.1A. For spare part purposes, the new control unit replaces the old 2nd generation control unit.

## Changes

Differences between ELC gen 2 and ELC gen 1:

- One control unit is used for all vehicle types.
- Standby function is available for all vehicle types.
- The rear axle weight distribution is controlled by means of pressure sensors in the rear axle suspension bellows.
- Automatic release of the front axle parking brake during load handling (applies to all vehicles with front spring brakes).
- Elevated drive level can be selected during load transfer.
- The tag axle lift switch always returns from its upper position.
- New bayonet type connectors for all electrical connections, in compliance with DIN.
- New type of solenoid valve block. Four different variants with 2 - 5 functions depending on vehicle type. Only the three and five function types are available as spare parts. Outlets that are not used must be plugged.
- The solenoid valves in the valve blocks are of a new type, where two or three coils are integral to a cassette with a common connector. Only the three coil type is available as spare part. When used in a valve block with only two functions, the third coil will not be used.

## Generation 2.1A

The most important changes to the new control unit do not affect system operation or system repairs. Some differences in system function have been introduced as described below:

- Possibility of control unit configuration read out by means of Scania Programmer 2 and Scania Diagnos 2.
- Possibility of shutting off automatic tag axle lowering when maximum permissible rear axle weight during tag axle lift has been reached.
- Possibility of using Control box also when load transfer is activated.
- The control unit has a memory function, which records if load transfer is activated and tag axle is raised when starting voltage is shut off.

## Identifying system generation

The easiest way of identifying what ELC generation the vehicle is equipped with is by the location of the shock absorbers. On ELC gen 2, the rear shock absorbers are located on the outside of the frame.

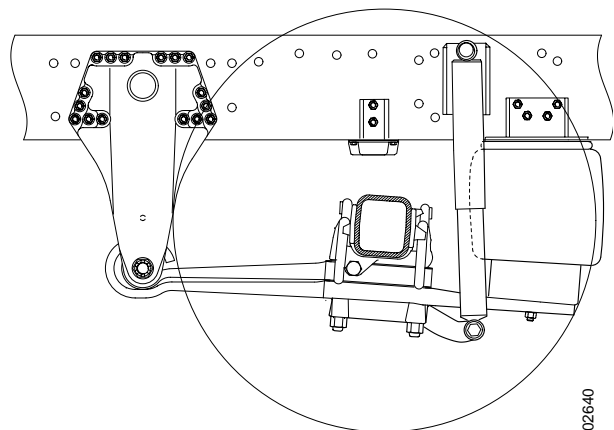

*Identifying system generation. The shock absorbers are located on the outside of the frame.*

102640

## Generation 2.1A

The easiest way of identifying whether the vehicle is fitted with a control unit of type generation 2 or 2.1A is by means of Scania Diagnos or Programmer.

### System description

The control unit continuously registers the vehicle height by means of level sensors. One to the rear and one to the front (on vehicles with B suspension).

When a level adjustment is required, the control unit adjusts the air quantity in the bellows by way of a solenoid valve block.

When braking, a signal is sent from the brake lamp relay to the control unit. This signal is used to avoid unnecessary level adjustments.

The speed signal from the tachograph is used to inform the control unit that the vehicle is in motion. When driving, the ELC uses normal control and consumes considerably less air than when the vehicle is stationary.

The body height can be changed by way of the control box. The control unit adjusts the level up or down as long as one of these buttons is pressed.

Tag axle lift and load transfer are controlled by means of the pressure sensors on the rear axle suspension bellows. By continuously sensing the pressure in the bellows, optimum control and distribution are achieved.

### Axle weight distribution

On vehicles with bogie and load transfer, the axle weight distribution is continuously monitored by the control unit by way of two pressure sensors. One on each rear axle. The sensors sense the pressure in the suspension bellows and enable the control unit to distribute the weight between the axles according to programmed values.

### Parking brake

On vehicles with front spring brakes, the front parking brake is released automatically during load handling to the rear or during tag axle lift as well as load transfer. Brake release is by the control unit opening a valve, which fills the parking brake cylinders with air. This prevents undesired bending stress on the frame when raising or lowering the vehicle.

The function Release parking brake is interrupted in the following cases:

- Tachograph fault sensed by the control unit.
- Control unit senses a speed signal.
- Stop button on control box is pressed.
- Normal drive level has been reached.
- M1 or M2 has been reached.
- Raising or lowering the tag axle is completed.
- Rear raising/lowering is shut off by way of the control box.

In standby state the parking brake is applied.

Before the control unit has been calibrated, automatic brake release does not function.



## Drive level

### Normal

The normal drive level level at which the vehicle is normally driven. When the vehicle is not at the normal drive level, the level fault warning lamp will be on.

The vehicle height is automatically set to normal drive level when the green button on the control box is pressed after one of the buttons for raising or lowering the vehicle has been pressed (refer to section Control box).

The normal drive level is programmed into the control unit during level calibration. Calibration must be performed each time the control unit, a pressure sensor or level sensor is renewed.

If the vehicle level changes when the starting voltage is off, e.g. due to leakage, the vehicle will not resume the normal drive level when the voltage is switched on. In this case the normal drive level must be set by means of the control box.

### Elevated

When tag axle lift or load transfer has been requested, the normal rear drive level will be raised. On delivery of the vehicle, the control unit is programmed to 65 mm on tag axle lift and 20 mm on load transfer as measured at the rear level sensor. These levels may be changed according to customer request, using Scania Programmer 2, version 2.02 or later.

### Temporary

The temporary drive level can be set by an additional switch fitted in the cab. This function is useful when a higher or lower drive level is desired for a limited time.

When e.g. operating a crane, this function can be used to empty the bellows completely.

The switch signal shall be connected to pin 19 on the control unit.

The temporary level is then set by means of Scania Programmer 2, version 2.02 or later. Refer to Work Description.

This function comes as standard on certain vehicle types.

### Tie down position

When the vehicle is secured onboard a ferry, it shall be lowered to the bump stops by way of the control box. This level is maintained when the starting voltage is switched off.

### Control

#### Quick control

When the vehicle is stationary and the starting voltage is on, ELC controls the level at 1.5 second intervals, so-called quick control. This ensures that the vehicle maintains the set level during loading and unloading.

The quick control is also in operation when Standby is activated.

#### Driving with quick control

The quick control is normally interrupted when the control unit senses a speed signal from the tachograph.

On delivery, the control unit is programmed to interrupt quick control at 15 km/h on 4x2 vehicles and at 0 km/h on other vehicles.

Using Scania Programmer 2 it is, however, possible to select a speed limit (0, 15 km/h), below which the control unit uses quick control.

On 4x2 vehicles the setting cannot be changed.

#### Generation 2.1A

On control units of generation 2.1A, the speed limit for quick control can be set to 0, 15 or 100 km/h.

On 4x2 vehicles, the speeds 15 or 100 km/h can be selected.

100 km/h in practice means unlimited speed for quick control.

#### Normal control

When driving, ELC uses normal control, the level being checked and adjusted as necessary once a minute. This is to avoid unnecessary control during e.g. cornering or acceleration. When normal control is used, ELC consumes considerably less air than a mechanical air suspension.

#### Braking

During braking, the brake lamp relay emits a signal to the control unit, which interrupts all level control. This prevents the system from adjusting for changes in the level that are caused by the vehicle forward inclination when braking.

# Controls and operation

## Vehicles with tag axle

### Switch for tag axle lift and load transfer

On the instrument panel there is a three way switch (S105) for operating the tag axle.

When the button is in centre position the tag axle is up.

To lower the tag axle the button shall be pressed to its lower, fixed position.

When the button is pressed to its upper, spring back position, load transfer is activated.

Old configuration:

The lamp integrated in the button is on when tag axle lift or load transfer has been requested. The lamp goes out when the button is pressed to its lower position.

New configuration:

The lamp in the button illuminates when tag axle lift is activated and goes out when tag axle lowering is activated. Thus, the lamp indicates that the control unit has approved that the tag axle can be lifted.

Switch

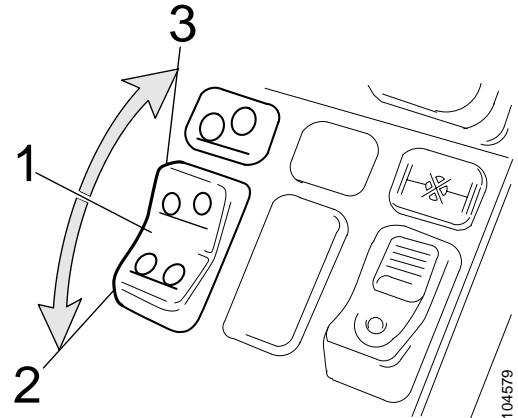

Three way switch (S 105)

### Tag axle lift

When tag axle lift has been requested, air is let out from the tag axle suspension bellows. The tag axle is lifted provided that the maximum rear axle weight is not exceeded and that sufficient system pressure is available. The lamp in the switch illuminates.

Before a new attempt at lifting the tag axle can be made, the button must be pressed to its lower position.

If the maximum rear axle weight is exceeded during loading with the tag axle lifted, the tag axle will be automatically lowered. This automatic lowering can be disabled by means of Scania Programmer 2 by selecting Manual for the function Lowering of lifted tag axle.

Maximum rear axle weight will vary between countries due to differences in legal requirements and is programmed by means of Scania Programmer 2.

### Tag axle lift process

Following a request for tag axle lift, the process is as follows:

- 1 The control unit decides, based on the specified maximum rear axle weight, whether tag axle lift is possible. If no lift is possible, the process ends. If lift is possible, the process continues according to para. 2.
- 2 The rear axle suspension bellows are pressurized in order to raise the level somewhat. In the following paras the system operates in stages.
- 3 The tag axle lift bellows are partly filled.
- 4 The tag axle suspension bellows are vented.
- 5 The tag axle lift bellows are filled more.
- 6 The venting of the tag axle suspension bellows continues.
- 7 The tag axle lift bellows are filled again.
- 8 The control unit checks whether the pressure is rising in the tag axle suspension bellows. The pressure rise indicates that lifting is in progress and that the tag axle is not completely up.
- 9 If the pressure is rising, the process continues according to para. 7, if not, lifting ends.

**Note!** When the tag axle is up, the lifting bellows are filled again every five minutes to compensate for leakage.

### Load transfer

All types of vehicles with tag axle are standard equipped with load transfer. Due to differences in legal requirements, the load transfer is available in two different configurations, with or without time limit. It can also be programmed with a speed limit for load transfer. These functions are programmed by means of Scania Programmer 2. For further information, refer to section Load transfer.

## Vehicles with two tag axles

On 8x2/4 vehicles with A or B suspension and two tag axles, the front tag axle is controlled by way of a separate switch on the instrument panel. This function is entirely manual and is independent of the ELC control unit.

The switch controls two solenoid valves (V71 and V72). V72 empties the suspension bellows at the same time as V71 fills the tag axle lifting bellows when tag axle lift has been requested.

The valves are located to the left on the crossmember in front of the lifting bellows for the front tag axle.

### Switch

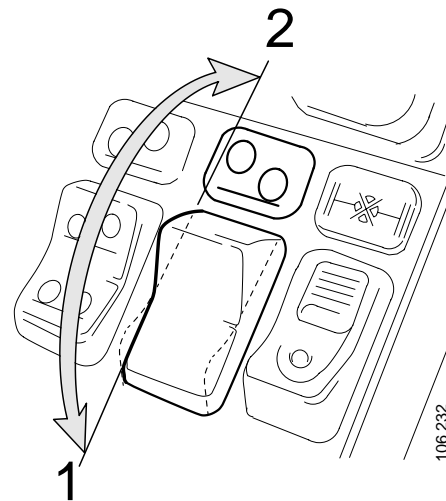

*Two way switch with fixed positions (S11).*

## Vehicles with tandem bogie

Vehicles with tandem bogie are available with and without load transfer. The load transfer may be with or without time limit.

### Switch

For vehicles with tandem bogie, two switch configurations are available. Two way switch for vehicles with time limited load transfer (S 106) and three way switch (S 108) for other vehicles.

When the button is not pressed, load transfer is not activated and bogie weight distribution is according to specification.

### Differential lock during load transfer

It is not possible to activate load transfer until the bogie differential lock has been activated. For further information, refer to section Load transfer.

### Switch

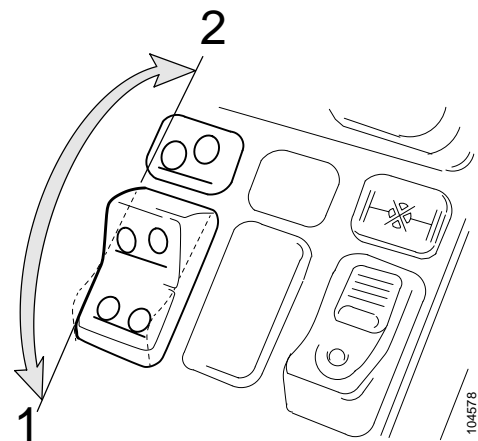

*Two way switch (S 106).*

## Load transfer

Load transfer is used for temporarily increasing the weight on the front rear axle, e.g. to provide better traction.

When load transfer has been requested, the tag axle or rear rear axle suspension bellows are gradually vented. If maximum rear axle weight is not obtained in load transfer, the tag axle/rear rear axle suspension bellows will be completely emptied.

The regulations for maximum permissible rear axle weight and load transfer are governed by legal requirements in the countries concerned. These requirements must be considered when programming the control unit.

When load transfer has been activated, the control box does not function until the control box stop button has been pressed and load transfer has been interrupted.

The load transfer warning lamp illuminates when load transfer is requested and is on as long as the load transfer is activated.

### Generation 2.1A

The control box function is not influenced by load transfer with generation 2.1A. Thus, the control box can be operated also during load transfer. In addition, load transfer can be activated when the control box is activated.

A memory function has also been added to the control unit. When the starting voltage is switched off and on again, the control unit remembers whether load transfer was activated when the starting voltage was switched off. Load transfer is then activated automatically. However, this will only occur if complete load transfer with tag axle lift has been performed.

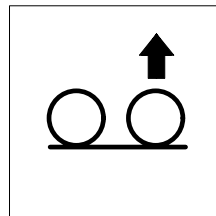

*Load transfer warning lamp*

### With time limit

When the button is pressed to its upper position, load transfer is activated for 90 seconds and the load transfer lamp in the instrument panel illuminates. The lamp in the button also illuminates (for further information, refer to Controls and operation, Switch for tag axle lift).

Load transfer is always performed to the programmed permissible level.

After 90 seconds and when the load transfer phase is completed, the lamp goes out.

A renewed load transfer cannot be started until 50 seconds after load transfer is completed.

Load transfer on vehicles with tandem bogie is not enabled until the bogie differential lock has been activated.

## Without time limit

On vehicles with load transfer without time limit, load transfer can be controlled steplessly. When the tag axle lift button is pressed to its upper position, load transfer starts and the load transfer lamp in the instrument panel illuminates.

Load transfer continues as long as the button is pressed. When the button is released, load transfer stops and the transfer level achieved is maintained.

If the button is pressed again, load transfer continues until maximum rear axle weight is achieved. If maximum rear axle weight is not achieved when the tag axle suspension bellows are completely vented, the tag axle will be lifted, provided that the control unit is programmed for Load transfer with tag axle lift.

When the button is then pressed to its lower position and held down, load transfer decreases until the lamp in the instrument panel goes out. Then, load transfer is completed.

If the button is brought to its centre position before the load transfer lamp has gone out, the load transfer reduction stops and the current bogie weight distribution is maintained.

## Load transfer process

Following a request for load transfer, the process is as follows:

- 1 The rear axle suspension bellows are pressurized in order raise the level. The load transfer lamp illuminates.
- 2 The tag axle suspension bellows are vented. Then, the rear axel suspension bellows are pressurized again to achieve the correct drive level.
- 3 Para. 2 is repeated until the specified value for Maximum rear axle weight during load transfer is achieved.
- 4 If all weight has been transferred to the rear axle before the specified value for Maximum rear axle weight during load transfer is achieved, tag axle lift will start, provided that the control unit is programmed for Load transfer with tag axle lift. Refer to section Tag axle lift process.

**Note:** Para. 4 does not apply to vehicles with time limited load transfer.

**Note:** During load transfer the level fault lamp may illuminate temporarily. The lamp goes out when the correct level is achieved.

## Speed limit

To comply with national legal requirements for e.g. 6x2/4 vehicles, it is possible to program a maximum permissible speed during load transfer. This limit is programmed by means of Scania Programmer version 2.02 or later and means that load transfer is interrupted when vehicle speed exceeds 25 km/h.

# Configuration

## Configuration groups

The vehicles in a configuration group are largely equipped in the same way. There are three different vehicle configuration groups:

- Vehicles without load transfer: 4x2, 6x4, and 8x4.
- Vehicles with load transfer: 6x4 and 8x4.
- Vehicles with tag axle and load transfer: 6x2, 6x2/4, 6x2\*4, 8x2, 8x2\*6, and 8x2/4.

In addition, the vehicles are available with A or B suspension.

These groups are used by Scania Diagnos 2 for identifying vehicles.

## Generation 2.1A

The new control unit does not make use of configuration groups since the exact wheel configuration is stored in the memory.

### S order

Vehicles built to S order may have a wheel configuration that is not supported by Scania Programmer 2 (SP2). These vehicles shall be programmed with one of the wheel configurations supported by SP2. It is important to select the correct wheel configuration. The chassis card states what wheel configuration to use when programming vehicles built to S order.

## Alternative configurations

In combination with ELC gen 2 three alternative compressed air system configurations are available.

There may be some restrictions as regards combinations of the compressed air system configuration.

### Basic

- A or B suspension.

Basic has the following specification:

- 9.3 bar system pressure.
- No extra air tanks.

### Quick control

Quick control is available on vehicles with the following specification:

- A or B suspension.

Quick control has the following specification:

- 12.2 bar system pressure.
- 2 extra air tanks.

### Load handling

Load handling is available on vehicles with the following specification:

- B suspension.
- Wheel configuration 4x2, 6x2, 6x4, and 6x2\*4.

Load handling has the following specification:

- 12.2 bar system pressure.
- 4 extra air tanks (4x2).
- 6 extra air tanks (6x2, 6x4, and 6x2\*4).

There may be some restrictions in the above data due to axle distance and chassis height.



# Control box

## Operation

The control box allows the vehicle to be raised or lowered to the desired level. The control box contains a separate microprocessor. The control box communicates with the control unit by digital signals.

There are nine buttons and two lamps on the control box. The left lamp indicates if button No. 2 is activated and the right lamp indicates if button No. 3 is activated (see illustration). Button No. 4 is not used.

The vehicle can be driven although the lamps are on.

The vehicle may be driven at a manually set level. However, Scania recommends that the vehicle always be driven at Normal drive level.

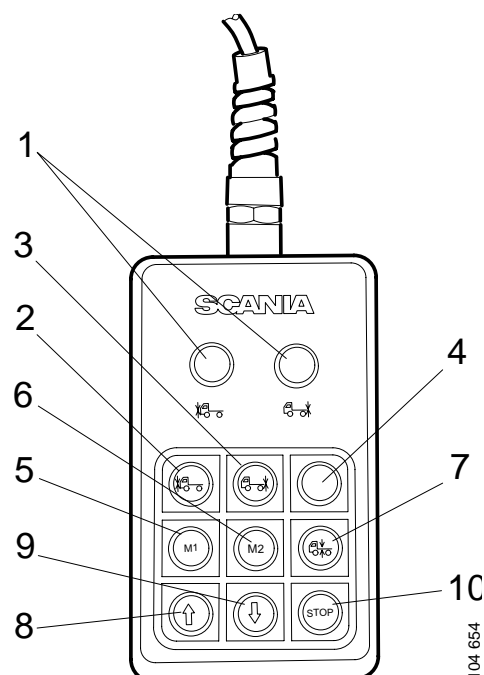

*The buttons and lamps of the control box.*

### Buttons of the control box.

- 1 Lamps indicating if buttons Nos 2 or 3 (raise or lower, front or rear) are activated.
- 2 Activate function: raise/lower front.
- 3 Activate function: raise/lower rear.
- 4 Not used.
- 5 M1 - Memory for individually programmed level. Must be used in combination with button No. 2 and/or 3.
- 6 M2 - Memory for individually programmed level. Must be used in combination with button No. 2 and/or 3.
- 7 Set normal drive level - Must be used in combination with button No. 2 and/or 3.
- 8 Raise - Must be used in combination with button No. 2 and/or 3.
- 9 Lower - Must be used in combination with button No. 2 and/or 3.
- 10 Stop - Interrupts an initiated function (5-7). Stop is also used to activate the standby function and when programming M1 and M2. Interrupts releasing of the front spring brake when this function is activated.

### Vehicles with A suspension

The control box for vehicles without front axle air suspension does not have button No. 2. For spare part purposes, use the control box for full air suspension vehicles.

### Standby

To allow for loading/unloading when the starter voltage is off, there is a built-in standby function. This function means that the vehicle continues its quick control and compensation for level changes for a maximum of 120 minutes after the starter voltage has been switched off.

The Standby level is not linked to any of the pre-programmed or calibrated levels.

### Activating Standby

Standby mode is activated by pressing the control box button No. 10 while switching the starter voltage off.

### Programming M1 and M2

The control box allows for two levels to be programmed in the control unit. These could e.g. be the height of two frequently visited loading docks.

Program according as follows:

- 1 Press button No. 2 and/or 3 (raise/lower front and/or rear).
- 2 Set the desired level using the control box.
- 3 Press the STOP button
- 4 Hold the STOP button and simultaneously depress M1 or M2.
- 5 Release both buttons.

The level programming is now completed and the level is stored in the memory.

To set one of the programmed levels:

- 1 Depress button No. 2 or 3 (raise or lower, front or rear).
- 2 Press M1 or M2.

### Level adjustment

When changing level using the control box, the control unit ensures that the level adjustment of the front and rear is as even as possible.

Level adjustment is thus requested using the control box. The control unit will calculate level points for the front and rear axles. These level points must be passed simultaneously during the level adjustment. If e.g. the front of the vehicle is being lowered or raised quicker than the rear, the front level adjustment will be interrupted until the rear has reached the same level.

This even level adjustment is useful e.g. when handling a demountable platform.

### Generation 2.1a

The function of the control box is not affected by the load transfer of generation 2.1A. I.e. the control box may be operated also during the load transfer phase. In addition, the load transfer may be activated when the control box is activated.

# Electrical system

## Control unit

### Input and output signals

For ELC generation 2 the same control unit is used for all vehicle types.

The control unit is controlled by a number of parameters. Depending on the parameter settings the control unit operates in different ways. To achieve correct vehicle behaviour, it is important that the programming is correct and describes the actual configuration of the vehicle. The control unit is programmed using Scania Programmer 2.

### Control unit connections

The control unit connections for input and output signals have the following functions.

Pin:

- 1 Supply voltage (30) to control unit.
- 2 Diagnostic cable L.
- 3 Input signal for function raise/lower tag axle from instrument panel switch. The cable is marked ELC3. On vehicles from early production, the cable may be marked ELC24.
- 4 Diagnostic cable K.
- 5 Not used.
- 6 Signal cable from pressure sensor in tag axle/rear rear axle suspension bellows.
- 7 Signal cable from pressure sensor in front rear axle suspension bellows.
- 8 Not used.
- 9 Supply voltage (15) from starter lock.
- 10 Not used.
- 11 Output signal to valve for function raise/lower front axle suspension bellows.

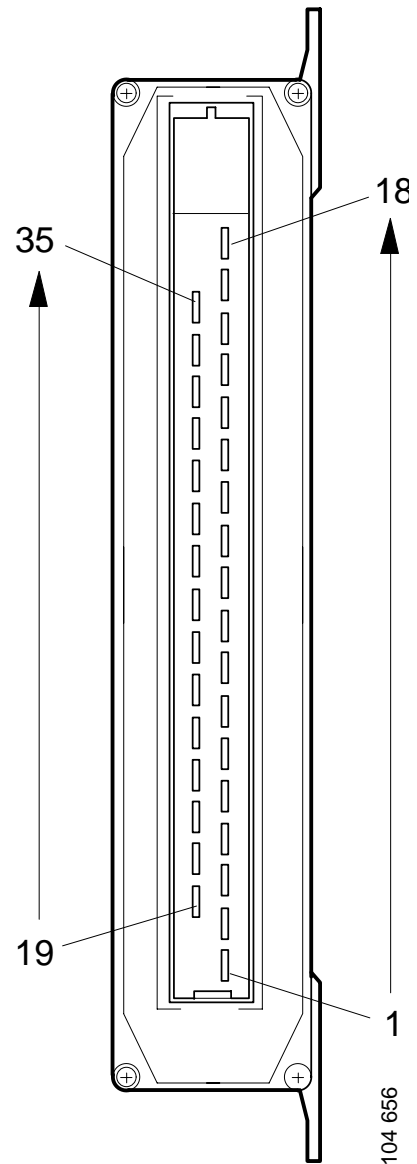

*Pin location on control unit.*

- |    |   |    |   |
|----|---|----|---|
| 12 | Output signal to valve for function raise/lower tag axle/rear rear axle suspension bellows.   | 30 | Not used.   |
| 13 | Output signal to valve for function raise/lower tag axle suspension bellows.  | 31 | Not used.   |
| 14 | Output signal to valve for function raise/lower tag axle.   | 32 | Not used.   |
| 15 | Output signal to control valve for function raise/lower suspension bellows.   | 33 | Output signal to warning lamp for system fault.   |
| 16 | Input signal from brake lamp relay.   | 34 | Output signal to warning lamp for level fault.  |
| 17 | Input signal for load transfer from instrument panel switch.  | 35 | Old configuration: Not used.<br><br>New configuration: Output signal to warning lamp for tag axle lift in the switch. (S105). |
| 18 | Output signal to warning lamp for load transfer.  |    |   |
| 19 | Input signal from switch for alternative (temporary) drive level.   |    |   |
| 20 | Timer signal from control box. The signal is activated when a button on the control box is depressed. The control unit needs the timer signal from pin 20 in order to decode the data signal on pin 21. |    |   |
| 21 | Data signal from control box. The control unit needs the timer signal from pin 20 in order to decode the data signal.   |    |   |
| 22 | Speed signal from tachograph.   |    |   |
| 23 | Not used.   |    |   |
| 24 | Input signal from bogie differential lock confirmation contact.   |    |   |
| 25 | Level sensor signal rear.   |    |   |
| 26 | Level sensor signal front.  |    |   |
| 27 | Earth (31).   |    |   |
| 28 | Not used.   |    |   |
| 29 | Output signal to valve for releasing front spring brakes.   |    |   |

## Replacement of control unit

Experience shows that control unit faults seldom occur. Consequently, fault codes and fuses shall be checked before the control unit is replaced.

When a control unit is replaced, the new control unit shall be programmed to conform to the vehicle configuration. The control unit is programmed using Scania Programmer 2.

When a control unit is replaced, fault codes may be generated since the control unit has not been calibrated for the level and pressure sensors.

## Calibration

The level and pressure sensors have individual differences after production. These differences are considered by the control unit in calibration.

Consequently, the control unit must be calibrated in order to function properly.

Calibration means that the value generated by the sensor at a specific level, or when there is no pressure in the bellows, is recorded in the control unit memory. In the control process, the control unit considers these values and compensates for tolerance differences.

For further details on calibration, refer to Work description.

## Generation 2.1A

As from generation 2.1A, calibration can also be performed by means of Scania Programmer 2.

At present, 2nd generation control units cannot be calibrated by means of PC. SP2 will be modified to include this function further on.

## Warning lamps

### System fault

If a fault that can be identified by the control unit occurs in the system, the control unit will warn the user by illuminating the system fault warning lamp.

At the same time, a fault code is generated and stored in the control unit memory. The fault code can be read out via Scania Diagnos 2 or as a flashing code. Refer to Troubleshooting for further information about this.

If the fault ceases, the warning lamp will in most cases go out automatically. However, the fault code will remain in the memory.

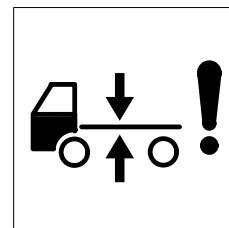

*System fault warning lamp*

## Level fault

When the vehicle is at a level which differs from the calibrated normal drive level, the level fault warning lamp illuminates.

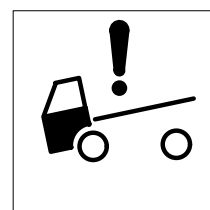

*Level fault warning lamp*

The normal drive level is the calibrated level at which the vehicle is normally driven.

A raised drive level accomplished by tag axle lift or load transfer as well as a temporary drive level requested by means of the temporary drive level switch may also be considered to be normal drive level. The level fault warning lamp will be on as long as the level change is in progress and then go out.

The normal drive level is set by means of the green button on the control box. For further information, refer to Control box.

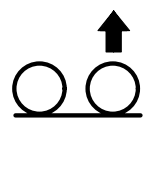

*Load transfer warning lamp*

## Load transfer

The load transfer warning lamp illuminates when load transfer is requested and is on as long as the bogie distribution does not conform to the specified value.

The lamp automatically goes out when load transfer is manually interrupted (or reduced) or when time limited load transfer is used.

**Old configuration:** The lamp integrated in the button also illuminates when tag axle lift or load transfer has been requested.

The lamp in the button goes out when load transfer is manually interrupted.

**New configuration:** The warning lamp in the button illuminates when the tag axle is up and goes out when the tag axle is down.

Thus, the lamp indicates that the tag axle is up.

**Generation 2.1A:** The load transfer lamp on the panel illuminates when the control unit has received and approved a request for load transfer. The lamp in the button illuminates when the control unit has approved a complete

load transfer with tag axle lift and goes out when the tag axle is lowered.

The lamp indicates that the control unit has approved the tag axle lift.

The lamp in the panel also is on when load transfer is gradually reduced and does not go out until the load transfer is completed.





# Valves and sensors

## Solenoid valve block

The generation 2 ELC uses a single or double solenoid valve block for suspension control, V54 or V54+V55. The the valve block operation differs depending on the vehicle configuration.

In production, Scania uses four different solenoid valve blocks. Only two types of block are available as spare parts: One double and one single.

Certain blocks used in production have limited functionality, whereas the spare blocks contain all functions. If a spare block is used for a vehicle with limited functionality, e.g. A suspension, those outputs that are not used should be plugged.

## Solenoid valve block V54

The single solenoid valve block V54 is used for the following vehicles:

Wheel configuration	Load transfer	Solenoid valves
4x2A	-	2
4x2B	-	3
6x4A	Without	2
6x4B	Without	3
6x4A	With	3
8x4A	Without	2
8x4B	Without	3
8x4A	With	3

## Solenoid valve block V54

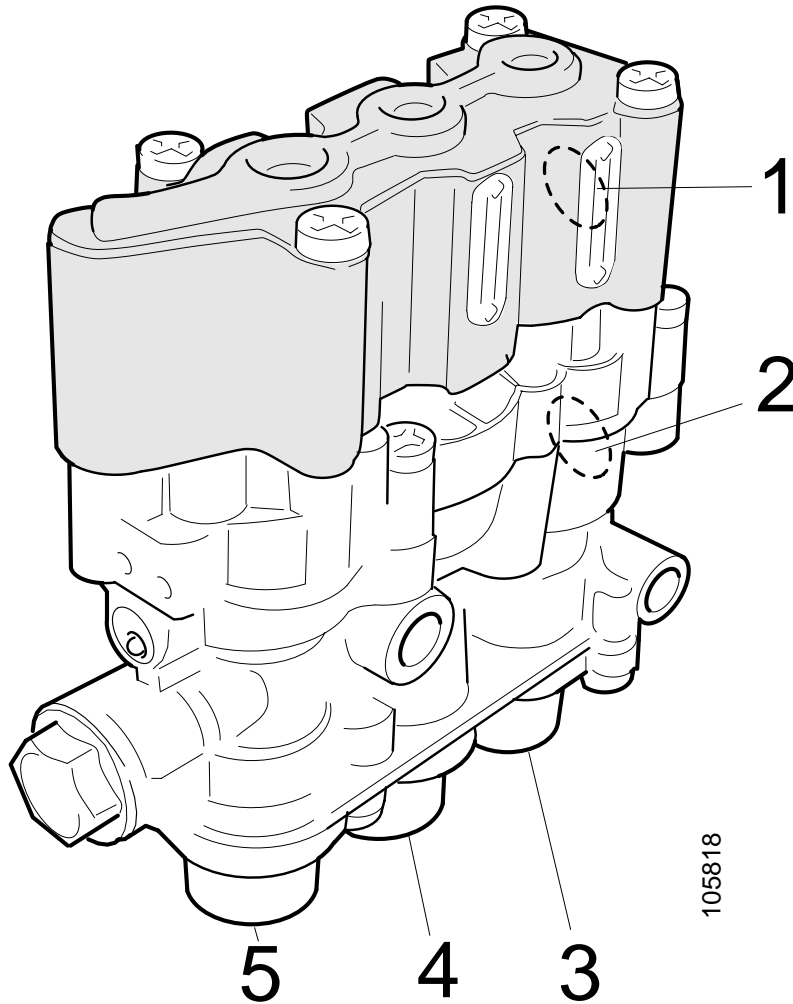

105818

- 1 *Electrical connection*
- 2 (3) *Outlet*
- 3 (11/25) *Feed*
- 4 (22) *Control air for rear suspension bellows*
- 5 (23) **Vehicles with B suspension:** *Control air for front suspension bellows* **Vehicles with A suspension and load transfer:** *Control air for rear rear axle suspension bellows*

## Solenoid valve block V54+V55

The double solenoid valve block V54+V55 is used for all vehicles where the functionality of the single block is not sufficient.

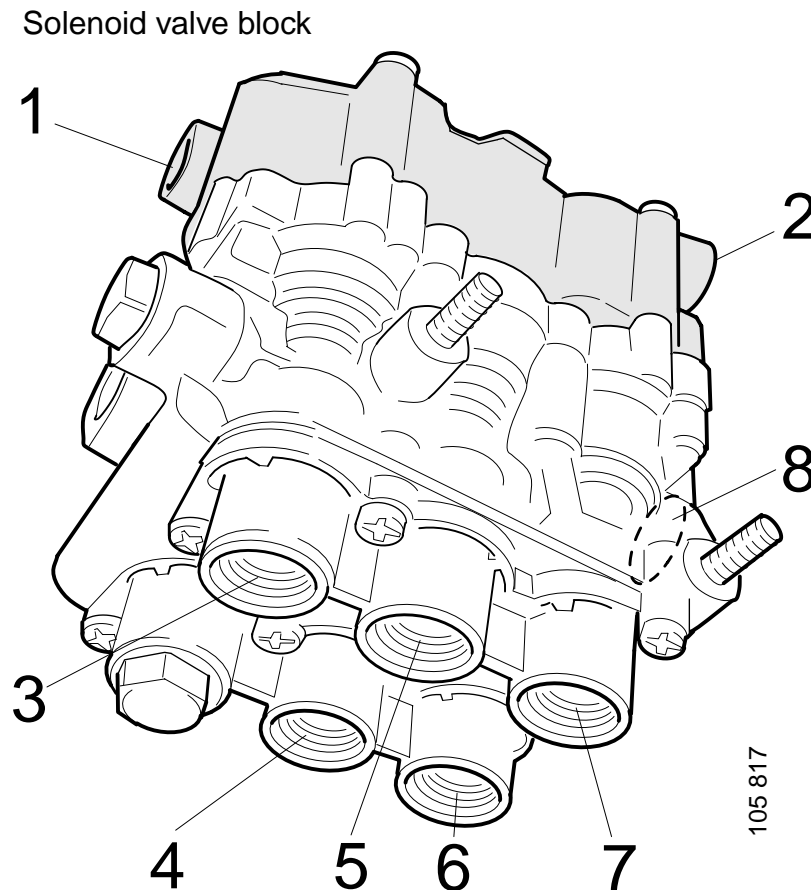

- 1 *Electrical connection V55*
- 2 *Electrical connection V54*
- 3 *(V54-23) Control air, outlet (see table V54)*
- 4 *(V55-22) Control air, outlet (see table V55)*
- 5 *(V54-22) Control air, outlet (see table V54)*
- 6 *(V55-23) Control air, outlet (see table V55)*
- 7 *(V54-11) Air feed, intake*
- 8 *(V54-3) Outlet*

## Intakes and outlets on V54+V55

**Table V54**

	V54-3	V54-11	V54-22	V54-23
Air feed	All			
Outlet (venting)	All			
Control air for suspension bellows on rear axle and front tag axle				8x2/4A, 8x2/4B
Control air for suspension bellows on rear axle				All except those above
Control air for front suspension bellows				All - Except for 6x4B and 8x4B with load transfer

**Table V55**

	V55-22	V55-23
Control air for front suspension bellows	6x4B and 8x4B with load transfer	
Control air for tag axle lifting bellows	All except those above	
Control air for suspension bellows on tag axle/rear rear axle	All	

## Solenoid valve

### Solenoid valve V32

The V32 solenoid valve releases the parking brake during load handling. It is activated when vehicle raising or lowering has been requested, in order to prevent bending stresses in the chassis.

For more information see Brake system

## Sensors

### Level sensors T72 and T73

With the transition to generation 2 ELC, new, tighter connectors were introduced for all electrical connections. These are bayonet-type connectors in accordance with DIN.

The chassis height is measured by inductive sensors. The level sensors are located on the frame, and measure the distance between frame and axle.

The level sensors consist of a fixed coil and a moving core. If the vehicle is raised or lowered the core will be either pushed into the coil or pulled out of it.

The inductance of the coil varies depending on how much of the core is inside the coil.

The control unit sends a pulse to the sensor. The pulse duration varies with the inductance of the coil.

By measuring the pulse duration, a value corresponding to the height of the vehicle is obtained.

Level sensor

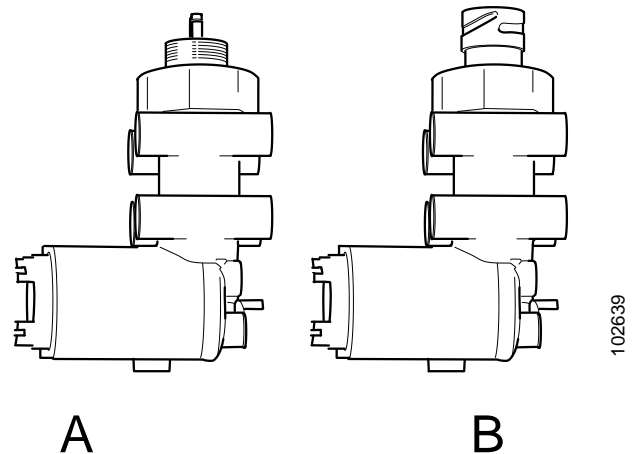

*A Earlier design*

*B Generation 2 with DIN connector*

Level sensor

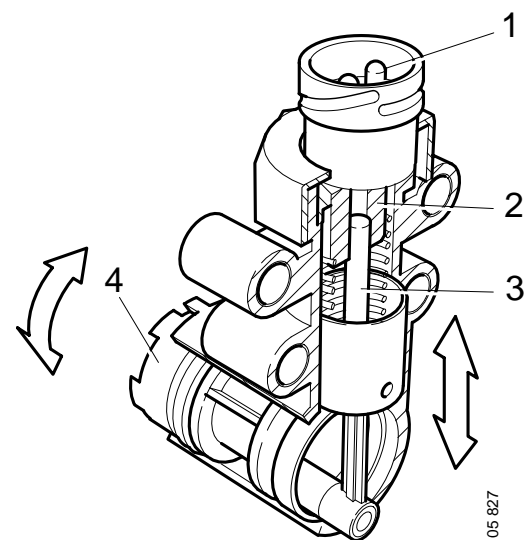

*1 Connector*

*2 Coil*

*3 Core*

*4 Lever retainer*

## Example:

- The vehicle is raised. The core moves into the coil. The inductance and the pulse duration increase.
- The vehicle is lowered. The core moves out of the coil. The inductance and the pulse duration decrease.

Since the core and the coil do not contact each other, there is no wear between these two parts. The output of the sensor is thus very accurate. In trouble shooting, no resistance variation can be measured when the sensor is influenced. The sensor coil resistance constantly 120 ohm, regardless of the position of the core.

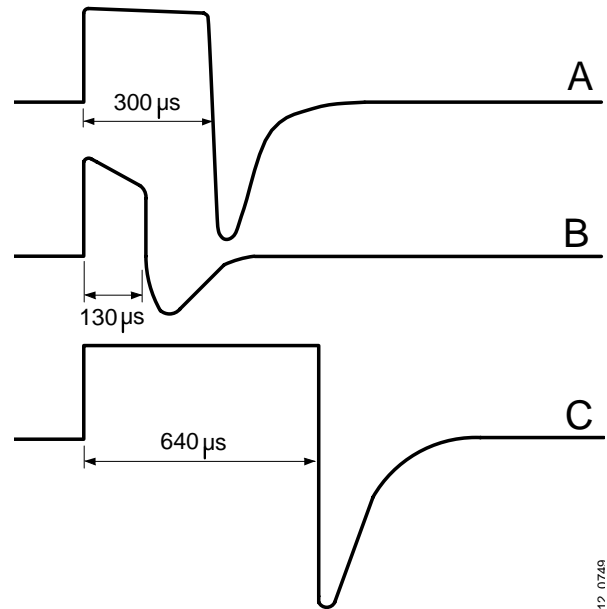

*A Pulse at drive level.*

*B Pulse at low inductance (vehicle level low).*

*B Pulse at high inductance (vehicle level high).*

*The values are approximate.*

## Pressure sensor T70 and T71

On vehicles with load transfer, the pressure in the rear axle suspension bellows is controlled using data from two pressure sensors. The sensors are located on the left hand suspension bellows on the rear axle and the rear rear axle/tag axle.

The pressure sensor is connected via three cables. One earth cable, one feed cable and one signal cable to the control unit.

The pressure acts on a silicon diaphragm which in turn acts on a Wheatstone bridge and an electronic measuring amplifier. The measuring amplifier generates a signal which varies between 0.5 and 4.5 V in proportion to the pressure in the bellows. A voltage of 0,5 V corresponds to atmospheric pressure (ambient air pressure, bellows pressure is 0 bar) and 4,5 V corresponds to a bellows pressure of 10 bar. The feed voltage is the battery voltage, + 24 V.

In the bayonet connection of the pressure sensor there is a hole which allows atmospheric pressure to enter the sensor. This hole must not be blocked, as the sensor uses the atmospheric pressure as a pressure reference. The air that the sensor requires for this is passed to the sensor through the wiring.

Pressure sensor

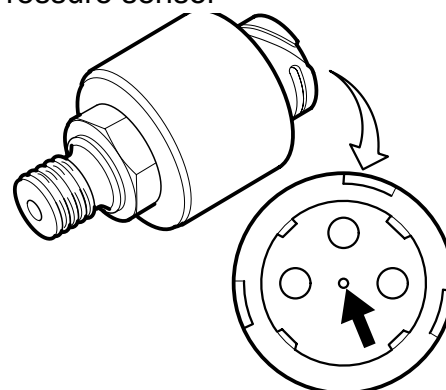

*The hole in the pressure sensor's electrical connection must not be blocked.*