



16:04-00

Edition 1

Bakgrundsbelysning i hytt

Background lighting in cab

Allgemeine Fahrerhausbeleuchtung

Achtergrondverlichting in cabine

Eclairage de fond dans cabine

Alumbrado de fondo en cabina

Luce de sottofondo

Ohjaamon Taustavaaistus

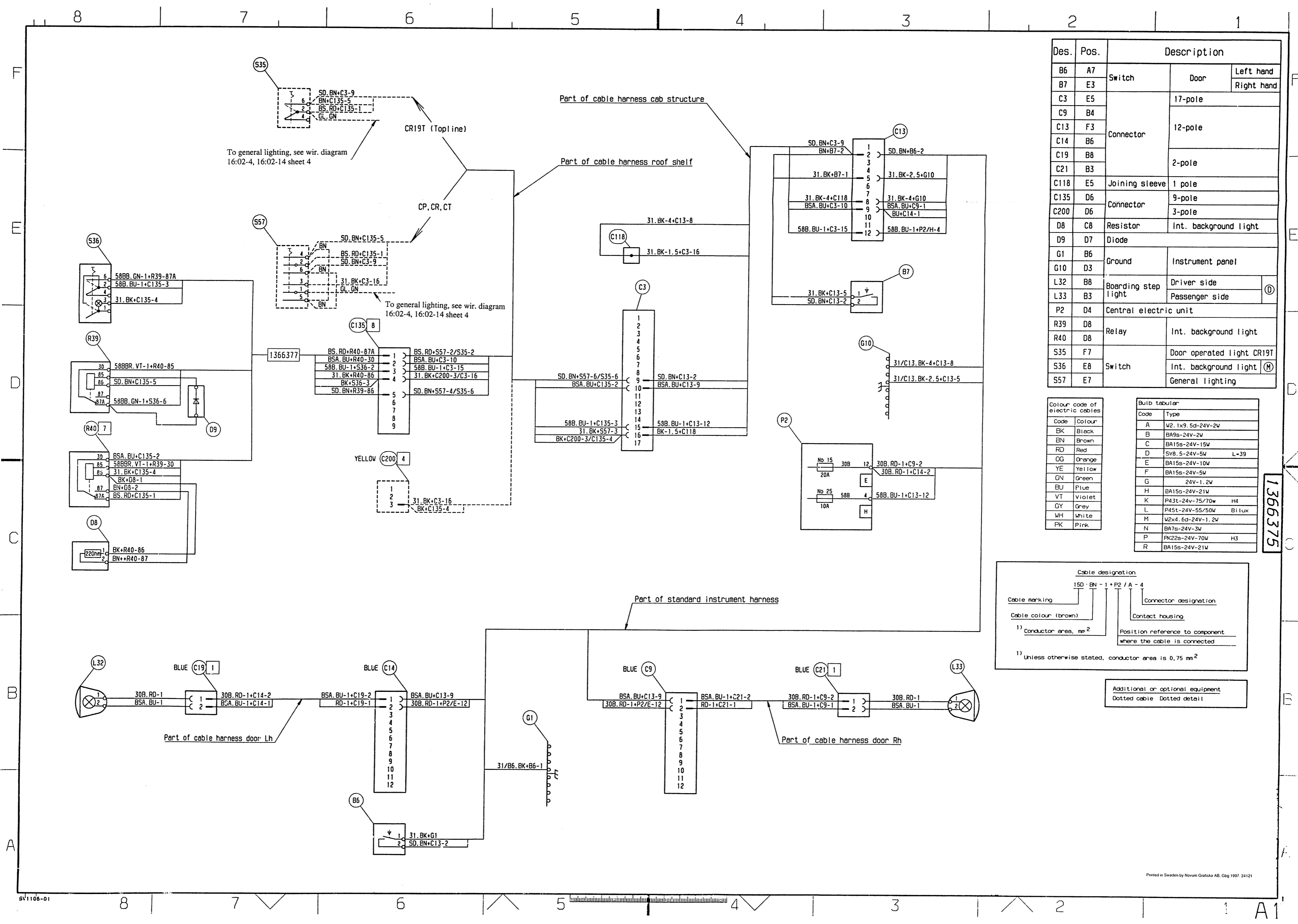

Des.	Pos.	Description	
B6	A7	Switch	Door Left hand
B7	E3	Switch	Door Right hand
C3	E5	Connector	17-pole
C9	B4		12-pole
C13	F3		2-pole
C14	B6		2-pole
C19	B8	Joining sleeve	1 pole
C21	B3		9-pole
C118	E5	Connector	3-pole
C135	D6		3-pole
C200	D6	Resistor	Int. background light
D8	C8	Diode	
D9	D7	Diode	
G10	B6	Ground	Instrument panel
G10	D3	Ground	
L32	B8	Boarding step light	Driver side
L33	B3		Passenger side
P2	D4	Central electric unit	
R39	D8	Relay	Int. background light
R40	D8	Relay	Int. background light
S35	F7	Switch	Door operated light CR19T
S36	E8	Switch	Int. background light (M)
S57	E7	Switch	General lighting

Colour code of electric cables	
Code	Colour
BK	Black
BN	Brown
RD	Red
OG	Orange
YE	Yellow
GN	Green
BU	Blue
VT	Violet
GY	Grey
WH	White
PK	Pink

Build tabular	
Code	Type
A	W2, 1x9, 5d-24V-2W
B	BA9s-24V-2W
C	BA15s-24V-15W
D	5V8, 5-24V-5W L-39
E	BA15s-24V-10W
F	BA15s-24V-5W
G	24V-1, 2W
H	BA15s-24V-21W
K	PA3t-24V-75/70W H4
L	PA4t-24V-55/50W BiLux
M	W2x4, 6d-24V-1, 2W
N	BA7s-24V-3W
P	PK22s-24V-70W H3
R	BA15s-24V-21W

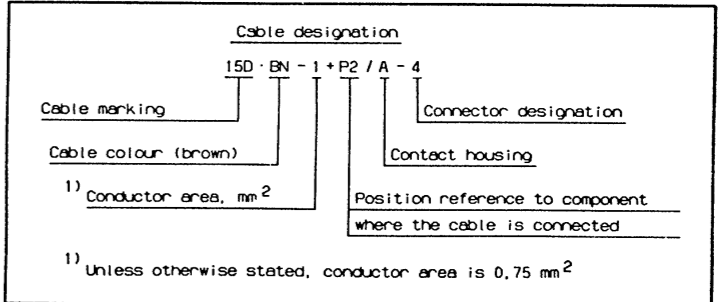

Additional or optional equipment
Dotted cable Dotted detail