



**16:04-03**

Edition 1

**Varningslampa för fällbart insteg**

**Warning lamp for folding boarding step**

**Warnlampe für klappbare Trittleche**

**Waarschuwingslampje voor inklapbare instaptreden**

**Témoin d'alerte, marche-pied rabattable**

**Lámpara de advertencia para escalón escamoteable**

**Luz de aviso para estribo retrátil**

**Spia per gradino retrattile**

**Käännettävän astimen varoitusvalo**

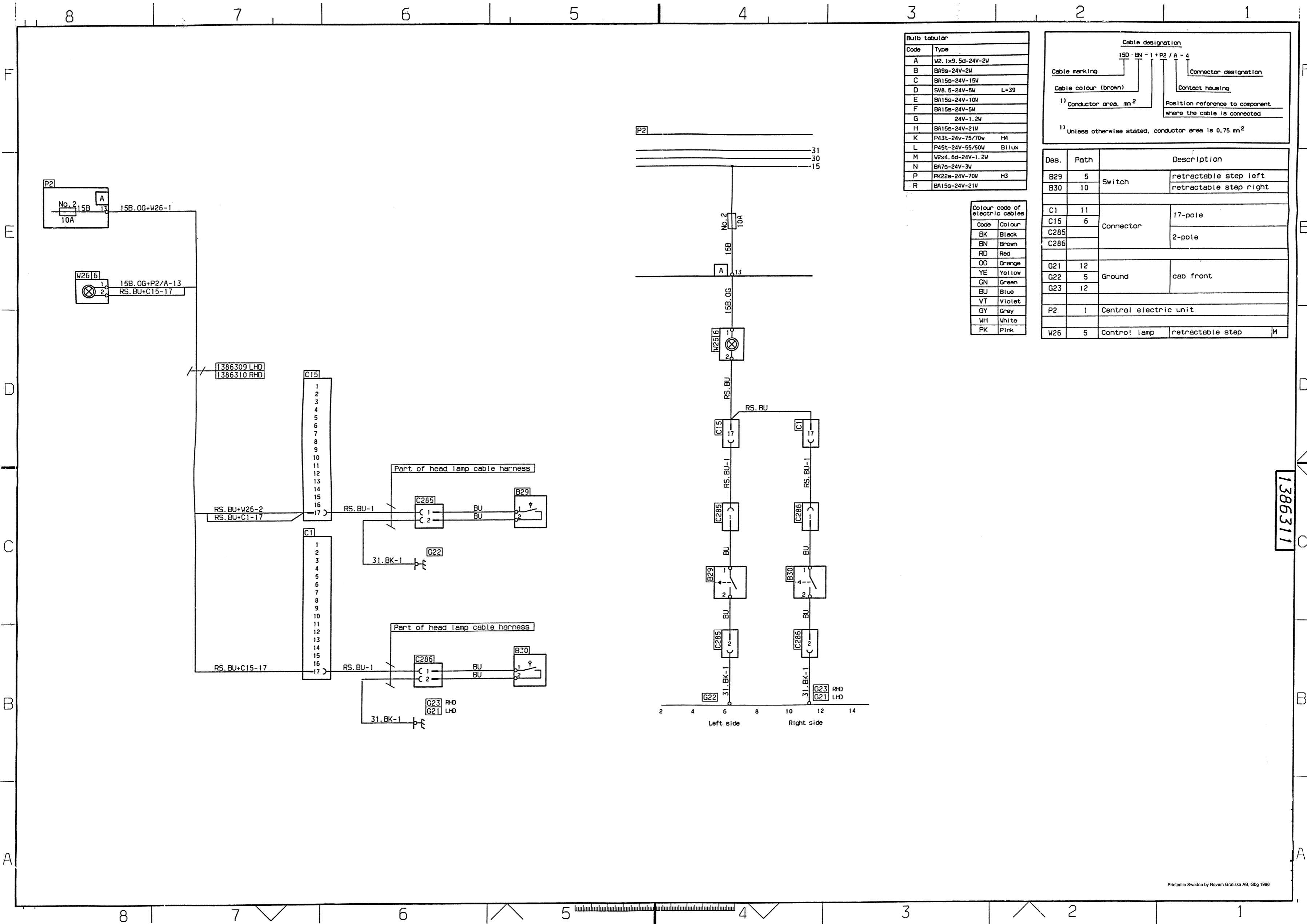

**Build tabular**

Code	Type
A	W2.1x9.5d-24V-2W
B	BA9s-24V-2W
C	BA15s-24V-15W
D	SV8.5-24V-5W L=39
E	BA15s-24V-10W
F	BA15s-24V-5W
G	24V-1.2W
H	BA15s-24V-21W
K	P43t-24V-75/70w H4
L	P45t-24V-55/50W Bliux
M	W2x4.6d-24V-1.2W
N	BA7s-24V-3W
P	PK22s-24V-70W H3
R	BA15s-24V-21W

**Colour code of electric cables**

Code	Colour
BK	Black
BN	Brown
RD	Red
OG	Orange
YE	Yellow
GN	Green
BU	Blue
VT	Violet
GY	Grey
WH	White
PK	Pink

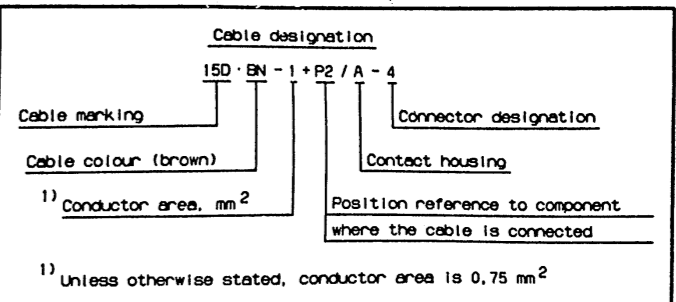

Des.	Path	Description
B29	5	Switch retractable step left
B30	10	Switch retractable step right
C1	11	Connector 17-pole
C15	6	
C285		
C286		
G21	12	Ground cab front
G22	5	
G23	12	
P2	1	Central electric unit
W26	5	Control lamp retractable step M

1386311