

16:04-23

Edition 2

Växellåda GRS890/900

Gearbox, GRS890/900

Getriebe GRS890/900

Versnellingsbak GRS890/900

Boîte de vitesses GRS890/900

Caja de cambios GRS890/900

Caixa de mudanças (velocidades), GRS890/900

Cambio GRS890/900

Vaihteisto GRS890/900

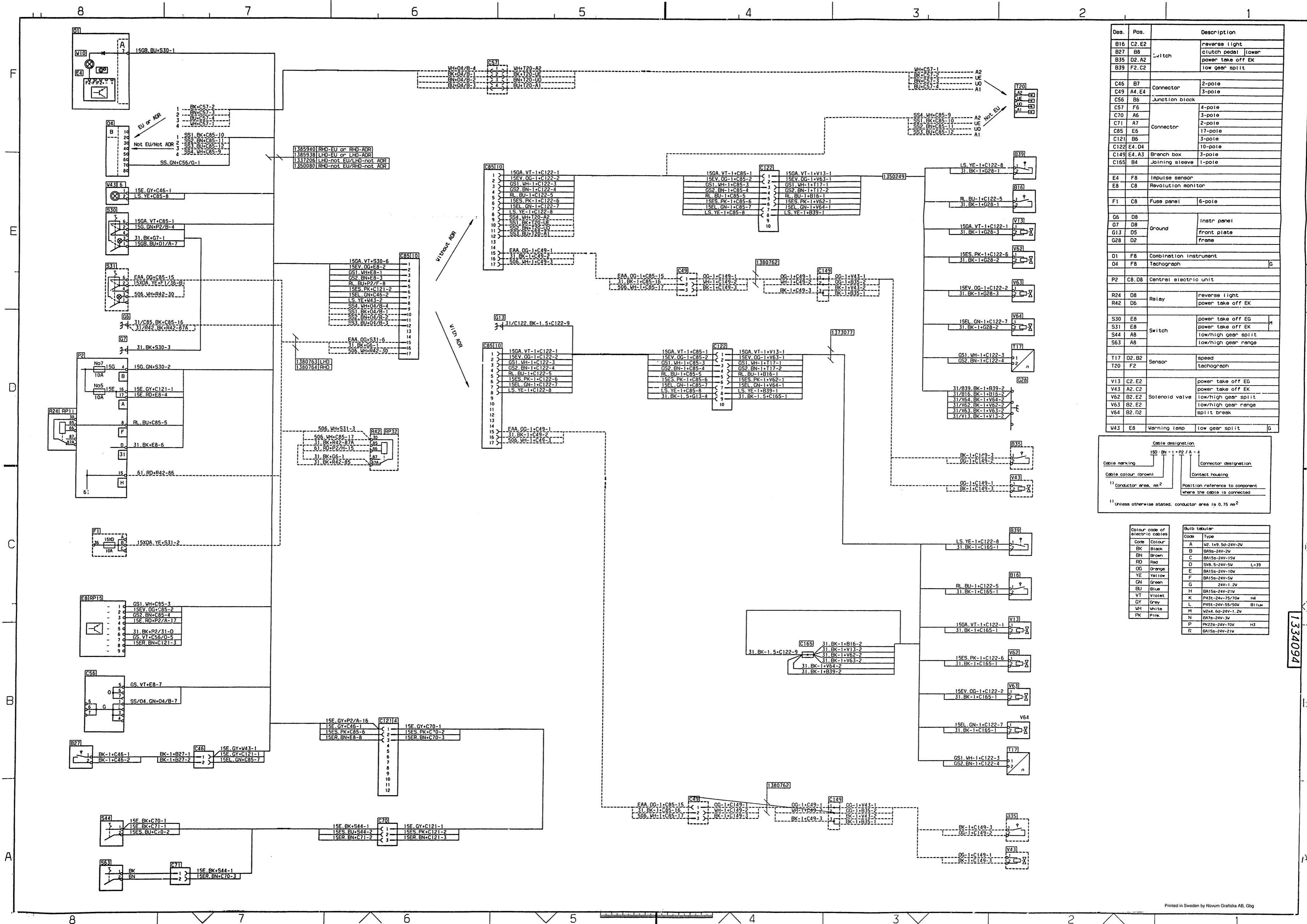

Des.	Pos.	Description
B16	C2, E2	reverse light
B27	B8	clutch pedal lower
B35	D2, A2	power take off EK
B39	F2, C2	low gear split
C46	B7	Connector 2-pole
C49	A4, E4	Connector 3-pole
C56	B8	Junction block
C57	F6	4-pole
C70	A6	3-pole
C71	A7	2-pole
C85	E6	Connector 17-pole
C121	B6	3-pole
C122	E4, D4	10-pole
C149	E4, A3	Branch box 3-pole
C165	B4	Joining sleeve 1-pole
E4	F8	Impulse sensor
E8	C8	Revolution monitor
F1	C8	Fuse panel 6-pole
G6	D8	Instr panel
G7	D8	Ground
G13	D5	front plate
G28	D2	frame
D1	F8	Combination instrument
D4	F8	Technograph
P2	C8, D8	Central electric unit
R24	D8	reverse light
R42	D6	Relay power take off EK
S30	E8	power take off EG
S31	E8	power take off EK
S44	A8	low/high gear split
S63	A8	low/high gear range
T17	D2, B2	speed
T20	F2	tachograph
V13	C2, E2	power take off EG
V43	A2, E2	power take off EK
V62	B2, E2	low/high gear split
V63	B2, E2	low/high gear range
V64	B2, D2	split break
W43	E8	Warning lamp low gear split

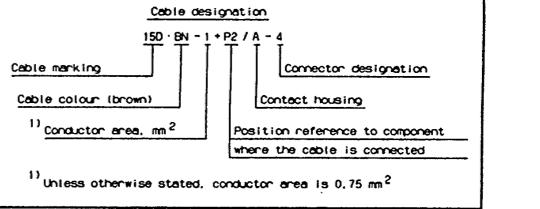

Code	Colour	Code	Type
BK	Black	A	12 1x3 5d-24V-2V
BN	Brown	B	30x3-24V-2V
RD	Red	C	30x3-24V-15V
OG	Orange	D	5x8 5-24V-5V L-39
YE	Yellow	E	30x3-24V-10V
GN	Green	F	30x3-24V-5V
BU	Blue	G	24V-12V
VT	Violet	H	30x3-24V-21V
GY	Grey	K	30x3-24V-75/70V H3
WH	White	L	30x3-24V-55/50V B11xk
PK	Pink	M	30x3-24V-12V
		N	30x3-24V-3U
		P	30x3-24V-70V H3
		R	30x3-24V-21V

1334094