

**16:04-26**

Edition 1

**Växellåda GRS890**

**Gearbox GRS890**

**Getriebe GRS890**

**Versnellingsbak GRS890**

**Boîte de vitesses GRS890**

**Caja de cambios GRS890**

**Cambio GRS890**

**Vaihteisto GRS890**

**4x4, 6x6**

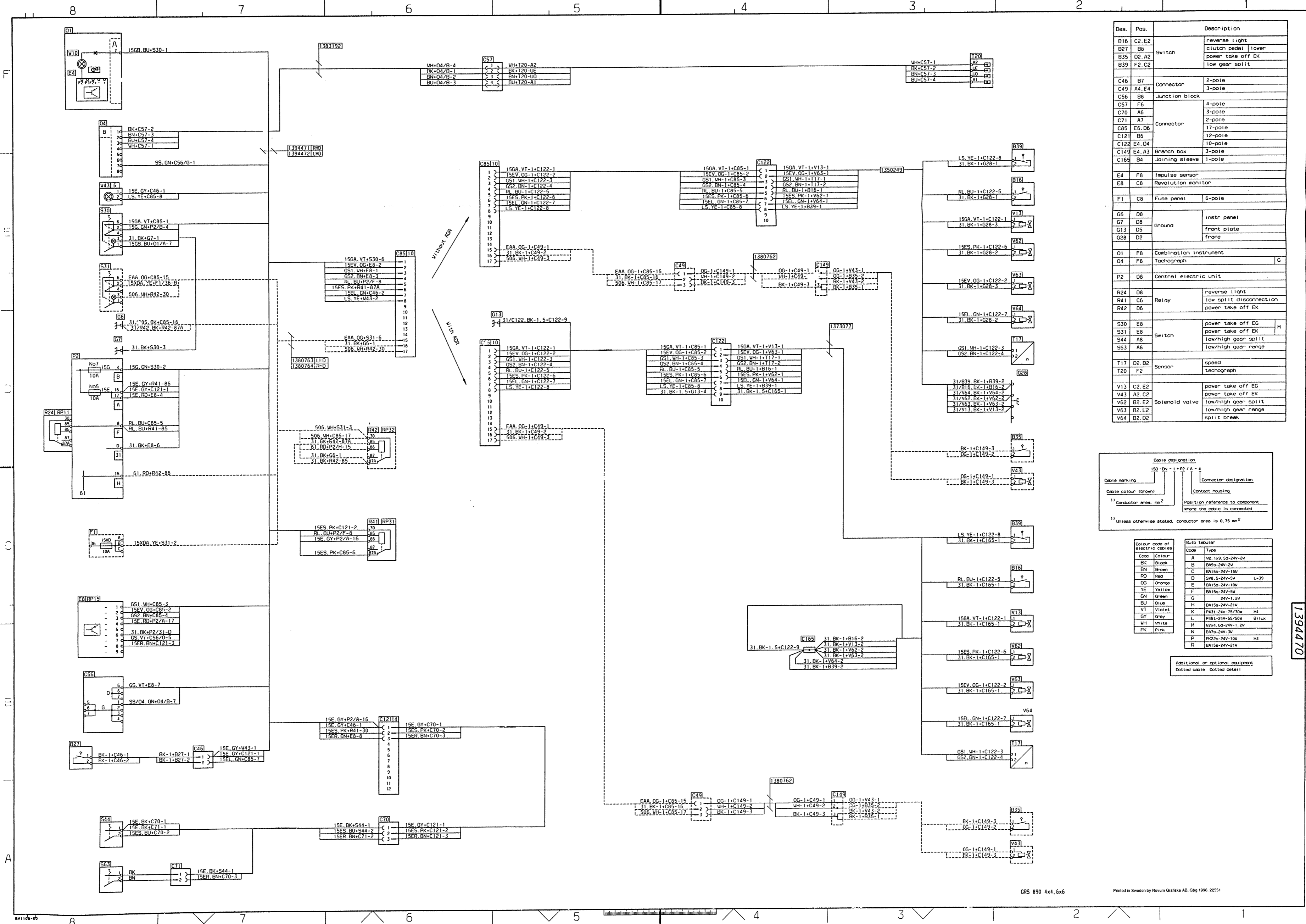

Des.	Pos.	Description
B16	C2, E2	reverse light
B27	B8	clutch pedal lower
B35	D2, A2	power take off EK
B39	F2, C2	low gear split
C46	B7	2-pole
C49	A4, E4	3-pole
C56	B8	Junction block
C57	F6	4-pole
C70	A6	3-pole
C71	A7	2-pole
C85	E6, D6	17-pole
C121	B4	12-pole
C122	E4, D4	10-pole
C149	E4, A3	3-pole
C165	B4	Joining sleeve
E4	F8	Impulse sensor
E8	C8	Revolution monitor
F1	C8	Fuse panel
G5	D8	Instr. panel
G7	D8	Ground
G13	D5	front plate
G28	D2	frame
O1	F8	Combination instrument
O4	F8	Tachograph
P2	D8	Central electric unit
R24	D8	reverse light
R41	C6	low split disconnection
R42	D6	power take off EK
S30	E8	power take off EG
S31	E8	power take off EK
S44	A8	low/high gear split
S63	A8	low/high gear range
T17	D2, B2	speed
V13	C2, E2	power take off EG
V43	A2, C2	power take off EK
V62	B2, E2	low/high gear split
V63	B2, L2	low/high gear range
V64	B2, D2	split break

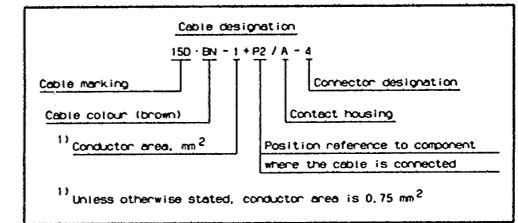

Code	Colour	Code	Type
A	Black	L	1x2, 1x3, 5x24V-2V
BK	Black	B	BA9s-24V-2V
BN	Brown	C	BA15s-24V-15V
RD	Red	D	5x8, 5-24V-5V L-39
OG	Orange	E	BA15s-24V-10V
YE	Yellow	F	BA15s-24V-5V
GN	Green	G	24V-1, 2V
BU	Blue	H	BA15s-24V-21V
VT	Violet	K	PA3L-24V-75/70W H4
GY	Grey	L	PA1L-24V-55/50W B11UK
WH	White	M	W4, 6x-24V-1, 2V
N	White	N	BA7s-24V-3V
PK	Pink	P	PA2s-24V-70W H3
		R	BA15s-24V-21V

Additional or optional equipment  
Dotted cable Dotted data!