

16:04-34

Edition 1

Retarder med automatisk avgasbroms (EEB)

Retarder with automatic exhaust brake (EEB)

**Retarder mit automatischer Abgasbremse
(EEB)**

Retarder met autom. uitlaatrem (EEB)

**Ralentisseur avec ralentisseur sur échappe-
ment automatique (EEB)**

**Ralentizador con freno de escape automático
(EEB)**

**Retardador com freio motor (travão de escape)
automático (EEB)**

**Rallentatore con freno motore automatico
(EEB)**

Hidastin ja aut. pakokaasujarru (EEB)

**Retarder z automatycznym hamulcem wyde-
chowym (EEB)**

Das.	Pos.	Description
C56	E4	Junction block
C98	D7	3-pole
C192	B6	17-pole
C193	C3	Connector
C194	B3	2-pole
C196	B3	3-pole
C197	B3	
D15	F7	Diode control lamp
D18	C6	Diode unit
D37	D8	Potentiometer brake pedal
E1	C8	exhaust brake, white sm. lin
E5	D8	Control unit Opticruise
E39	C8	Retarder
G5	E6	Instr. panel
G7	D6	Ground
G13	B6	front plate
L106	F6	Symbol lighting/retarder panel
O1	E8	Combination instrument
P2	F8	Central electric unit
S17	D6	aut exhaust brake on/off retarder
S43	F6	Switch
S91	E6	ret. brake pedal on/off
S96	E8	diagnostics retarder
T63	C2	coolant temp. 1 retarder
T64	B2	coolant temp. 2 retarder
V74	A3	retarder on/off
V75	A3	accumulator
V76	A3	proportional
V25	E8	retarder
V55	E6	retarder in operation

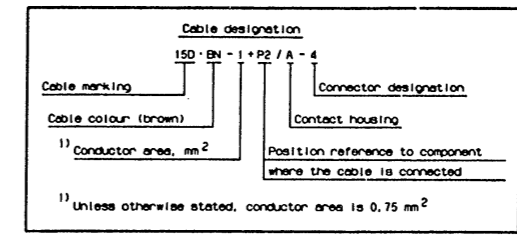

Additional or optional equipment

Dotted cable Dotted detail

Code	Type
A	W2, 1x5, 5d-24V-2V
B	BA15s-24V-2V
C	BA15s-24V-15W
D	BV8, 5-24V-5W L-39
E	BA15s-24V-10W
F	BA15s-24V-5W
G	24V-1, 2V
H	BA15s-24V-21W
K	P43L-24V-75/70w H4
L	PA3L-24V-55/50w B1Lux
M	W54L-6d-24V-1, 2V
N	BA7s-24V-3W
P	PK29s-24V-70W H3
R	BA15s-24V-21W

Colour code of electric cables

Code	Colour
BK	Black
BN	Brown
RD	Red
OG	Orange
YE	Yellow
GN	Green
BU	Blue
VT	Violet
GY	Grey
WH	White
PK	Pink

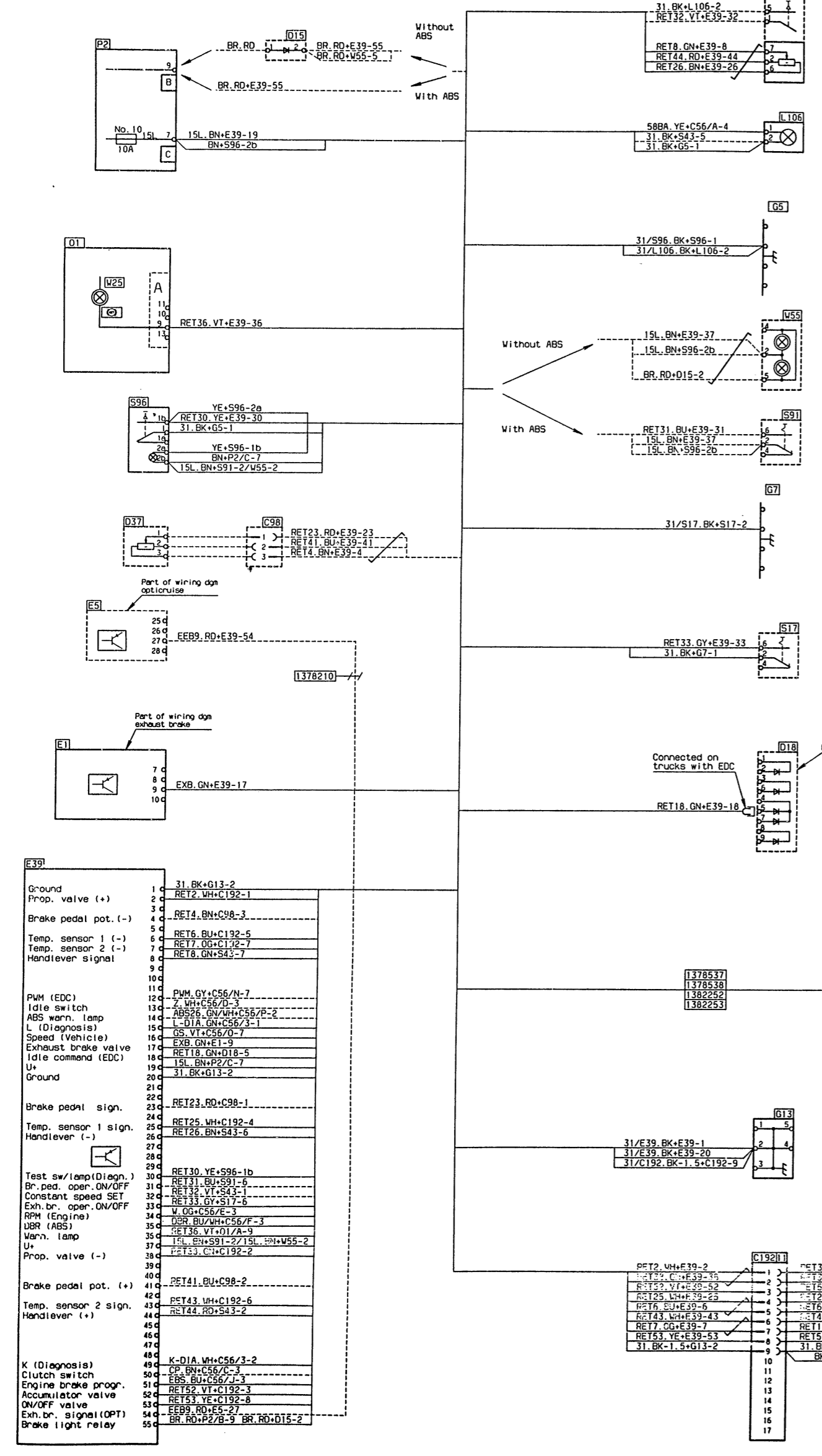
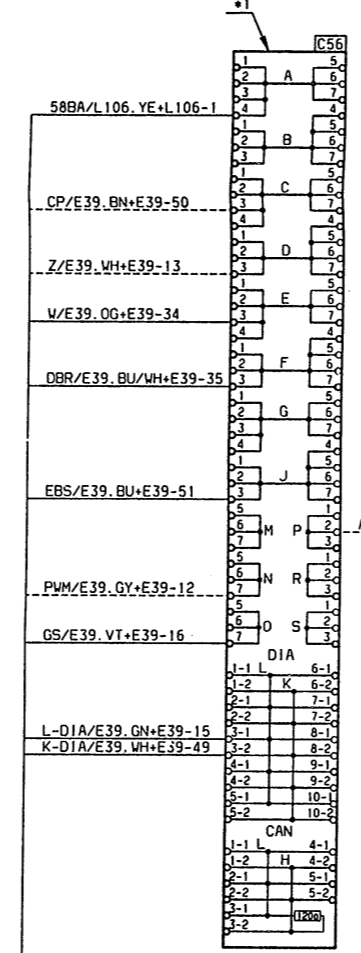
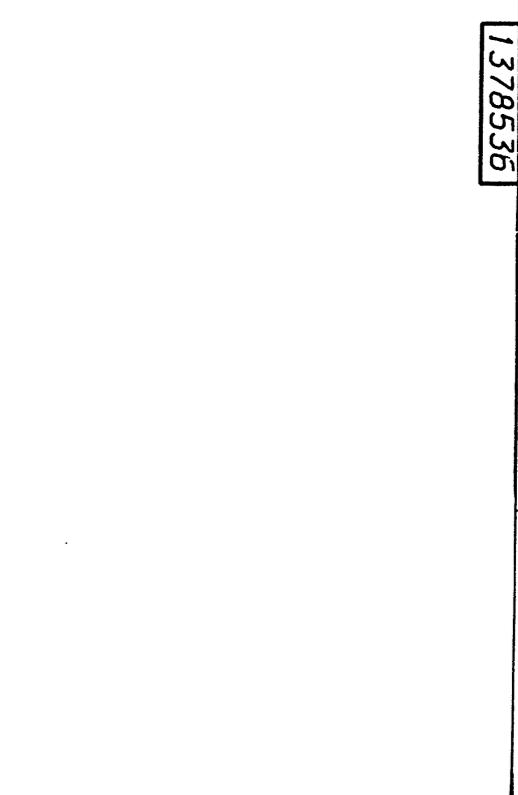

E39

1	31 BK+G13-2
2	RET2, WH+C192-1
3	RET4, BN+C98-3
4	RET6, BU+C192-5
5	RET7, OG+C192-7
6	RET8, GN+S43-7
7	RET10, YE+E39-30
8	RET11, BU+E39-31
9	RET12, WH+C192-1
10	RET13, RD+E39-23
11	RET14, BU+E39-24
12	RET15, GN+S43-7
13	RET16, BU+C192-5
14	RET17, OG+C192-7
15	RET18, GN+D18-5
16	RET19, GN+S43-7
17	RET20, BN+S43-5
18	RET21, BU+C98-2
19	RET22, WH+C192-4
20	RET23, RD+C98-1
21	RET24, BU+C98-2
22	RET25, WH+C192-4
23	RET26, BN+S43-5
24	RET27, GN+S43-7
25	RET28, GN+S43-7
26	RET29, GN+S43-7
27	RET30, YE+S96-1b
28	RET31, BU+E39-31
29	RET32, WH+C192-4
30	RET33, GY+E39-12
31	RET34, BU+E39-31
32	RET35, GN+S43-7
33	RET36, BU+C192-5
34	RET37, OG+C192-7
35	RET38, GN+S43-7
36	RET39, GN+S43-7
37	RET40, GN+S43-7
38	RET41, BU+C98-2
39	RET42, WH+C192-4
40	RET43, BU+C98-2
41	RET44, BU+C98-2
42	RET45, WH+C192-4
43	RET46, BU+C98-2
44	RET47, GN+S43-7
45	RET48, GN+S43-7
46	RET49, GN+S43-7
47	RET50, GN+S43-7
48	RET51, GN+S43-7
49	RET52, WH+C192-4
50	RET53, WH+C192-4
51	RET54, WH+C192-4
52	RET55, WH+C192-4
53	RET56, WH+C192-4
54	RET57, WH+C192-4
55	RET58, WH+C192-4