

16:04-42

Edition 1

Luftfjädring - elektroniskt styrd (ELC)
4x2 samt 6x4 utan lastöverföring

Air suspension, electronically controlled (ELC)
4x2 and 6x4 without load transfer

Luftfederung - elektronisch gesteuert (ELC)
4x2 und 6x4 ohne Lastübertragung

Luchtvering - elektronisch gestuurd (ELC)
4x2 en 6x4 zonder lastoverheveling

Suspension - commande électronique (ELC)
4x2 et 6x4 sans report de charge

Suspensión neumática - mando electrónico (ELC)
4x2 y 6x4 sin transferencia de la carga

Suspensão pneumática controlada eletronicamente (ELC)
4x2 e 6x2 sem transferência de carga

Sospensione pneumatica a comando elettronico (ELC)
4x2 e 6x4 senza trasferimento del carico

Ilmajousitus - elektronisesti ohjattu (ELC)
4x2 sekä 6x4 ilman painonsiirtoa

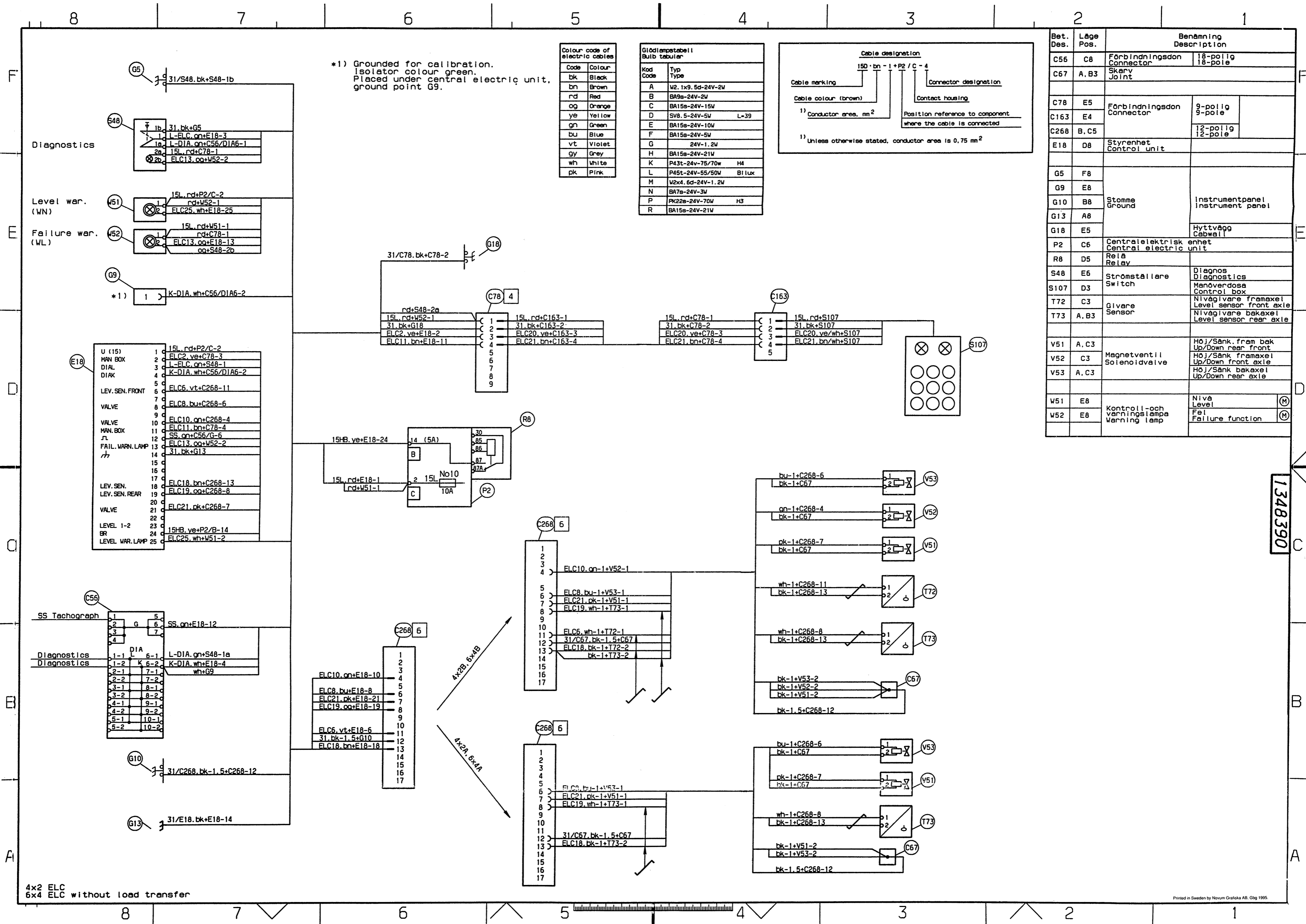

Colour code of electric cables

Code	Colour
bk	Black
bn	Brown
rd	Red
og	Orange
ys	Yellow
gn	Green
bu	Blue
vt	Violet
gy	Grey
wh	White
pk	Pink

Glödlampstabell
Bulb tabular

Kod	Typ
A	W2. 1x9. 5g-24V-2W
B	BA9s-24V-2W
C	BA15s-24V-15W
D	SV8. 5-24V-5W L=39
E	BA15s-24V-10W
F	BA15s-24V-5W
G	24V-1.2W
H	BA15s-24V-21W
K	P43t-24v-75/70w H4
L	P45t-24V-55/50W BILux
M	V2x4. 6d-24V-1.2W
N	BA7s-24V-3W
P	PK22s-24V-70W H3
R	BA15s-24V-21W

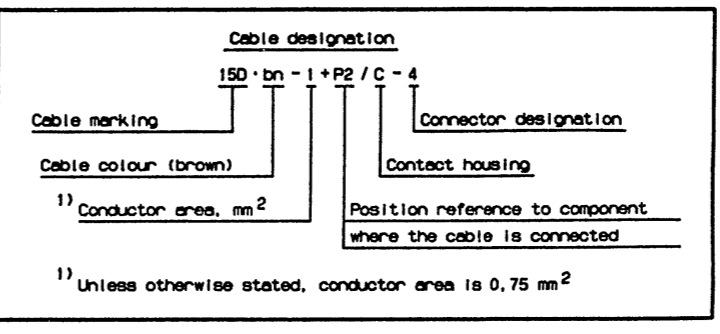

Bet. Des.	Läge Pos.	Benämning Description	
C56	C8	Förbindningsdon Connector	18-polig 18-pole
C67	A, B3	Skerv Joint	
C78	E5	Förbindningsdon Connector	9-polig 9-pole
C163	E4		12-polig 12-pole
C268	B, C5		
E18	D8	Styrenhet Control unit	
G5	F8		
G9	E8		
G10	B8	Stomme Ground	Instrumentpanel Instrument panel
G13	A8		
G18	E5		Hyttvägg Cabwall
P2	C6	Centralelektrisk enhet Central electric unit	
R8	D5	Relä Relay	
S48	E6	Strömställare Switch	Diagnos Diagnostics
S107	D3		Manöverdosan Control box
T72	C3	givare Sensor	Nivågivare framaxel Level sensor front axle
T73	A, B3		Nivågivare bakaxel Level sensor rear axle
V51	A, C3	Magnetventil Solenoidvalve	Höj/Sänk fram bak Up/Down rear front
V52	C3		Höj/Sänk framaxel Up/Down front axle
V53	A, C3		Höj/Sänk bakaxel Up/Down rear axle
W51	E8	Kontroll- och varningslampa Warning lamp	Nivå Level
W52	E8		Fel Failure function

4x2 ELC
6x4 ELC without load transfer

cardiagn.com

1348390