

16:04-43

Edition 1

Luftfjädring - elektroniskt styrd (ELC) 6x2

Air suspension, electronically controlled (ELC) 6x2

Luftfederung - elektronisch gesteuert (ELC) 6x2

Luchtvering - elektronisch gestuurd (ELC), 6x2

Suspension - commande électronique (ELC) 6x2

Suspensión neumática - mando electrónico (ELC) 6x2

Suspensão pneumática controlada eletronicamente (ELC) 6x2

Sospensione pneumatica a comando elettronico (ELC) 6x2

Ilmajousitus - elektronisesti ohjattu (ELC) 6x2

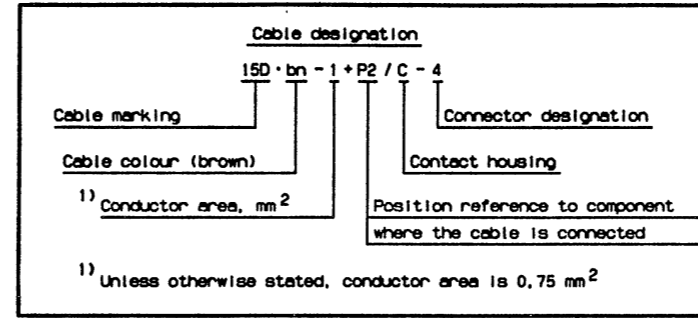
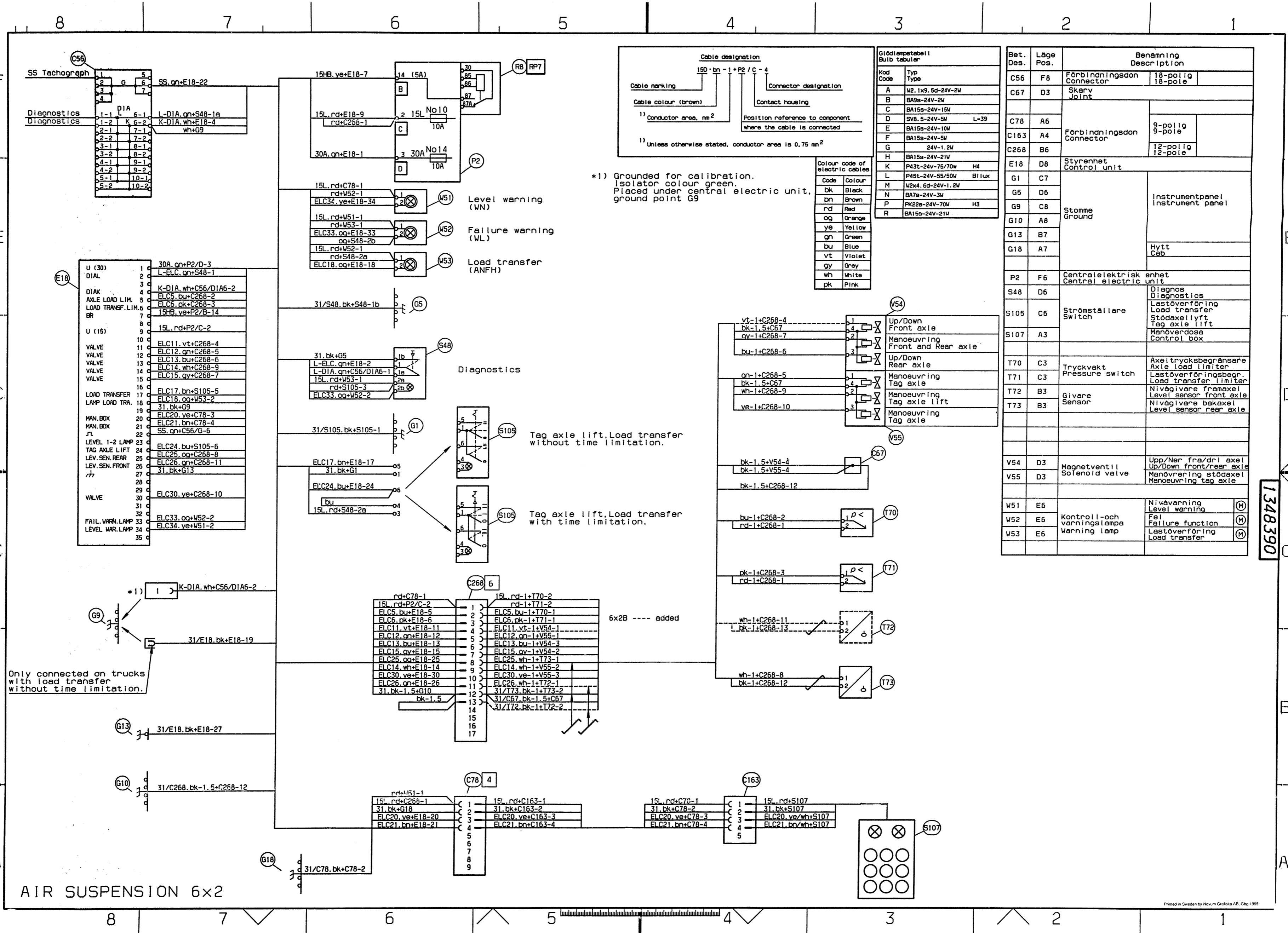

Glödlampstabell Bulb tabular

Kod Code	Typ Type
A	V2, 1x9, 5d-24V-2W
B	BA9s-24V-2W
C	BA15s-24V-15W
D	SV8, 5-24V-5W L-39
E	BA15s-24V-10W
F	BA15s-24V-5W
G	24V-1,2W
H	BA15s-24V-21W
K	P43t-24V-75/70W H4
L	P45t-24V-55/50W BILux
M	V2x4, 6d-24V-1,2W
N	BR7s-24V-3W
P	PK22s-24V-70W H3
R	BA15s-24V-21W

Colour code of electric cables

Code	Colour
bk	Black
bn	Brown
rd	Red
og	Orange
ye	Yellow
gn	Green
bu	Blue
vt	Violet
gy	Grey
wh	White
pk	Pink

Bet. Des.	Läge Pos.	Benämning Description
C56	F8	Förbindningsdon 18-poleg
C67	D3	Skarv Joint
C78	A6	Förbindningsdon 9-poleg
C163	A4	Förbindningsdon 12-poleg
C268	B6	Styrenhet Control unit
E18	D8	Styrenhet Control unit
G1	C7	Stomme Ground
G5	D6	
G9	C8	
G10	A8	
G13	B7	
G18	A7	Hytt Cab
P2	F6	Centralelektrisk enhet Central electric unit
S48	D6	Diagnos Diagnostics
S105	C6	Lastöverföring Load transfer
S107	A3	Stöddaxellyft Tag axle lift
T70	C3	Manöverdosan Control box
T71	C3	Manöverdosan Control box
T72	B3	Manöverdosan Control box
T73	B3	Manöverdosan Control box
V54	D3	Manöverdosan Control box
V55	D3	Manöverdosan Control box
W51	E6	Nivåvarning Level warning
W52	E6	Fel Failure function
W53	E6	Varning lampa Warning lamp

*1) Grounded for calibration. Isolator colour green. Placed under central electric unit, ground point G9

1348390

AIR SUSPENSION 6x2