

**16:04-45**

Edition 1

**Stödaxellyft, Axeltrycksbegränsare**

**Tag axle lift, Axle weight limiter**

**Achsenlift, Achsdruckbegrenzer**

**Sleepaslift, Asdrukbegrenzer**

**Dispositif de levage d'essieu,  
Limiteur de charge à l'essieu**

**Elevador del eje portador,  
Limitador de carga sobre ejes**

**Levantador do eixo de apoio, limitador de  
carga sobre o eixo**

**Sollevamento assale di supporto,  
Limitatore pressione assale**

**Tukiakselinnostin, Akselimassanrajoitin**

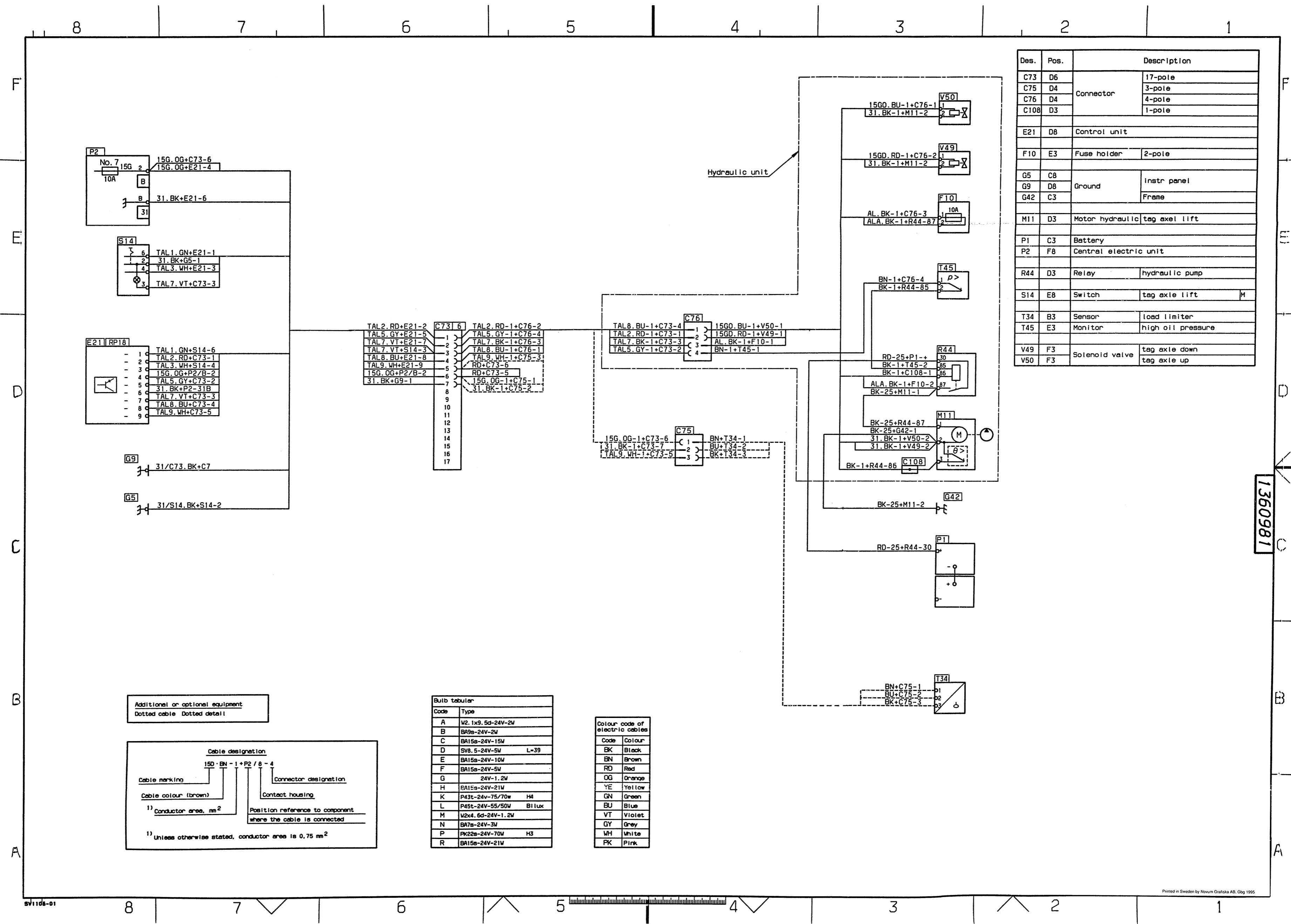

Des.	Pos.	Description
C73	D6	17-pole Connector
C75	D4	3-pole Connector
C76	D4	4-pole Connector
C108	D3	1-pole Connector
E21	D8	Control unit
F10	E3	Fuse holder 2-pole
G5	C8	Instr panel
G9	D8	Ground
G42	C3	Frame
M11	D3	Motor hydraulic tag axle lift
P1	C3	Battery
P2	F8	Central electric unit
R44	D3	Relay hydraulic pump
S14	E8	Switch tag axle lift
T34	B3	Sensor load limiter
T45	E3	Monitor high oil pressure
V49	F3	Solenoid valve tag axle down
V50	F3	Solenoid valve tag axle up

Additional or optional equipment  
Dotted cable Dotted detail

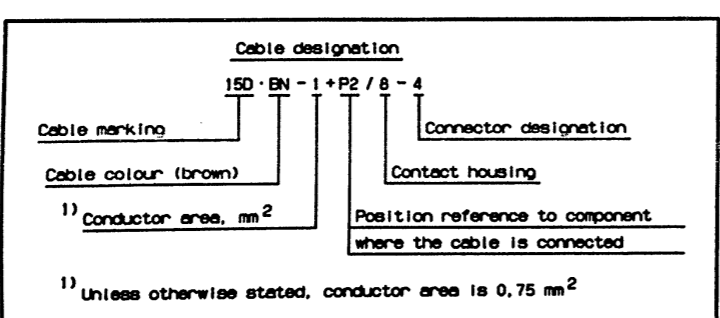

**Build tabular**

Code	Type
A	V2, 1x9, 5d-24V-2W
B	BA9s-24V-2W
C	BA15s-24V-15W
D	SV8, 5-24V-5W L=39
E	BA15s-24V-10W
F	BA15s-24V-5W
G	24V-1,2W
H	BA15s-24V-21W
K	P43t-24V-75/70W H4
L	P45t-24V-55/50W B1Lux
M	V2x4, 6d-24V-1,2W
N	BA7s-24V-3W
P	PK22s-24V-70W H3
R	BA15s-24V-21W

**Colour code of electric cables**

Code	Colour
BK	Black
BN	Brown
RD	Red
OG	Orange
YE	Yellow
GN	Green
BU	Blue
VT	Violet
GY	Grey
WH	White
PK	Pink

1360981