

16:04-46

Edition 1

ADR chassijordat system

ADR chassis earthed system

ADR-System, am Fahrgestell geerdet

ADR, systeem met chassisaarding

ADR, système mis à la masse sur châssis

**Sistema conectado a masa en chasis
según ADR**

ADR impianto con autotelaio a massa

ADR alustaan maatettu järjestelmä

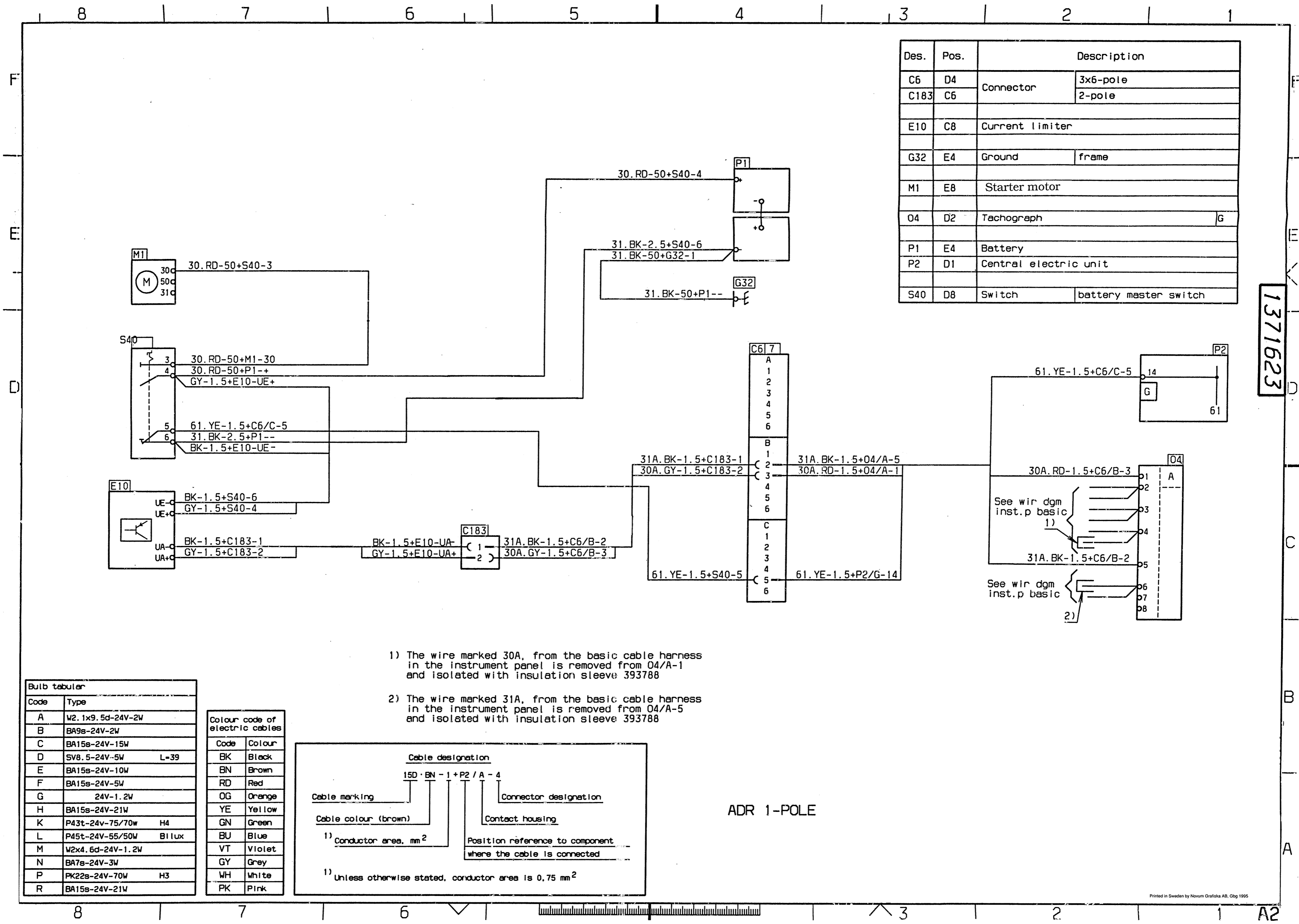

Des.	Pos.	Description	
C6	D4	Connector	3x6-pole
C183	C6		2-pole
E10	C8	Current limiter	
G32	E4	Ground	frame
M1	E8	Starter motor	
O4	D2	Tachograph	G
P1	E4	Battery	
P2	D1	Central electric unit	
S40	D8	Switch	battery master switch

1371623

Code	Type
A	W2. 1x9. 5d-24V-2W
B	BA9s-24V-2W
C	BA15s-24V-15W
D	SV8. 5-24V-5W L-39
E	BA15s-24V-10W
F	BA15s-24V-5W
G	24V-1.2W
H	BA15s-24V-21W
K	P43t-24V-75/70W H4
L	P45t-24V-55/50W B1lux
M	W2x4. 6d-24V-1.2W
N	BA7s-24V-3W
P	PK22s-24V-70W H3
R	BA15s-24V-21W

Code	Colour
BK	Black
BN	Brown
RD	Red
OG	Orange
YE	Yellow
GN	Green
BU	Blue
VT	Violet
GY	Grey
WH	White
PK	Pink

- 1) The wire marked 30A, from the basic cable harness in the instrument panel is removed from O4/A-1 and isolated with insulation sleeve 393788
- 2) The wire marked 31A, from the basic cable harness in the instrument panel is removed from O4/A-5 and isolated with insulation sleeve 393788

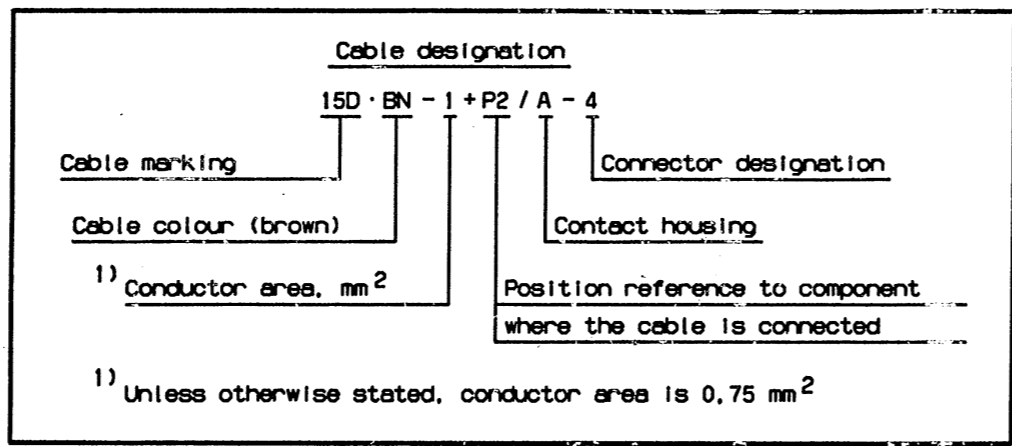

ADR 1-POLE