

16:14-03

Edition 1

Airbag och bältessträckare

Airbag and seat-belt tensioner

Airbag und Gurtstraffer

Airbag en gordelspanner

Airbag et tendeur de ceinture

Airbag y tensor de cinturón

Airbag e tendicinghia

Turvatyyny ja turvavyönkiristin

Poduszka ochronna i samonawijacz

Bulb tabular	
Code	Type
A	V2, 1x9, 5d-24V-2W
B	BA9s-24V-2W
C	BA15s-24V-15W
D	SV8, 5-24V-5W L=39
E	BA15s-24V-10W
F	BA15s-24V-5W
G	24V-1, 2W
H	BA15s-24V-21W
K	P43t-24V-75/70W H4
L	P45t-24V-55/50W B1 Lux
M	V2x4, 6d-24V-1, 2W
N	BA7s-24V-3W
P	PK22s-24V-70W H3
R	BA15s-24V-21W

Colour code of electric cables	
Code	Colour
BK	Black
BN	Brown
RD	Red
OG	Orange
YE	Yellow
GN	Green
BU	Blue
VT	Violet
GY	Grey
WH	White
PK	Pink

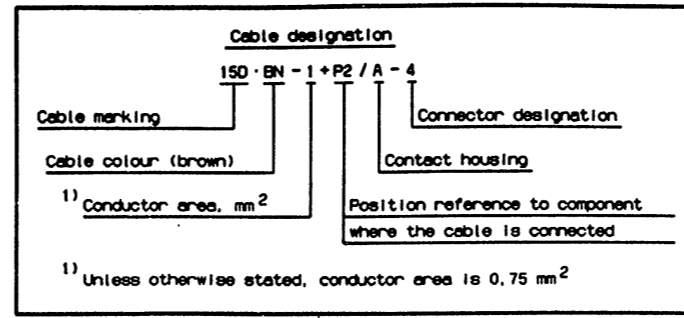

Additional or optional equipment
Dotted cable Dotted detail

Des.	Pos.	Description	
C16	C4	Connector	9-pole
C17	B7	Junction block	
C56	D7	Junction block	
C113	B5	Connector	9-pole
C289	D5		2-pole
C290	E5		
C340	B5		
C341	A7		
E11	D2	Control unit	airbag, belt pretensioner
G13	C7	Ground	front plate
H14	E3		airbag
H16	B6	Squib unit	seat belt driver side
H17	A8		pass side
P2	E7	Central electric unit	
U6	E4	Spring coil	airbag
U7	B5	Condenser	squib connector
U8	A8		
W57	C7	Warning lamp	airbag, belt tens fault M

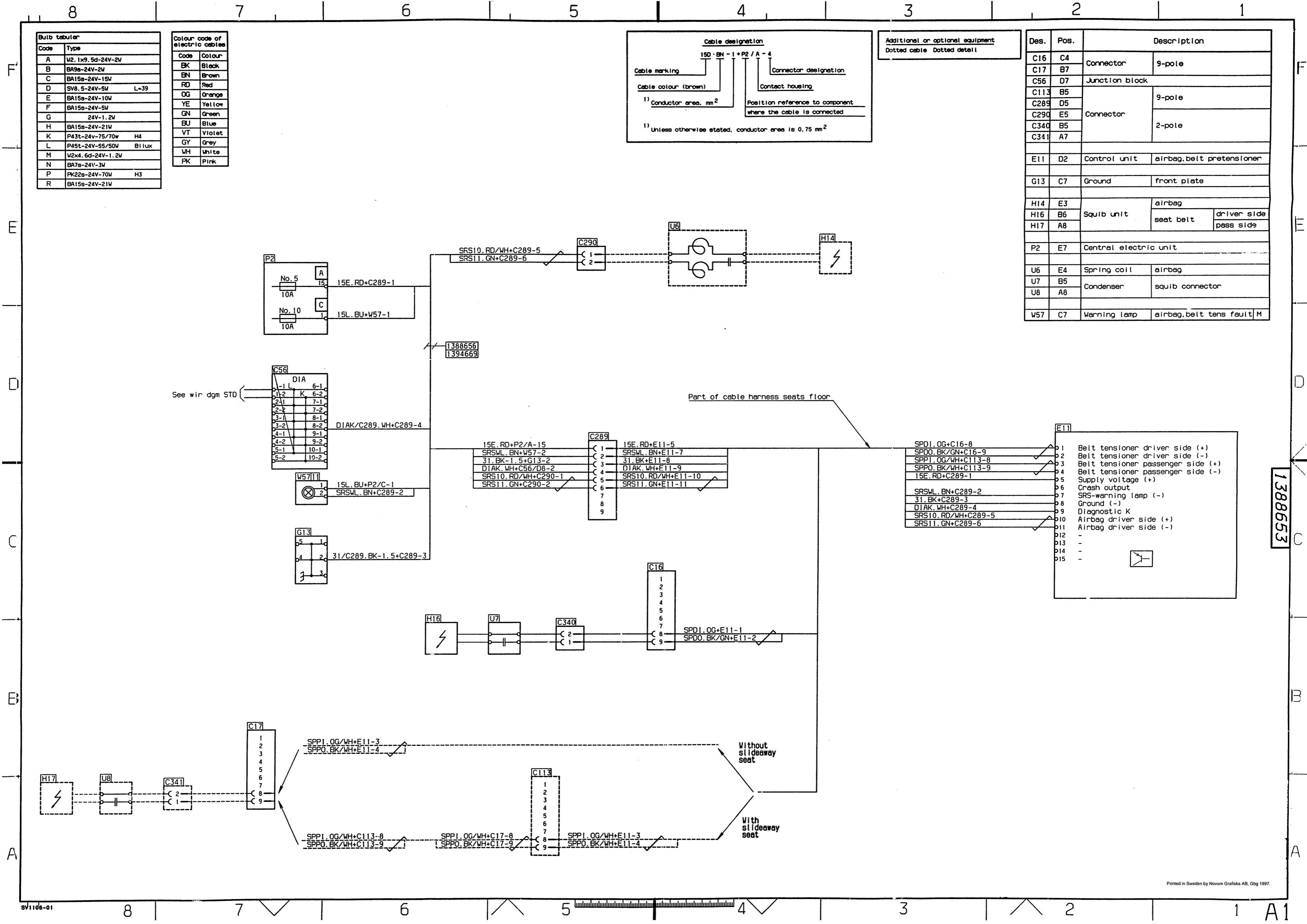

1388653

Printed in Sweden by Novum Grafiska AB, Gbg 1997.