



16:14-11

Utgåva/Issue/Ausgabe/Utgave/Edición/Edition/Edizione/Painos 1

Recirkulationsspjäll

Recirkulation damper

Umluftklappe

Recycleklep

Mariposa de recirculación

Volet de recirculation

Portellino ricircolo

Kierrätyslappä

Válvula de recirculcão

Fordon tillverkade efter 9804
Vehicles manufactured after 9804
Fahrzeug gebaut nach 9804
Na 0498 gefabriceerde voertuigen
Vehículos fabricados después de 9804
Véhicules fabriqués après 9804
Veicoli realizzati dopo il 04/98
Ennen 9804 valmistetut ajoneuvot
Veículos fabricados após 9804

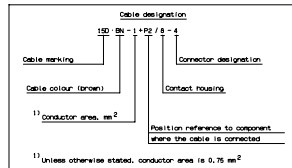
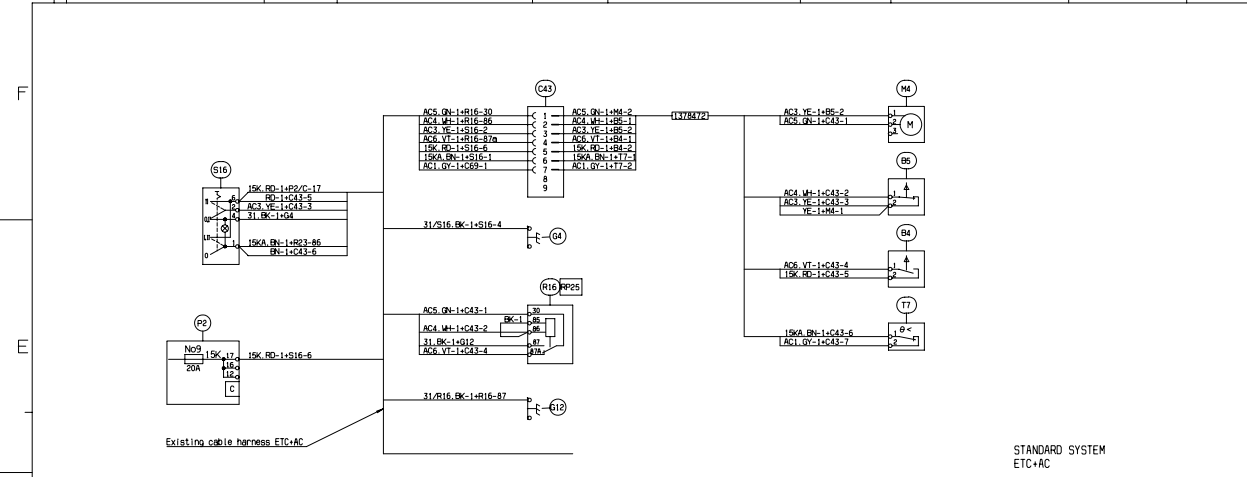

Colour code of electric cables	
Code	Colour
BN	Black
BR	Brown
RD	Red
OD	Orange
YL	Yellow
GN	Green
BL	Blue
VT	Violet
GY	Grey
WH	White
PK	Pink

Des.	Pos.	Description
B4	Switch	Recirc. damper closed *1)
B5	Switch	Recirc. damper open *2)
C43	Contactor	3-pole
G4	Ground	Instrument panel
G12	Ground	Central electric unit
M4	Shifting motor	Recirculation valve
P2	Relay	Central electric unit
R16	Relay	Shifting motor
S16	Switch	Air condition
S68	Switch	Recirculation
T7	Monitor	Low temperature

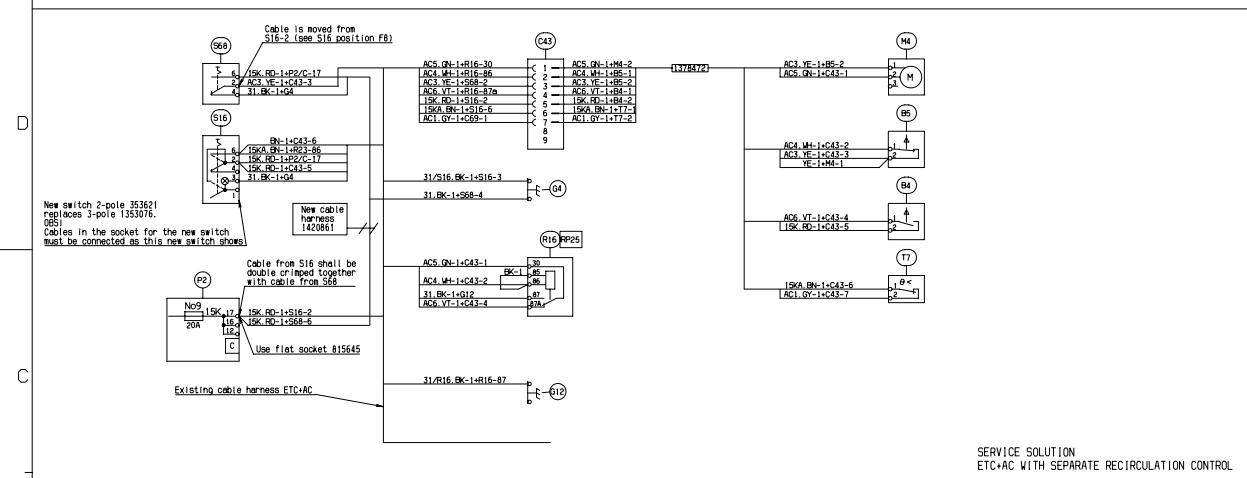

- *1) When the valve is closed, the current path in B4 is interrupted.
- *2) When the valve is open, the current path in B5 is interrupted.

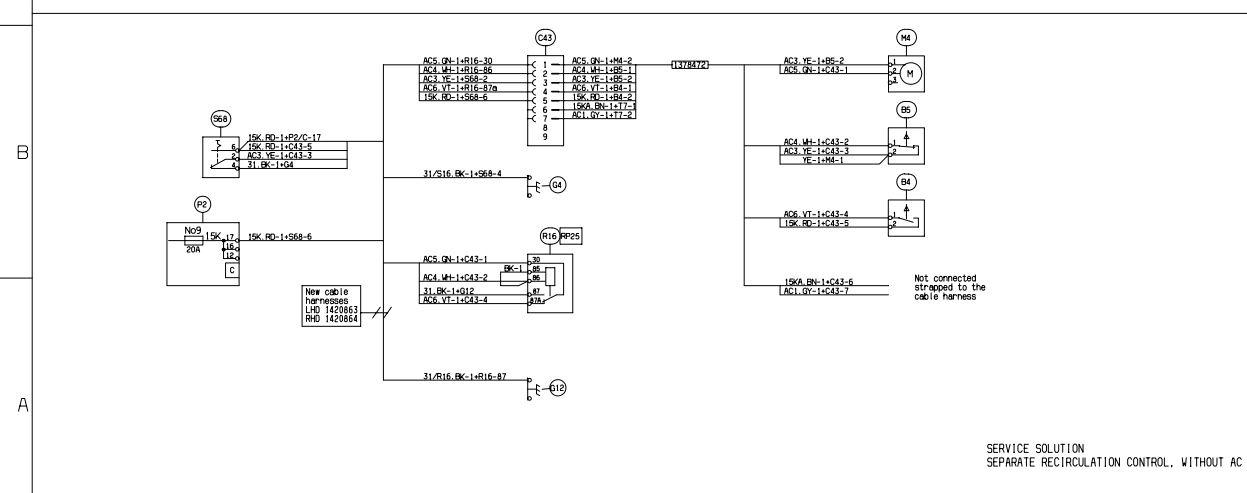

Service solution

Circuit Protection also to STD 3964	
<C>	: 0
<M>	: 0
<D>	: 0
<L>	: 0