

16:14-34

Edition 2

Retarder med automatisk avgasbroms (EEB)

Retarder with automatic exhaust brake (EEB)

Retarder mit automatischer Abgasbremse (EEB)

Retarder met autom. uitlaatrem (EEB)

Ralentisseur avec ralentisseur sur échappement automatique (EEB)

Ralentizador con freno de escape automático (EEB)

Retardador com freio motor (travão de escape) automático (EEB)

Rallentatore con freno motore automatico (EEB)

Hidastin ja aut. pakokaasujarru (EEB)

Retarder z automatycznym hamulcem wydechowym (EEB)

Fordon tillverkade efter 9908
Vehicles manufactured after 9908
Fahrzeug gebaut nach 9908
Na 9908 gefabriceerde voertuigen
Véhicules fabriqués après 9908
Vehículos fabricados después de 9908
Veículos fabricados após 9908
Veicoli realizzati dopo il 08/99
9908 jälkeen valmistetut ajoneuvot
Pojazdy produkowane po 9908

1424657

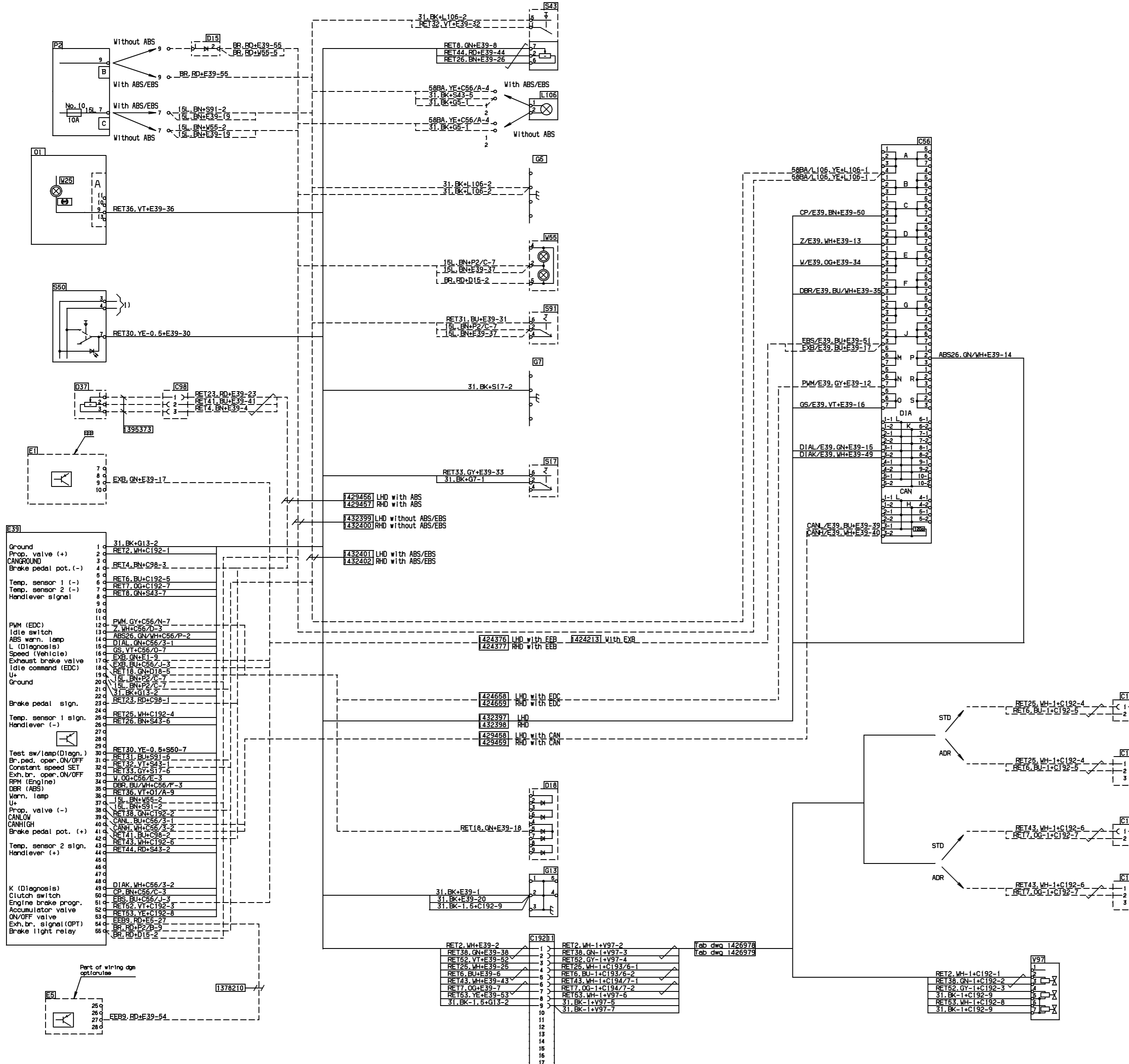

Des.	Pos.	Description
C66	E4	Junction block
C98	D7	3-pole
C192	A6	17-pole
C193	C3	Connector
C194	B3	2-pole
C196	B3	3-pole
C197	B3	3-pole
D15	F7	Diode
D18	B6	Diode unit
D37	D8	Potentiometer
E1	D8	exhaust brake, white sm 11e
E5	A8	Control unit
E39	C8	Retarder
G5	E6	Instr. panel
G7	D6	Ground
G13	B6	front plate
L106	F6	Symbol lighting
O1	E8	Combination instrument
P2	F8	Central electric unit
S17	D6	aut exhaust brake on/off
S43	F6	retarder
S50	E8	Switch
S91	E6	ret. brake pedal on/off
T63	C2	coolant temp. 1 retarder
T64	B2	coolant temp. 2 retarder
V97	A3	Solenoid valve unit
W25	E8	Warning lamp
W55	E6	retarder in operation

1) See wiring diagram Diagnostics