

16:14-35/2

Utgåva/Issue/Ausgabe/Uitgave/Edición/Edition/Edizione/Painos 1

EBS 2.2

SSS 1 254 424

SAN 9 046 543

SNL 4 420 708

**Förbindningschema, Wiring Diagram, Verbindungsplan,
Bedradingsschema, Diagrama de conexiones, Schéma de
réalisation, Schema dei collegamenti, KytKentäkaavio, Dia-
grama de conexões**

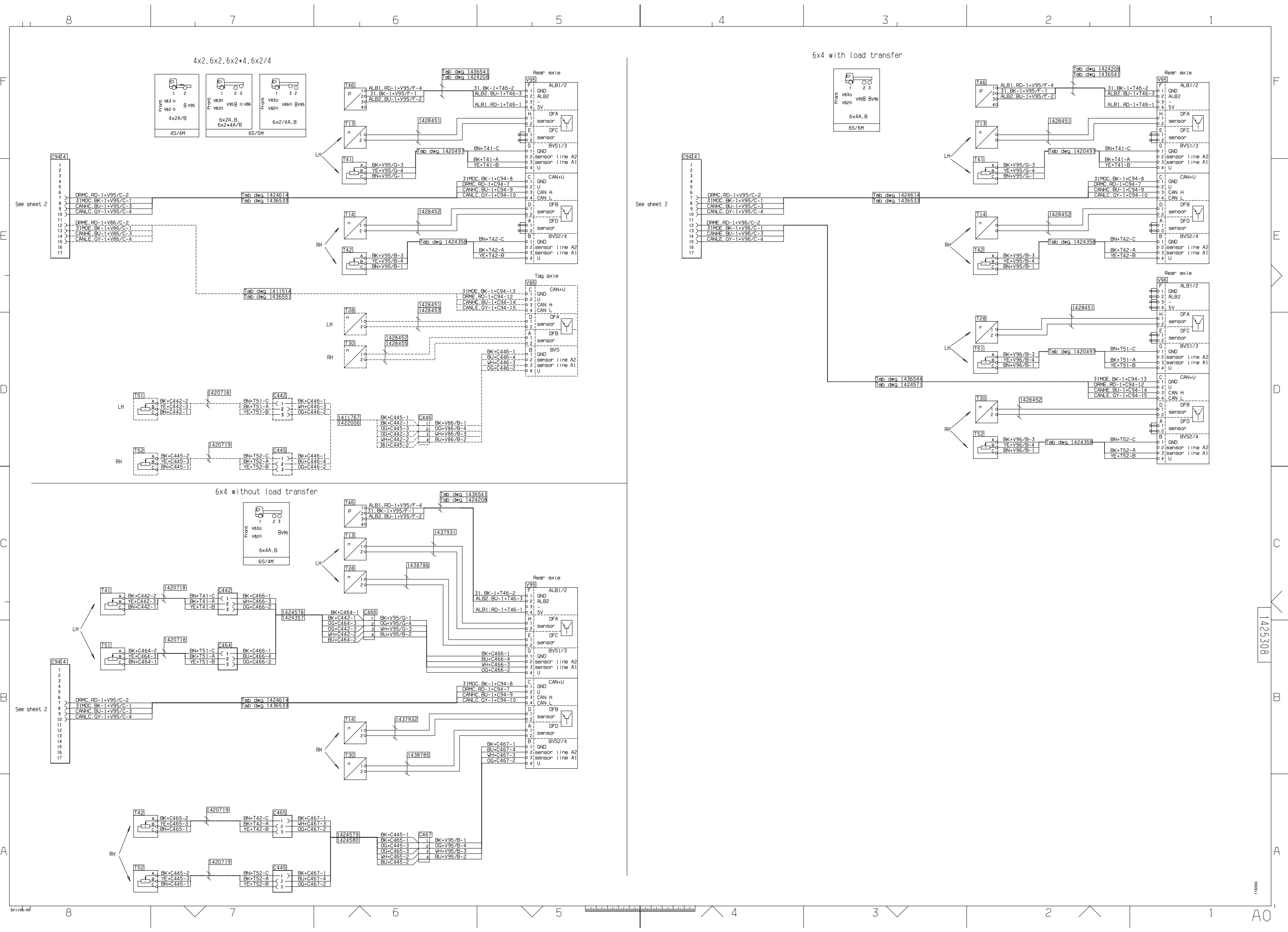

1425308

980311