

# 16:14-42

Edition 1

**SCANIA**

**Luftjädring - elektroniskt styrd (ELC)**  
4x2 samt 6x4, 8x4 utan lastöverföring

**Air suspension, electronically controlled (ELC)**  
4x2 and 6x4, 8x4 without load transfer

**Luftfederung - elektronisch gesteuert (ELC)**  
4x2 und 6x4, 8x4 ohne Lastübertragung

**Luchtvering - elektronisch gestuurd (ELC)**  
4x2 en 6x4, 8x4 zonder lastoverheveling

**Suspension - commande électronique (ELC)**  
4x2 et 6x4, 8x4 sans report de charge

**Suspensión neumática - mando electrónico (ELC)**  
4x2 y 6x4, 8x4 sin transferencia de la carga

**Suspensão pneumática controlada eletronicamente (ELC)**  
4x2 e 6x4, 8x4 sem transferência de carga

**Sospensione pneumatica a comando elettronico (ELC)**  
4x2 e 6x4, 8x4 senza trasferimento del carico

**Ilmajousitus - elektronisesti ohjattu (ELC)**  
4x2 sekä 6x4, 8x4 ilman painonsiirtoa

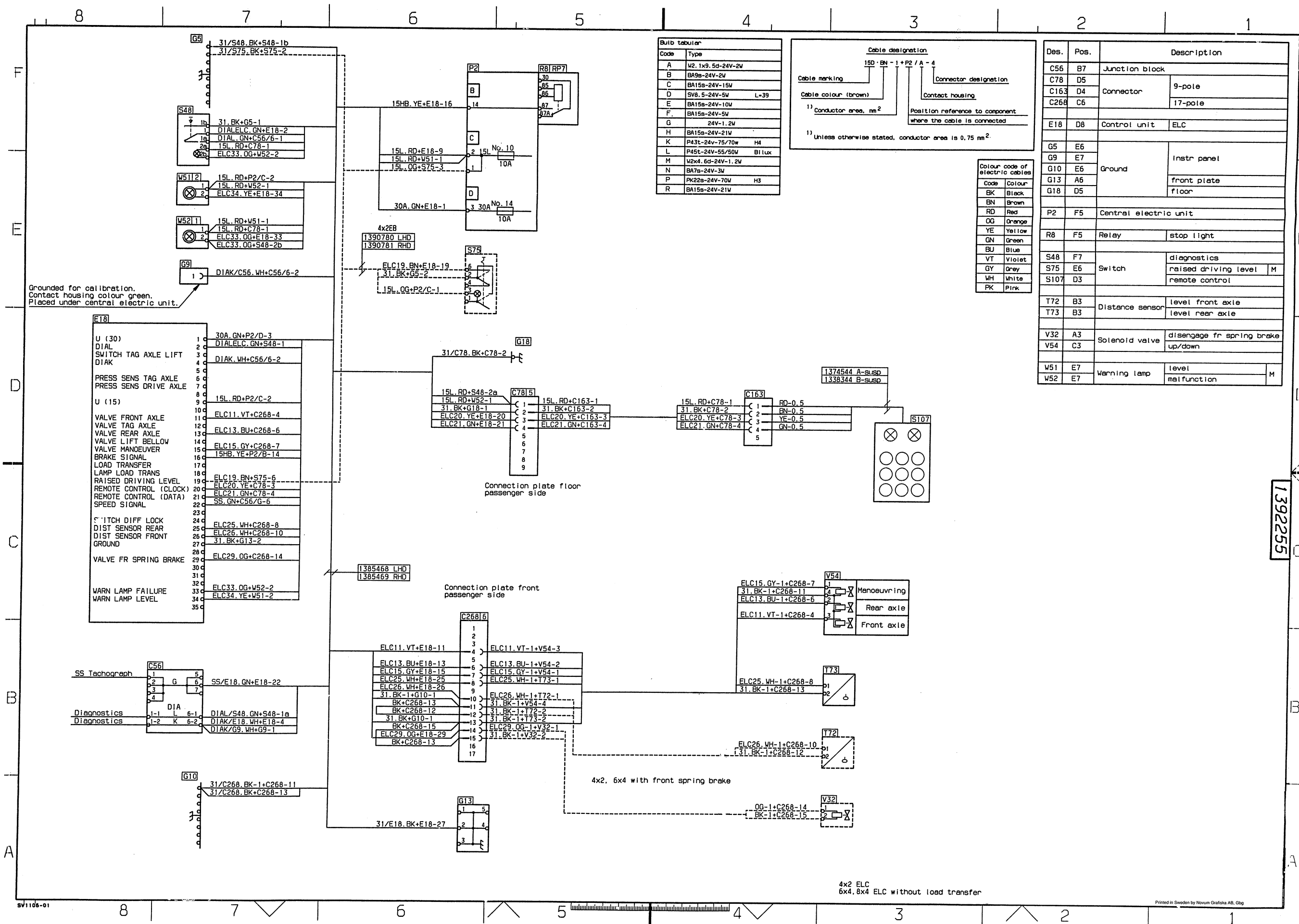

**Bulb tabular**

Code	Type
A	W2, 1x9, 5d-24V-2W
B	BA9s-24V-2W
C	BA15s-24V-15W
D	SV8, 5-24V-5W L=39
E	BA15s-24V-10W
F	BA15s-24V-5W
G	24V-1,2W
H	BA15s-24V-21W
K	P43t-24V-75/70w H4
L	P45t-24V-55/50W BILux
M	W2x4, 6d-24V-1,2W
N	BA7s-24V-3W
P	PK22s-24V-70W H3
R	BA15s-24V-21W

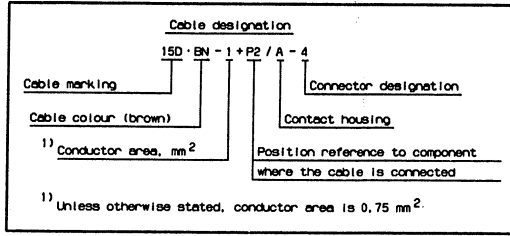

**Colour code of electric cables**

Code	Colour
BK	Black
BN	Brown
RD	Red
OG	Orange
YE	Yellow
GN	Green
BU	Blue
VT	Violet
GY	Grey
WH	White
PK	Pink

Des.	Pos.	Description
C56	B7	Junction block
C78	D5	Connector 9-pole
C163	D4	
C268	C6	17-pole
E18	D8	Control unit ELC
G5	E6	Ground Instr panel
G9	E7	
G10	E6	
G13	A6	front plate
G18	D5	floor
P2	F5	Central electric unit
R8	F5	Relay stop light
S48	F7	diagnostics
S75	E6	Switch raised driving level M
S107	D3	remote control
T72	B3	Distance sensor level front axle
T73	B3	level rear axle
V32	A3	Solenoid valve disengage fr spring brake
V54	C3	up/down
W51	E7	Warning lamp level M
W52	E7	malfunction

Grounded for calibration.  
Contact housing colour green.  
Placed under central electric unit.

Connection plate floor passenger side

Connection plate front passenger side

4x2, 6x4 with front spring brake

4x2 ELC  
6x4, 8x4 ELC without load transfer

1392255