

16:14-42

Edition 1

SCANIA

Luftjädring - elektroniskt styrd (ELC)
4x2 samt 6x4, 8x4 utan lastöverföring

Air suspension, electronically controlled (ELC)
4x2 and 6x4, 8x4 without load transfer

Luftfederung - elektronisch gesteuert (ELC)
4x2 und 6x4, 8x4 ohne Lastübertragung

Luchtvering - elektronisch gestuurd (ELC)
4x2 en 6x4, 8x4 zonder lastoverheveling

Suspension - commande électronique (ELC)
4x2 et 6x4, 8x4 sans report de charge

Suspensión neumática - mando electrónico (ELC)
4x2 y 6x4, 8x4 sin transferencia de la carga

Suspensão pneumática controlada eletronicamente (ELC)
4x2 e 6x4, 8x4 sem transferência de carga

Sospensione pneumatica a comando elettronico (ELC)
4x2 e 6x4, 8x4 senza trasferimento del carico

Ilmajousitus - elektronisesti ohjattu (ELC)
4x2 sekä 6x4, 8x4 ilman painonsiirtoa

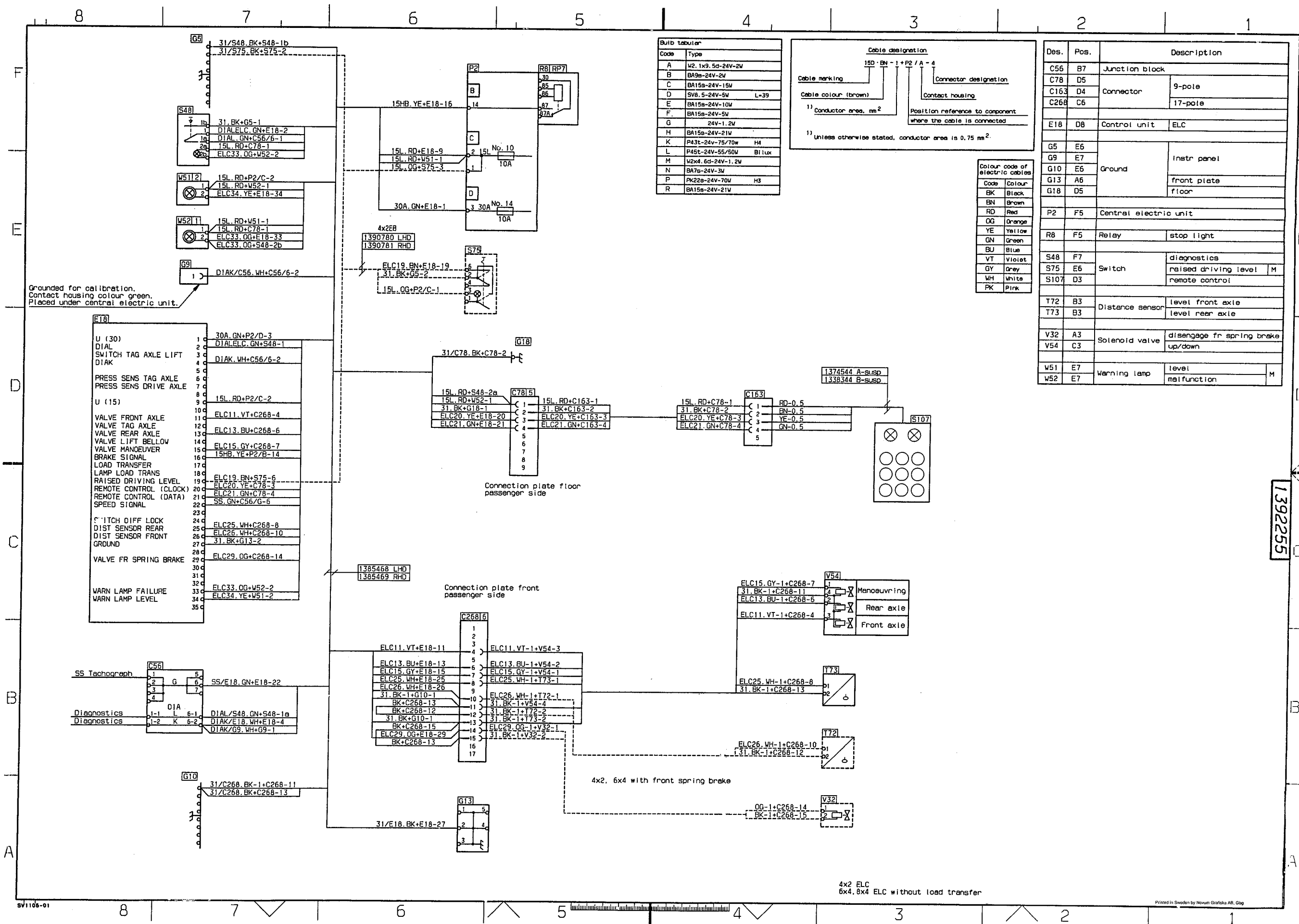

Bulb tabular

Code	Type
A	W2, 1x9, 5d-24V-2W
B	BA9s-24V-2W
C	BA15s-24V-15W
D	SV8, 5-24V-5W L=39
E	BA15s-24V-10W
F	BA15s-24V-5W
G	24V-1,2W
H	BA15s-24V-21W
K	P43t-24V-75/70w H4
L	P45t-24V-55/50W B1lux
M	W2x4, 6d-24V-1,2W
N	BA7s-24V-3W
P	PK22s-24V-70W H3
R	BA15s-24V-21W

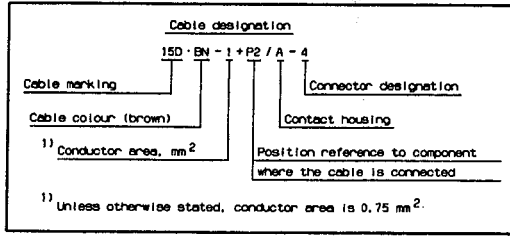

Colour code of electric cables

Code	Colour
BK	Black
BN	Brown
RD	Red
OG	Orange
YE	Yellow
GN	Green
BU	Blue
VT	Violet
GY	Grey
WH	White
PK	Pink

Des.	Pos.	Description
C56	B7	Junction block
C78	D5	Connector 9-pole
C163	D4	Connector 17-pole
C268	C6	Connector 17-pole
E18	D8	Control unit ELC
G5	E6	
G9	E7	Instr panel
G10	E6	Ground
G13	A6	front plate
G18	D5	floor
P2	F5	Central electric unit
R8	F5	Relay stop light
S48	F7	diagnostics
S75	E6	Switch raised driving level M
S107	D3	remote control
T72	B3	Distance sensor level front axle
T73	B3	Distance sensor level rear axle
V32	A3	Solenoid valve disengage fr spring brake
V54	C3	Solenoid valve up/down
W51	E7	Warning lamp level M
W52	E7	Warning lamp malfunction M

Grounded for calibration.
Contact housing colour green.
Placed under central electric unit.

1392255

4x2 ELC
6x4, 8x4 ELC without load transfer