



16:14-43

Edition 1

ELC

Luftfjädring - elektroniskt styrd

Air suspension, electronically controlled

Luftfederung - elektronisch gesteuert

Luchtvering - elektronisch gestuurd

Suspension - commande électronique

Suspensión neumática - mando electrónico

Suspensão pneumática controlada eletronicamente

Sospensione pneumatica a comando elettronico

Ilmajousitus - elektronisesti ohjattu

6x2, 6x2/4, 8x2

From chassis No. 1 207 526

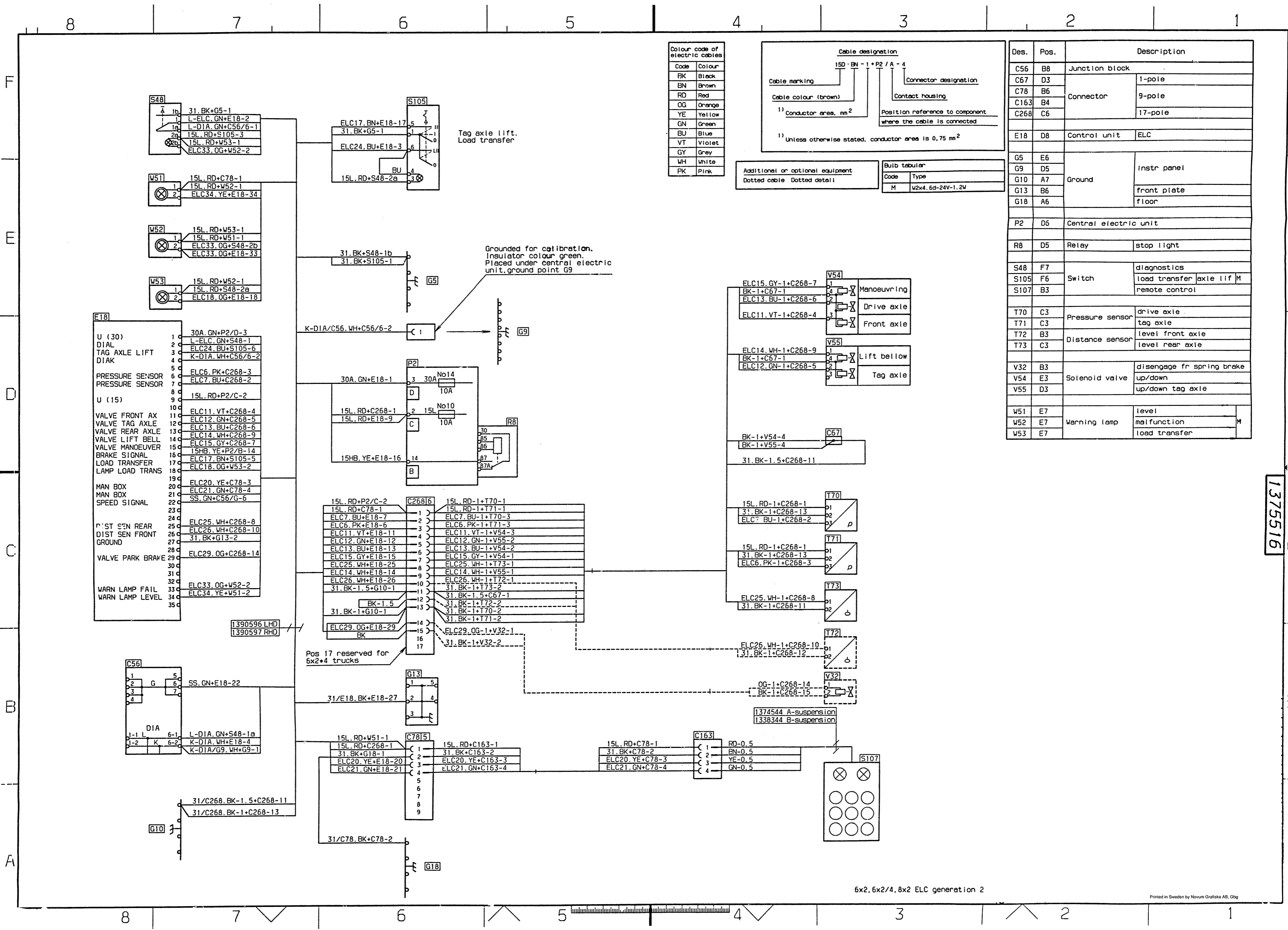

Colour code of electric cables

Code	Colour
BK	Black
BN	Brown
RD	Red
OG	Orange
YE	Yellow
GN	Green
BU	Blue
VT	Violet
GY	Grey
WH	White
PK	Pink

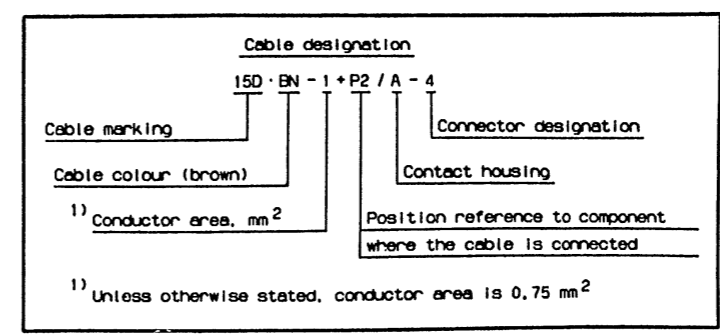

Additional or optional equipment

Code	Type
M	W2x4.6x-24V-1.2V

Des.	Pos.	Description	
C56	B8	Junction block	
C67	D3	1-pole	
C78	B6	Connector	
C163	B4		9-pole
C268	C6	17-pole	
E18	D8	Control unit	
G5	E6	Ground	
G9	D5		Instr panel
G10	A7		front plate
G18	A6		floor
P2	D5	Central electric unit	
R8	D5	Relay	
S48	F7	diagnostics	
S105	F6	Switch	
S107	B3	load transfer axle lift remote control	
T70	C3	Pressure sensor	
T71	C3	drive axle tag axle	
T72	B3	Distance sensor	
T73	C3	level front axle level rear axle	
V32	B3	disengage fr spring brake	
V54	E3	Solenoid valve	
V55	D3	up/down tag axle	
W51	E7	Warning lamp	
W52	E7	level malfunction	
W53	E7	load transfer	

1375516