

SCANIA

16:14-44

Edition 1

Luftfjädring - manuellt styrd, 4x2

Air suspension, manually controlled 4x2

Luftfedreung - manuellt gesteuert, 4x2

Luchtvering - handmatig geregeld, 4x2

Suspension - commande manuelle 4x2

Suspensión neumática - mando manual, 4x2

Suspensão pneumática controlada manualmente, 4x2

Sospensione pneumatica a comando manuale 4x2

Ilmajousitus - manuaalisesti ohjattu, 4x2

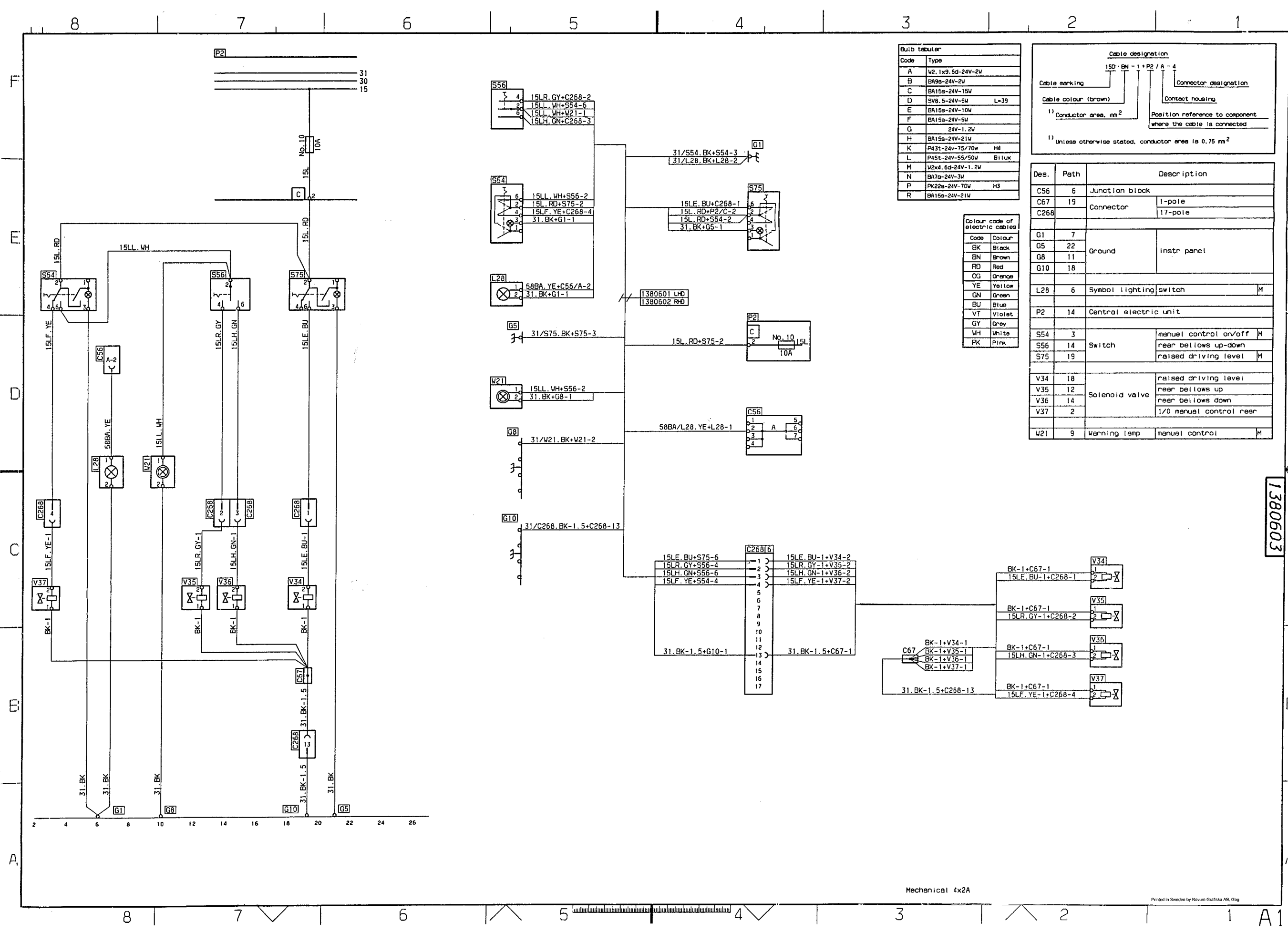

Bulb tabular

Code	Type
A	U2. 1x9. 5d-24V-2W
B	BA9s-24V-2W
C	BA15s-24V-15W
D	SV8. 5-24V-5W L=39
E	BA15s-24V-10W
F	BA15s-24V-5W
G	24V-1. 2W
H	BA15s-24V-21W
K	P43t-24V-75/70w H4
L	P45t-24V-55/50W Bilux
M	U2x4. 6d-24V-1. 2W
N	BA7s-24V-3W
P	PK22s-24V-70W H3
R	BA15s-24V-21W

Colour code of electric cables

Code	Colour
BK	Black
BN	Brown
RD	Red
OG	Orange
YE	Yellow
GN	Green
BU	Blue
VT	Violet
GY	Grey
WH	White
PK	Pink

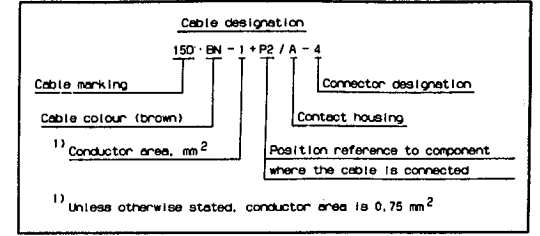

Des.	Path	Description
C56	6	Junction block
C67	19	Connector
C268		17-pole
G1	7	
G5	22	Ground
G8	11	instr panel
G10	18	
L28	6	Symbol lighting switch M
P2	14	Central electric unit
S54	3	manual control on/off M
S55	14	Switch rear bellows up-down
S75	19	Switch rear bellows level raised driving M
V34	18	Solenoid valve raised driving level
V35	12	Solenoid valve rear bellows up
V36	14	Solenoid valve rear bellows down
V37	2	1/0 manual control rear
W21	9	Warning lamp manual control M

Mechanical 4x2A

Printed in Sweden by Novum Grafiska AB, Göteborg

1380603

cardiagn.com