

# 16:14-45

Edition 1

**Luftfjädring - elektroniskt styrd (ELC)**  
6x4 och 8x4 med lastöverföring

**Air suspension, electronically controlled (ELC)**  
6x4 and 8x4 with load transfer

**Luftfederung - elektronisch gesteuert (ELC)**  
6x4 und 8x4 mit Lastübertragung

**Luchtvering - elektronisch gestuurd (ELC)**  
6x4 en 8x4 met lastoverheveling

**Suspension - commande électronique (ELC)**  
6x4 et 8x4 par report de charge

**Suspensión neumática - mando electrónico (ELC)**  
6x4 y 8x4 con transferencia de la carga

**Suspensão pneumática controlada eletronicamente (ELC)**  
6x4 e 8x4 com transferência de carga

**Sospensione pneumatica a comando elettronico (ELC)**  
6x4 e 8x4 con trasferimento del carico

**Ilmajousitus - elektronisesti ohjattu (ELC)**  
6x4 sekä 8x4 ja painonsiirtoa

From chassis No. 1 207 526

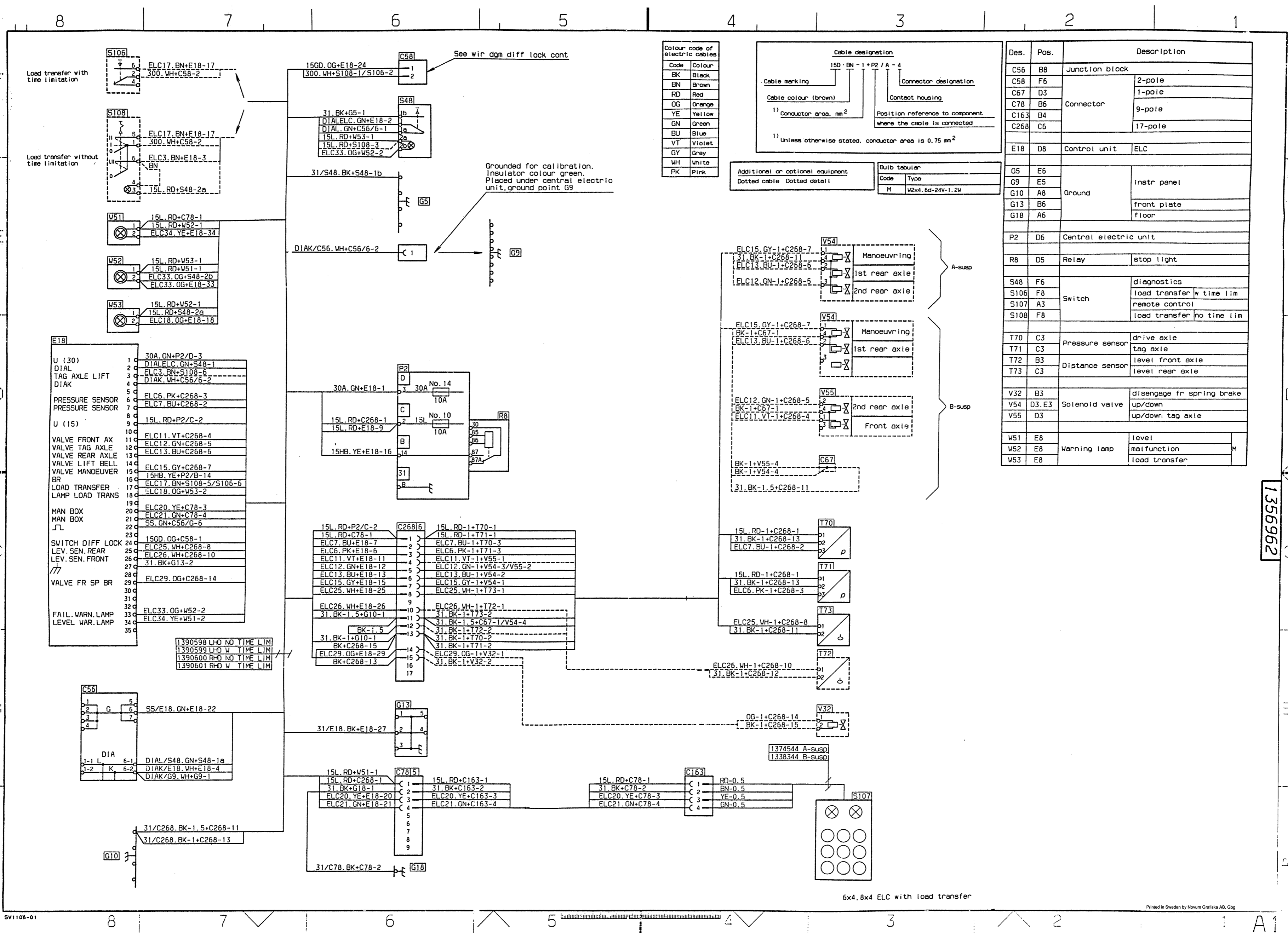

Des.	Pos.	Description	
C56	B8	Junction block	
C58	F6	2-pole	
C67	D3	1-pole	
C78	B6	Connector	
C163	B4		9-pole
C268	C6		17-pole
E18	D8	Control unit ELC	
G5	E6	Ground	
G9	E5		instr panel
G10	A8		front plate
G18	A6		floor
P2	D6	Central electric unit	
R8	D5	Relay stop light	
S48	F6	Switch	
S106	F8		diagnostics
S107	A3		load transfer w time lim
S108	F8	remote control	
T70	C3	Pressure sensor	
T71	C3		drive axle
T72	B3		tag axle
T73	C3	level front axle	
V32	B3	Distance sensor	
V54	D3.E3		level rear axle
V55	D3	disengage fr spring brake	
V54	D3.E3	Solenoid valve	
V55	D3		up/down
V51	E8	Warning lamp	
V52	E8		up/down tag axle
V53	E8		level
		malfunction	
		load transfer	

1356962

6x4, 8x4 ELC with load transfer