



# 16:15-11

Utgåva/Issue/Ausgabe/Uitgave/Edición/Edition/Edizione/Painos 1

**Recirkulationsspjäll**

**Recirkulation damper**

**Umluftklappe**

**Recycleklep**

**Mariposa de recirculación**

**Volet de recirculation**

**Portellino ricircolo**

**Kierrätyslappä**

**Válvula de recirculcão**

Fordon tillverkade efter 9804  
Vehicles manufactured after 9804  
Fahrzeug gebaut nach 9804  
Na 0498 gefabriceerde voertuigen  
Vehículos fabricados después de 9804  
Véhicules fabriqués après 9804  
Veicoli realizzati dopo il 04/98  
Ennen 9804 valmistetut ajoneuvot  
Veículos fabricados após 9804

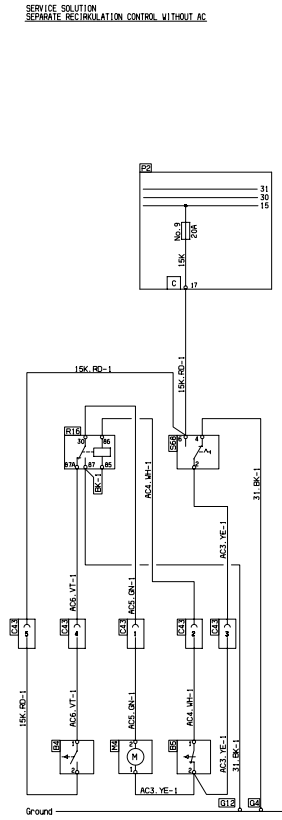
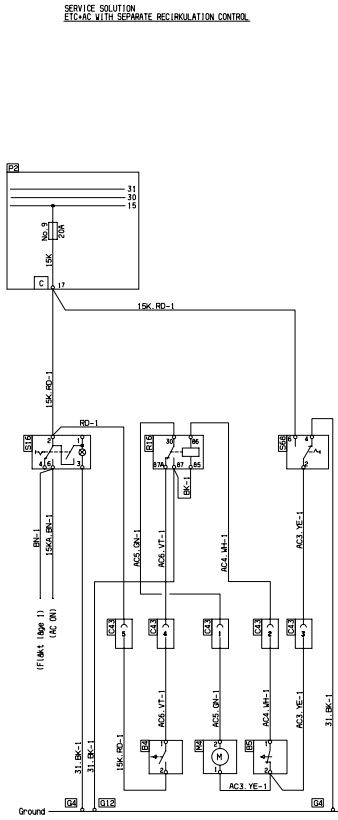
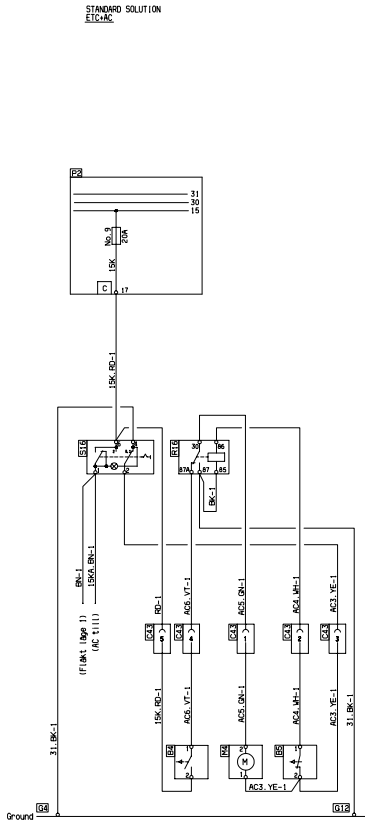

Des.	Path	Description
B4		recirc damper closed
B5		recirc damper open
C43		9-pole
G4		instr panel
G12		extra el central
M4		shifting motor recirculation valve
P2		Central electric unit
R16		Relay air condition
S16		air condition
S58		recirculation

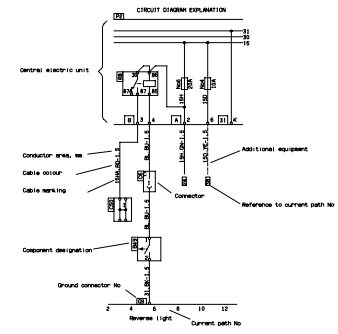

Service solution