



**16:52-57**

Utgåva/Issue/Ausgabe/Utgave/Edición/Édition/Edizione/Painos 1

**Nod H**

**Node H**

**Knoten H**

**Vertakkingspunt H**

**Nodo H**

**Nod H**

**Nod H**

**Noodi H**

8 7 6 5 4 3 2 1

F  
E  
D  
C  
B  
A

F  
E  
D  
C  
B  
A

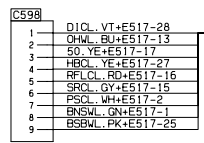
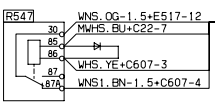
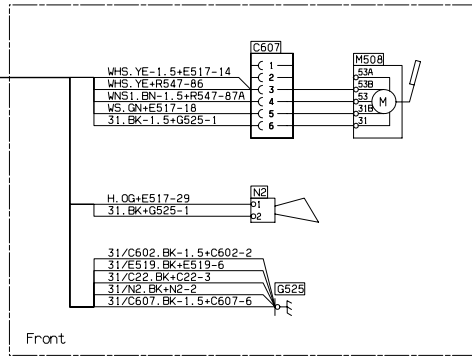
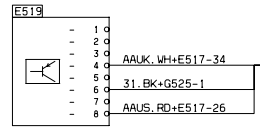
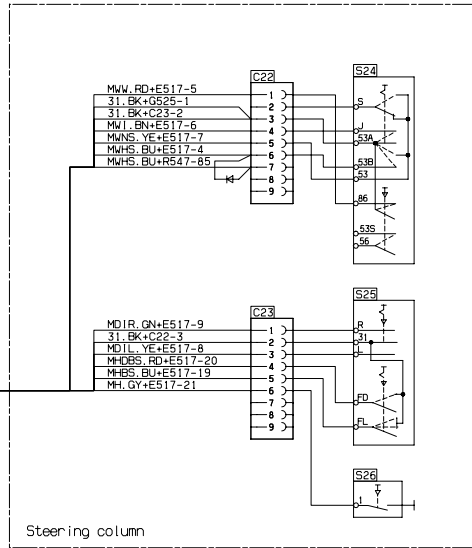
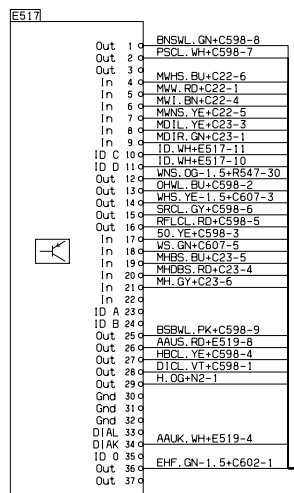

See diagram for chassis

Below instrument panel

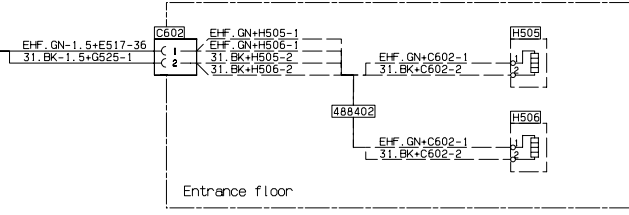

Des.	Pos.	Description	
C22	F4	Connector	9-pole
C23	E4		
C598	B8		
C602	B5		
C607	C4	2-pole	6-pole
E517	F8	Node	H
E519	D8	Audible alarm unit	
G525	B4	Ground	
H505	B4	Heating element	entrance door
H506	A4		
M508	C4	Motor	Windscreen wipers
N2	C4	Signal horn	
R547	C8	Relay	windscreen wipers
S24	F4	Switch	windscreen wiper, washer dir ind l, full/dip beam
S25	E4		
S26	D4		signal horn

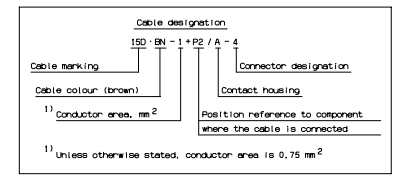

Additional or optional equipment  
Dotted cable Dotted detail

Power supply and communication for nodes are located on a separate drawing.

Colour code of electric cables	
Code	Colour
BK	Black
BN	Brown
RD	Red
OG	Orange
YE	Yellow
GN	Green
BU	Blue
VT	Violet
GY	Grey
WH	White
PK	Pink

488202

110647

8 7 6 5 4 3 2 1 A1