

SCANIA

16:54-24

Edition 1

Diffspärrar

Differential Lock

Differentialsperren

Differentieelsloten

Blocages de différentiels

Bloqueos del diferencial

Trava do diferencial

Blocco differenziale

Tasauspyörästön lukot

**Förbindningschema, Wiring Diagram, Verbindungsplan,
Bedradingsschema, Schéma de réalisation, Diagrama de
conexiones, Diagrama de conexões, Schema dei collega-
menti, KytKentäkaavio**

K/L

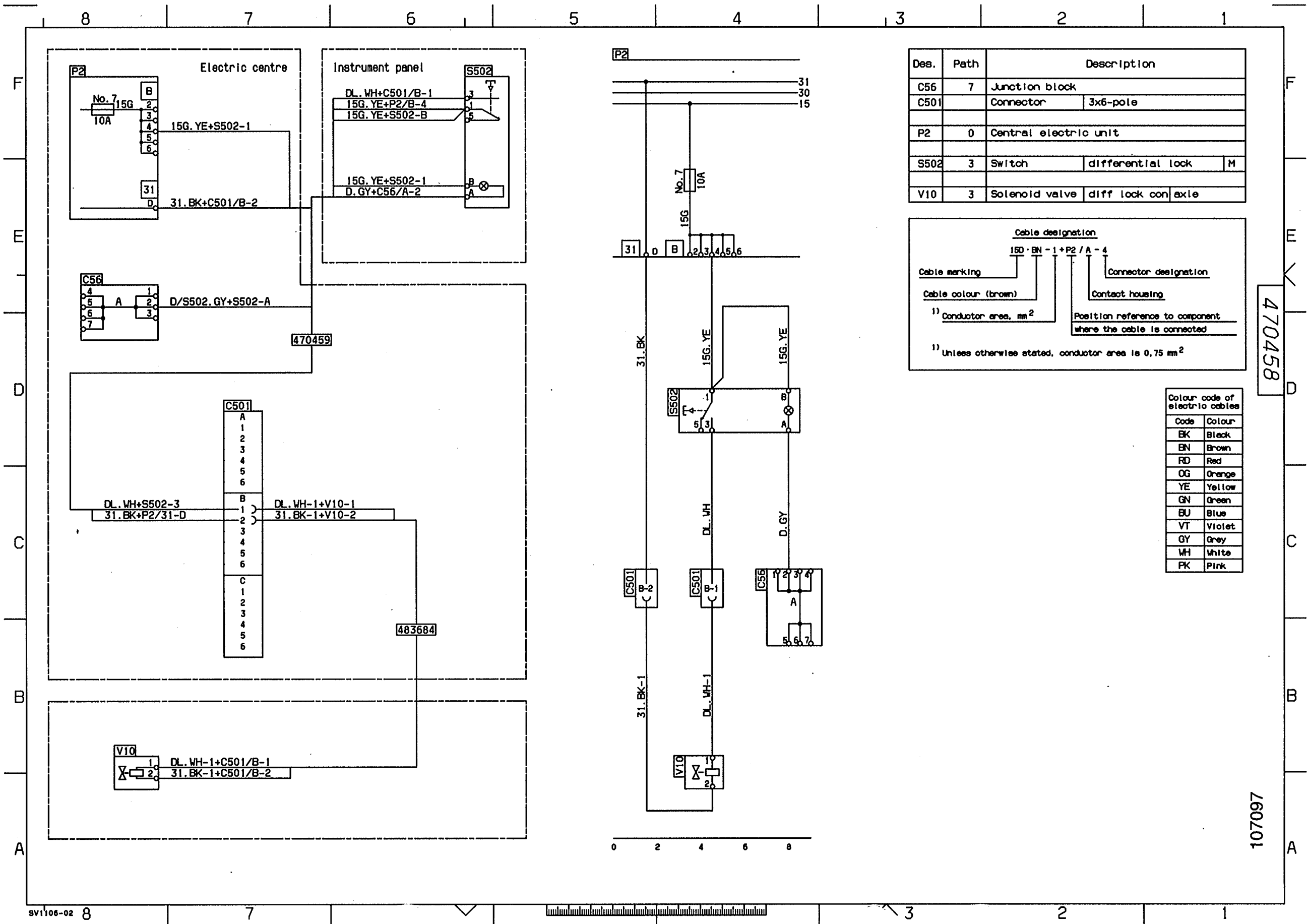

Des.	Path	Description
C56	7	Junction block
C501		Connector 3x6-pole
P2	0	Central electric unit
S502	3	Switch differential lock M
V10	3	Solenoid valve diff lock con axle

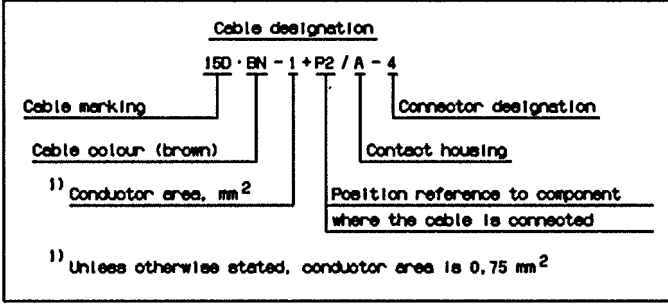

Colour code of electric cables	
Code	Colour
BK	Black
BN	Brown
RD	Red
OG	Orange
YE	Yellow
GN	Green
BU	Blue
VT	Violet
GY	Grey
WH	White
PK	Pink

470458

107097