

# 16:54-35

Edition 1

**Ledkontrollsystem, generation 3**

**Articulation control system, generation 3**

**Gelenkregelung, Generation 3**

**Scharniercontrolesysteem, generatie 3**

**Système de contrôle d'articulation, génération 3**

**Sistema de control de la articulación, generación 3**

**Sistema de controle de articulação, geração 3**

**Sistema controllo articolazione, generazione 3**

**Nivelenohjausjärjestelmä, sukupolvi 3**

**Układ sterowania przegubem, pokolenie 3**

**Förbindningschema, Wiring Diagram, Verbindungsplan, Bedradingsschema, Schéma de câblage, Diagrama de conexiones, Diagrama de conexões, Schema del collegamento, Kytentäkaavio, Schemat połączeń**

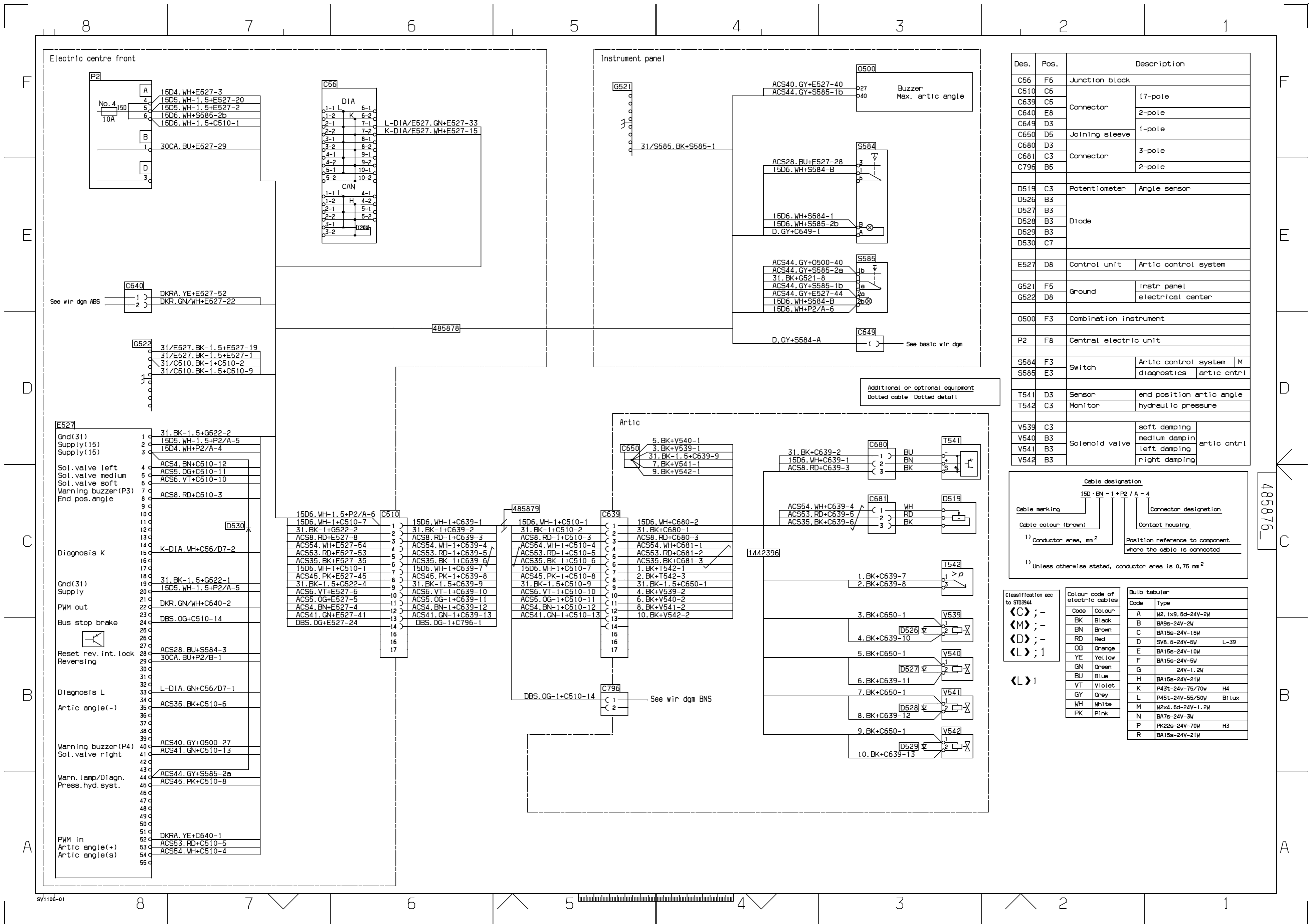

Des.	Pos.	Description	
C56	F6	Junction block	
C510	C6	Connector	17-pole
C639	C5		2-pole
C640	E8	Joining sleeve	1-pole
C649	D3		3-pole
C650	D5	Connector	2-pole
C680	D3		3-pole
C681	C3	Potentiometer	Angle sensor
C796	B5		Diode
D519	C3	Control unit	Artic control system
D526	B3		Diode
D527	B3	Diode	Diode
D528	B3		Diode
D529	B3	Control unit	Artic control system
D530	C7		Control unit
E527	D8	Control unit	Artic control system
G521	F5	Ground	instr panel
G522	D8	Ground	electrical center
O500	F3	Combination instrument	
P2	F8	Central electric unit	
S584	F3	Switch	Artic control system   M
S585	E3	Switch	diagnostics   artic cntrl
T541	D3	Sensor	end position artic angle
T542	C3	Monitor	hydraulic pressure
V539	C3	Solenoid valve	soft damping   artic cntrl
V540	B3	Solenoid valve	medium dampin
V541	B3	Solenoid valve	left damping
V542	B3	Solenoid valve	right damping

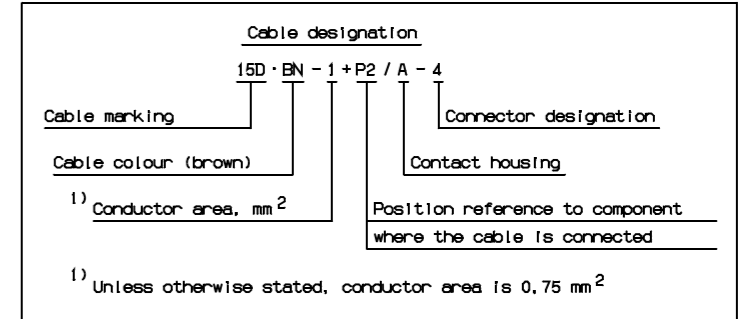

Classification acc to ST03944		Colour code of electric cables		Bulb tabular	
Code	Colour	Code	Colour	Code	Type
<C>; -	BK	Black	A	W2, 1x9, 5d-24V-2W	
<M>; -	BN	Brown	B	BA9s-24V-2W	
<D>; -	RD	Red	C	BA15s-24V-15W	
<L>; 1	OG	Orange	D	SV8, 5-24V-5W	L-39
	YE	Yellow	E	BA15s-24V-10W	
	GN	Green	F	BA15s-24V-5W	
	BU	Blue	G	24V-1,2W	
	VT	Violet	H	BA15s-24V-21W	
	GY	Grey	K	P43t-24V-75/70W	H4
	WH	White	L	P45t-24V-55/50W	B1lux
	PK	Pink	M	W2x4, 6d-24V-1,2W	
			N	BA7s-24V-3W	
			P	PK22s-24V-70W	H3
			R	BA15s-24V-21W	

485876