



16:54-36

Edition 1

- Slitageindikator för skivbroms**
- Wear indicator for disc brakes**
- Verschleißindikator für Scheibenbremse**
- Slijtage-indicator voor schijfrem**
- Indicateur d'usure de frein à disque**
- Indicador de desgaste de frenos de disco**
- Indicator de desgaste dos freios a disco**
- Indicatore usura freni a disco**
- Levyjarrun kulumisenilmaisín**
- Wskaźnik zużycia hamulca tarczowego**

8 7 6 5 4 3 2 1

F
E
D
C
B
A

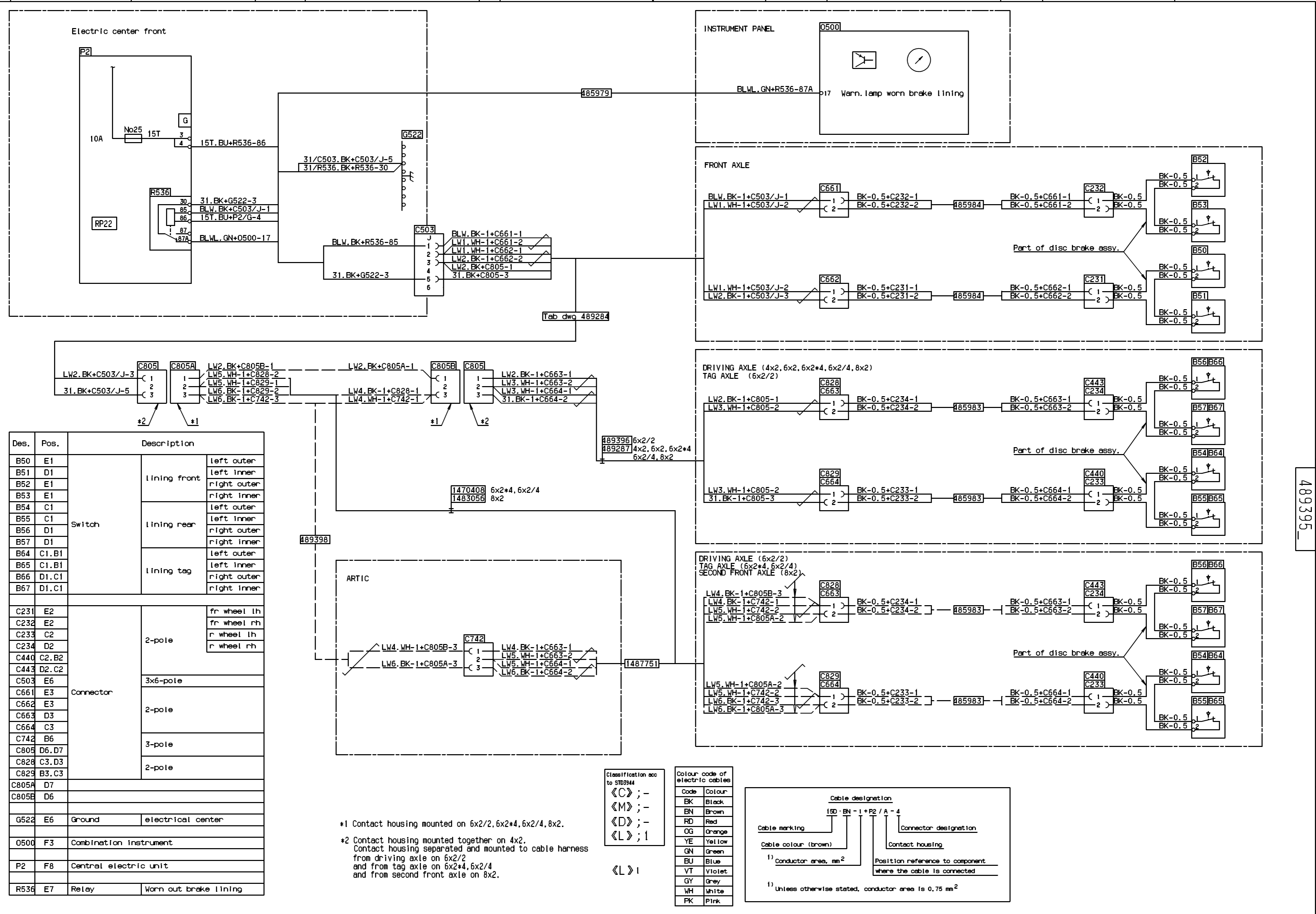

Des.	Pos.	Description
B50	E1	left outer
B51	D1	left inner
B52	E1	right outer
B53	E1	right inner
B54	C1	left outer
B55	C1	left inner
B56	D1	right outer
B57	D1	right inner
B64	C1.B1	left outer
B65	C1.B1	left inner
B66	D1.C1	right outer
B67	D1.C1	right inner
C231	E2	fr wheel lh
C232	E2	fr wheel rh
C233	C2	r wheel lh
C234	D2	r wheel rh
C440	C2.B2	
C443	D2.C2	
C503	E6	
C661	E3	
C662	E3	
C663	D3	
C664	C3	
C742	B6	
C805	D6.D7	
C828	C3.D3	
C829	B3.C3	
C805A	D7	
C805E	D6	
G522	E6	Ground electrical center
O500	F3	Combination Instrument
P2	F8	Central electric unit
R536	E7	Relay Worn out brake lining

*1 Contact housing mounted on 6x2/2, 6x2*4, 6x2/4, 8x2.
 *2 Contact housing mounted together on 4x2.
 Contact housing separated and mounted to cable harness from driving axle on 6x2/2 and from tag axle on 6x2*4, 6x2/4 and from second front axle on 8x2.

Classification acc to STB3944
 <C>; -
 <M>; -
 <D>; -
 <L>; 1

Code	Colour
BK	Black
BN	Brown
RD	Red
OG	Orange
YE	Yellow
GN	Green
BU	Blue
VT	Violet
GY	Grey
WH	White
PK	Pink

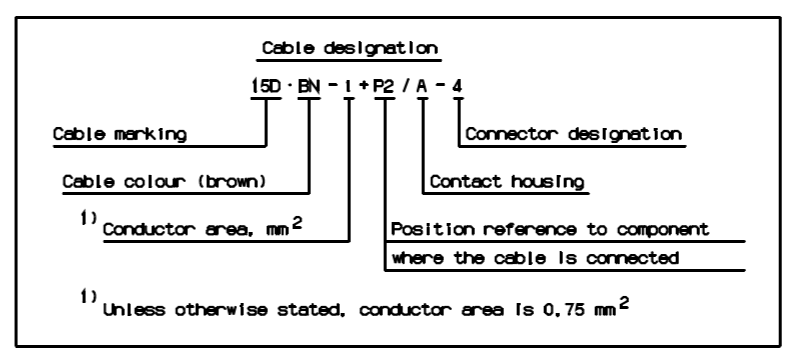

489395

cardiagn.com

8 7 6 5 4 3 2 1 A1