

**16:54-39**

Utgåva/Issue/Ausgabe/Utgave/Edición/Edition/Edizione/Painos 1

**ABS/TC**

Förbindningschema, Wiring Diagram, Verbindungsplan,  
Bedradingsschema, Diagrama de conexiones, Schéma de  
réalisation, Schema dei collegamenti, KytKentäkaavio, Dia-  
grama de conexões

**6x2/2**

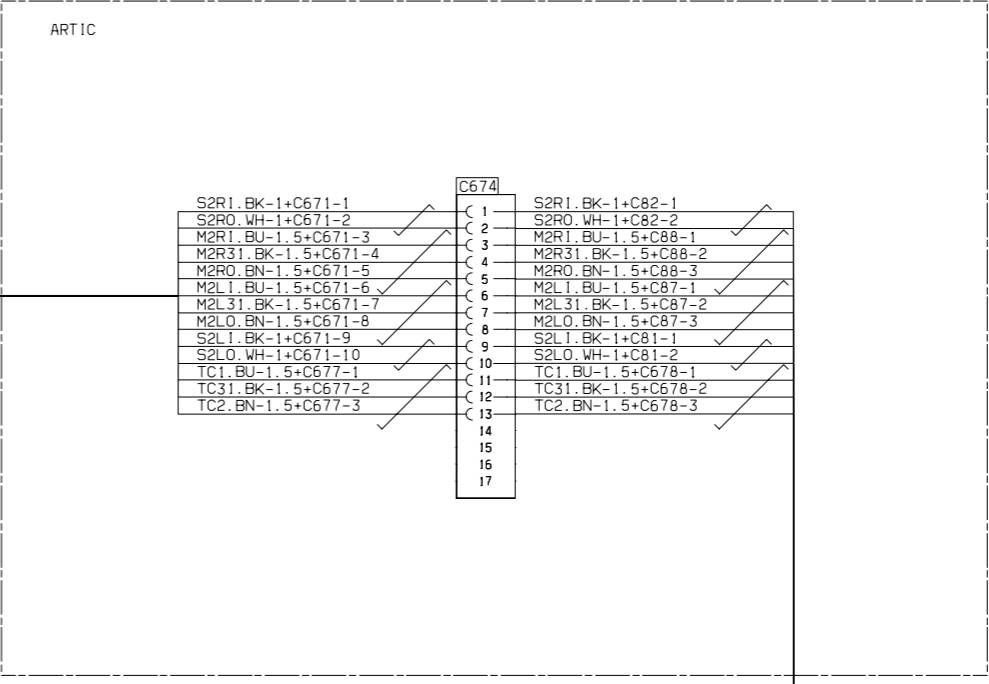
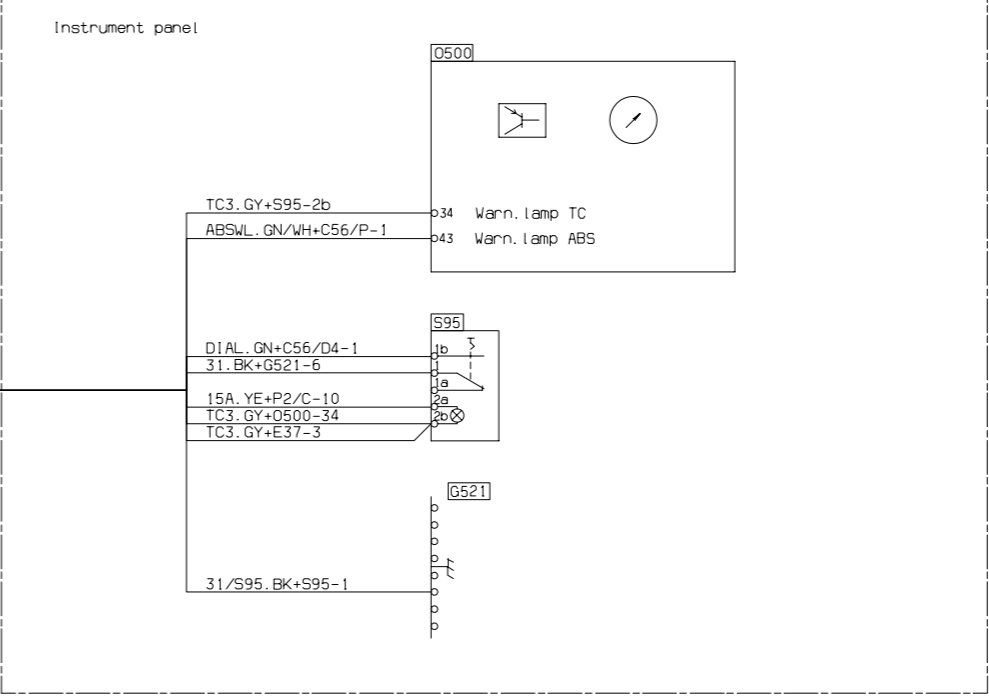
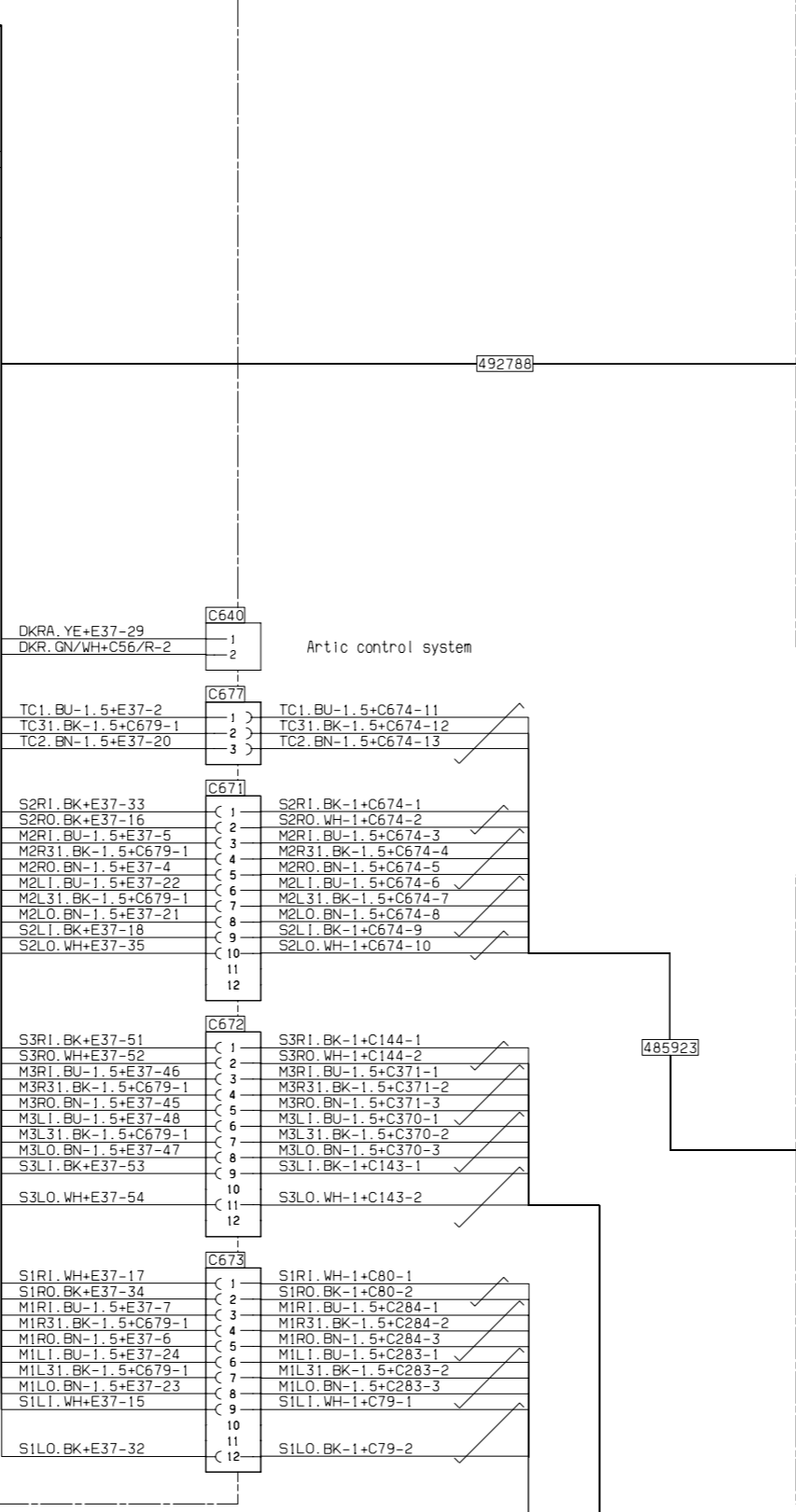
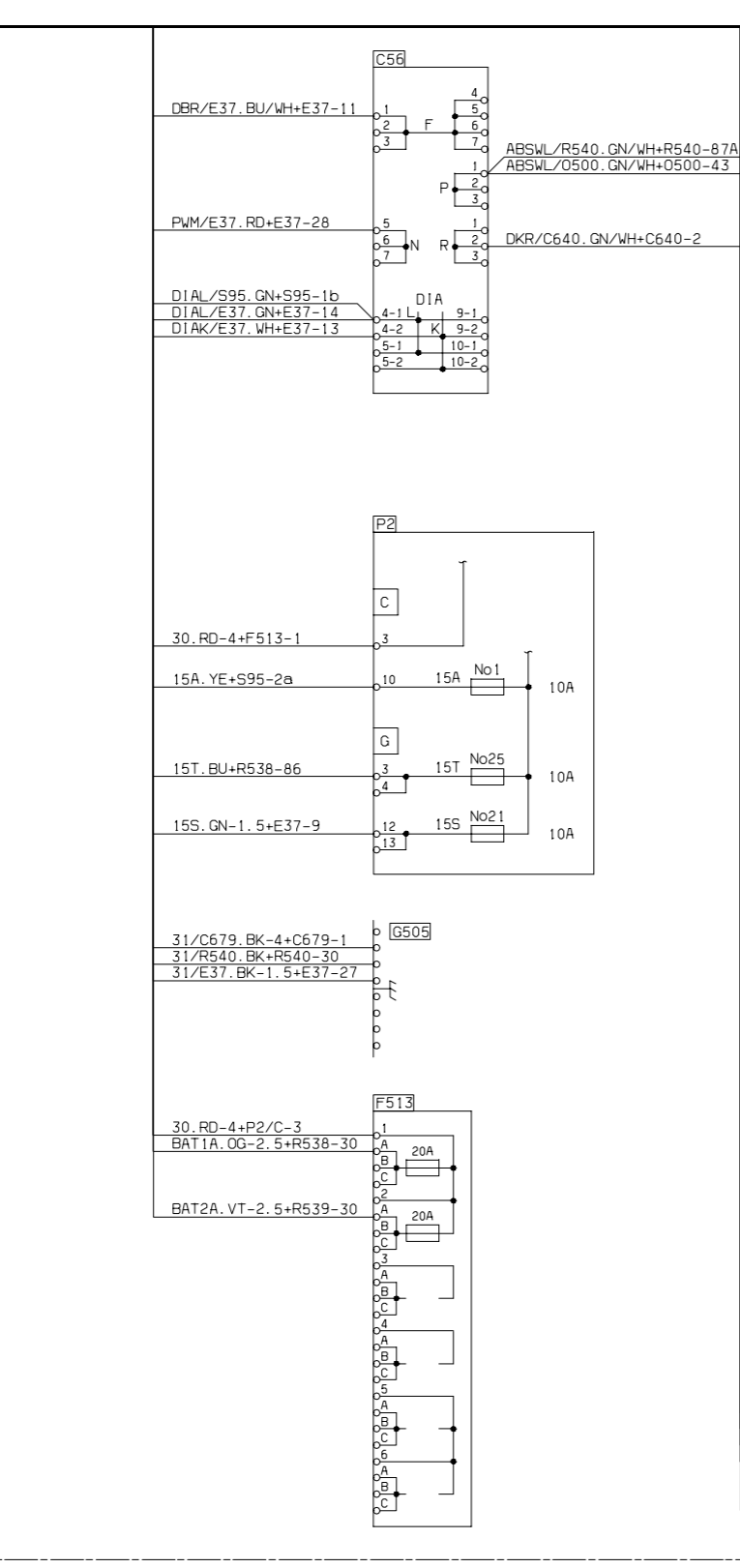
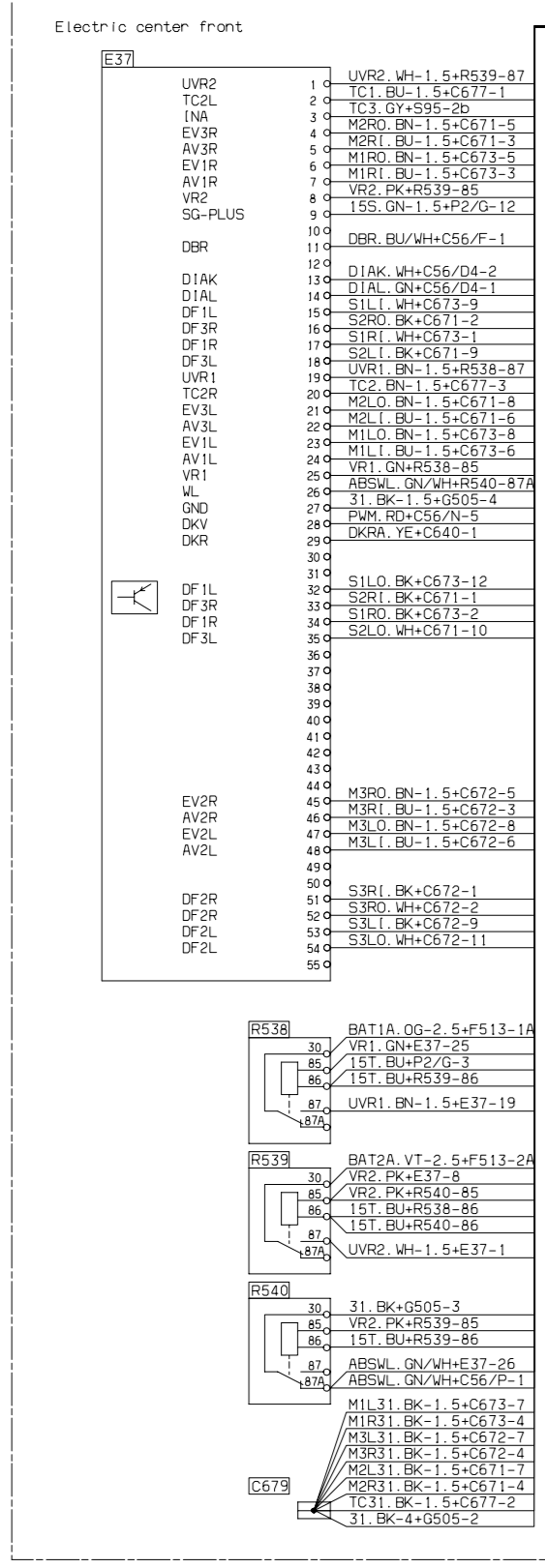

Des.	Pos.	Description	
C56	F6	Junction block	
C79	A8	2-pole	
C80	B8		
C81	A3		
C82	B3		
C87	B3		
C88	B3		
C143	A5		2-pole
C144	B5		
C284	B8	3-pole	
C370	B5		
C371	B5		
C640	E5	2-pole	
C671	D5		
C672	D5	12-pole	
C673	C5		
C674	D3	17-pole	
C677	E5		
C678	A3	3-pole	
C679	C8		
C679	C8	Joining sleeve 1-pole	
E37	F8	Control unit ABS	
F513	D6	Fuse holder 6-pole	
G505	D6	Ground electrical center	
G521	E3	instr panel	
O500	F3	Combination instrument	
P2	E6	Central electric unit	
R538	D8	Relay ABS	
R539	D8		
R540	D8		
S95	F3	Switch diagnostics	
T11	A7	Sensor	
T12	B7		front axle right
T13	A2		left
T14	B2		right
T28	A4	second axle left	
T30	B4	right	
V3	B7	Modulat valve	
V4	B7		front axle left
V5	B2	second axle left	
V6	B2		right
V46	B4	third axle left	
V47	B4		right
V81	A2	Solenoid valve TC	

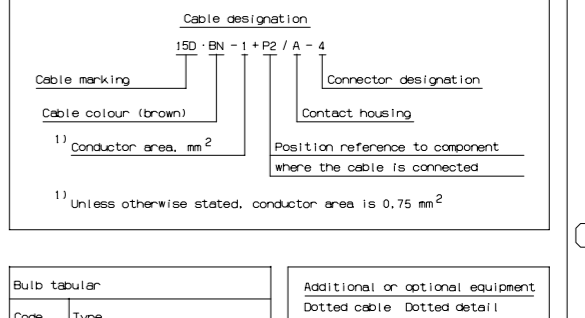

Code	Type
A	W2, 1x9, 50-24V-2W
B	B09s-24V-2W
C	BA15s-24V-15W
D	SV8, 5-24V-5W L=39
E	BA15s-24V-10W
F	BA15s-24V-5W
G	24V-1, 2W
H	BA15s-24V-21W
K	P43t-24V-75/70W H4
L	P45t-24V-55/50W BI lux
M	W2x, 6d-24V-1, 2W
N	BA7s-24V-3W
P	PK22s-24V-70W H3
R	BA15s-24V-21W

Code	Colour
BK	Black
BN	Brown
RD	Red
OG	Orange
YE	Yellow
GN	Green
BU	Blue
VT	Violet
GY	Grey
WH	White
PK	Pink

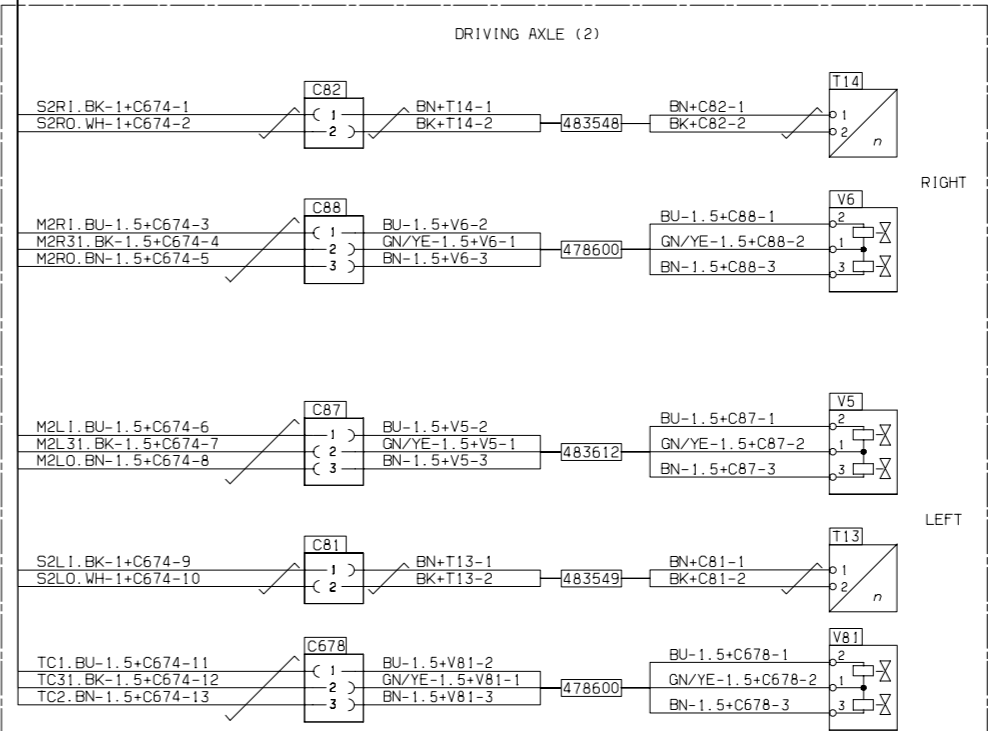
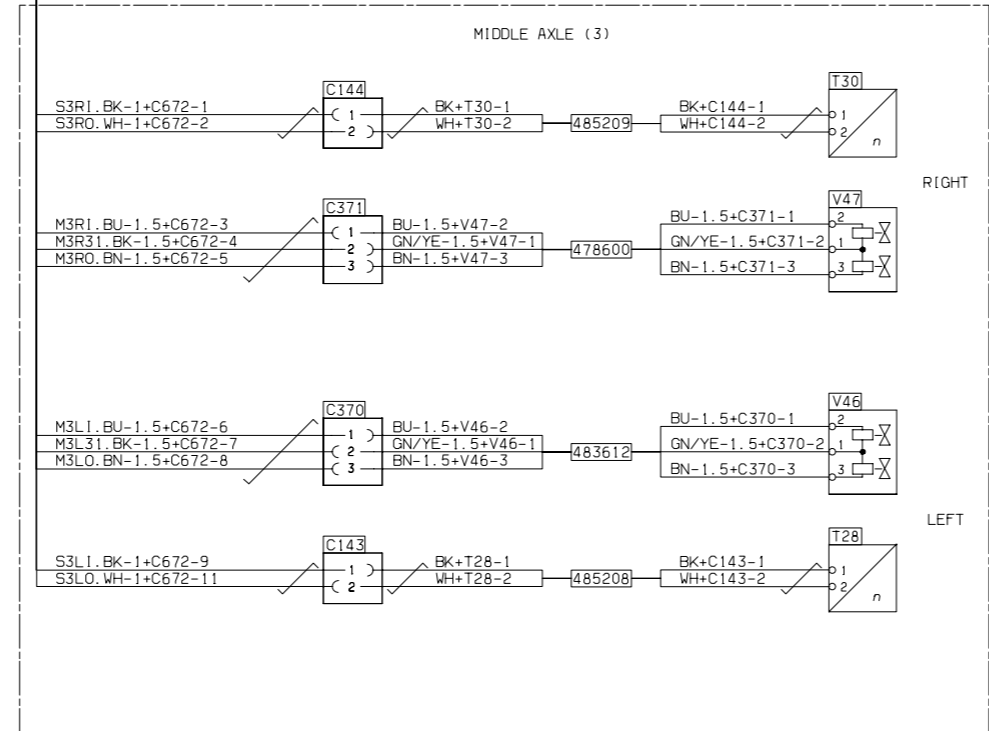
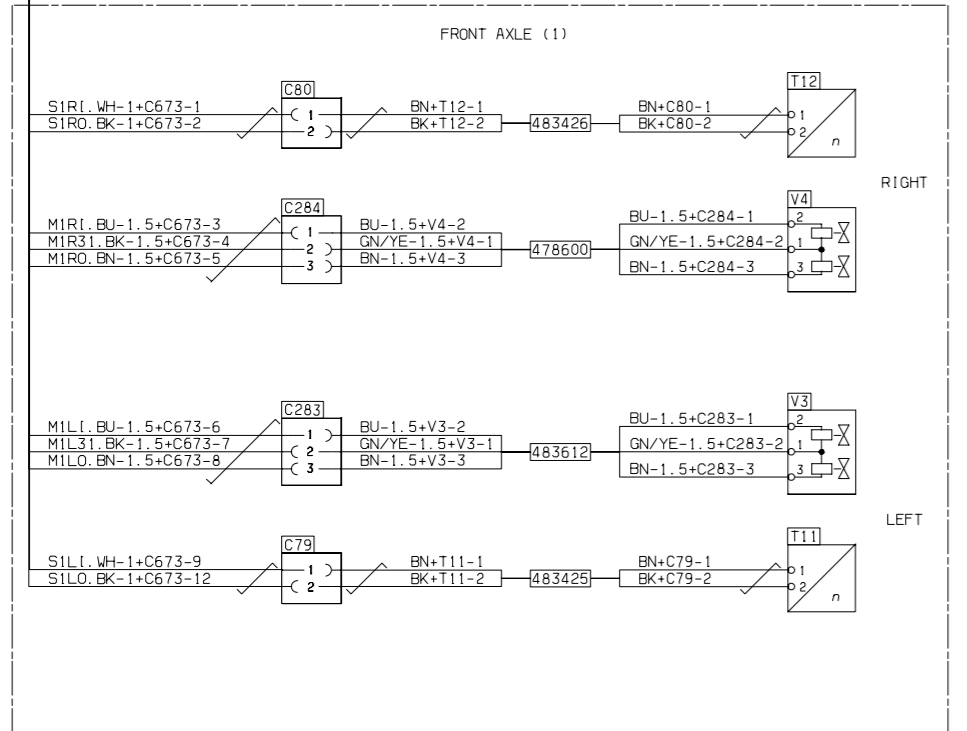

114730