

SCANIA

16:54-56

Edition 1

Nödstopp

Emergency Stop

Notstopp

Noodstop

Arrêt d'urgence

Parada de emergencia

Parada (Paragem) de emergência

Fermata di emergenza

Hätäpysäytin

**Förbindningschema, Wiring Diagram, Verbindungsplan,
Bedradingsschema, Schéma de réalisation, Diagrama de
conexiones, Diagrama de conexões, Schema dei collega-
menti, KytKentäkaavio**

K/L

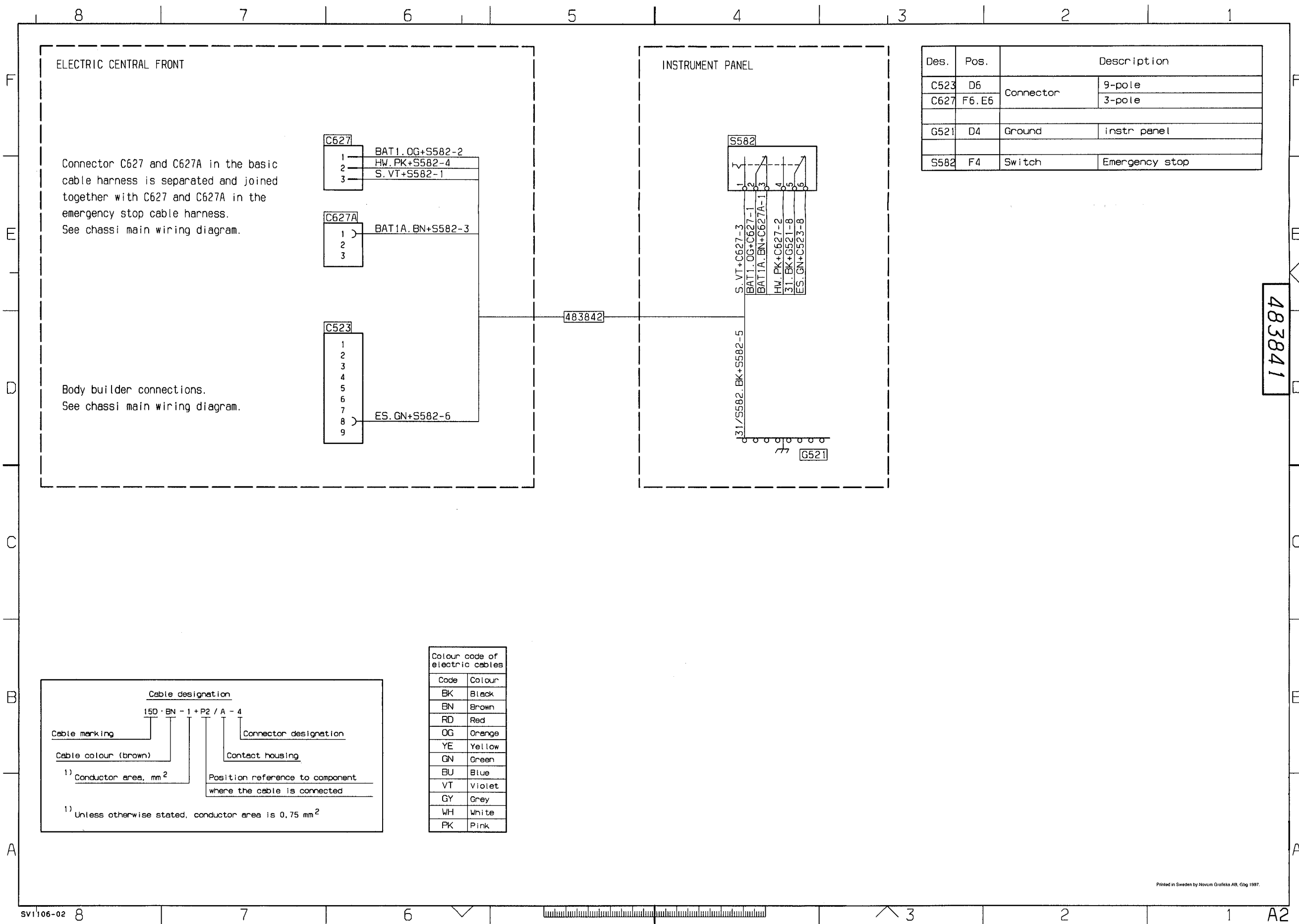

ELECTRIC CENTRAL FRONT

Connector C627 and C627A in the basic cable harness is separated and joined together with C627 and C627A in the emergency stop cable harness. See chassi main wiring diagram.

Body builder connections. See chassi main wiring diagram.

INSTRUMENT PANEL

Des.	Pos.	Description	
C523	D6	Connector	9-pole
C627	F6. E6		3-pole
G521	D4	Ground	instr panel
S582	F4	Switch	Emergency stop

Colour code of electric cables

Code	Colour
BK	Black
BN	Brown
RD	Red
OG	Orange
YE	Yellow
GN	Green
BU	Blue
VT	Violet
GY	Grey
WH	White
PK	Pink

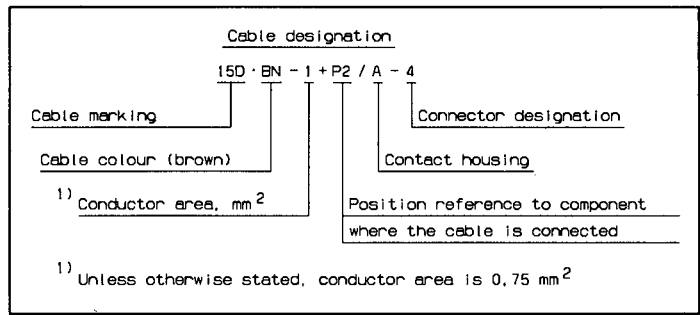

483841