

## Blocking of unintentional starter motor engagement

### Background

We have had reports of damage to starter gear. The damage has been caused by the starter ring gear, see illustration below. We have also had reports of damage to starter ring gear.

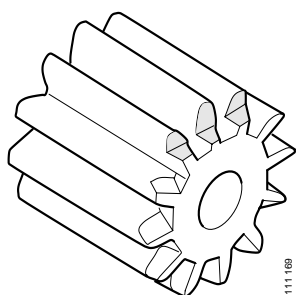

*Damaged starter gear.*

The cause of these problems is that the starter motor is engaged while the engine is running. One reason for this may be that the driver tries to start the engine when it is already running. Another reason may be that the driver turns the ignition key to starting position while driving.

The most frequent symptom is a starting problem; only a clicking sound is heard when ignition key is turned.

### Action

The problem is solved by fitting a protective circuit in the central electric unit. The circuit prevents the starter motor from being engaged while the engine is running.

The protective circuit has been introduced in production as from October 1998 and as from the following chassis Nos:

Scania Södertälje	1 243 900
Scania Zwolle	4 400 140
Scania Angers	9 036 062

## Work description

1. Disconnect vehicle power supply by disconnecting battery negative lead or by switching off main power switch.
2. Remove cover below central electric unit. Open central electric unit.
3. Insert cable harness 1 422 862 according to wiring diagram.
4. If required, detach R2 from mounting plate or remove the nearest control unit. If vehicle is fitted with VPS (Vehicle Protection System), remove VPS battery. Refer to illustration above for component location.
5. Detach cable 50X.VT-1,5 from relay R2-86. R2 is fitted to underside of mounting plate, below central electric unit. Remove existing cable terminal from cable by cutting. Strip cable as required and crimp on cable terminal 815 699. Insert cable terminal into new connector marked C 5001.
6. Detach cable from R2-87 (50.Wh-4). Fit cable with ring terminal 50.WH-1 in cable harness 1 422 862 to R2-87. Position new ring terminal lowermost and refit detached cables on top.

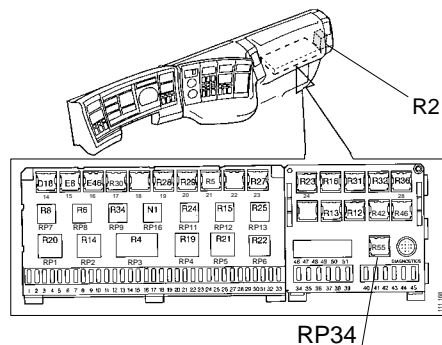

**Note!** Disengage connector lock before removing cable terminal.

11. Remove existing cable terminal from cable by cutting.
12. Strip cable as required and crimp on cable terminal 815 663 together with cable 61.YE.1,5 of cable harness. Fit two cables in the same cable terminal.

**Note!** The new cable may be fitted outside the rubber insulation. Try to insert it into the existing contact insulation, if possible.

7. Connect cable harness cable marked 50X.BU-1,5 to relay R2-86.
8. Connect new part of connector C 5001 with existing part in cable harness.
9. Attach new cable harness to existing cable harness. Tie up cables towards central electric unit, where any excess cable can be placed.
10. Remove cable terminal P2/F-3 from central electric unit using tool 588 198.

13. Refit cable terminal in position P2/F-3.  
Engage connector lock.
14. Insert connector for R33 in relay position  
RP34. Insert relay in relay holder.

**Note!** Relay R33 for starter blocking must always be fitted in relay position RP34. If RP34 is occupied by other relay, move this to other suitable position.

15. Attach diode D33 to existing cable harness by means of cable tie.
16. Reconnect vehicle power supply.
17. Check function as follows:
  - Start engine: Result: Normal starting possible.
  - Switch off engine and remove relay R33.
  - Try to start engine. Result: Starting not possible.
18. Close central electric unit and refit any detached control units and (if fitted) the VPS battery. Refit covers below central electric unit.

## Parts

Designation	Part No.	Qty
Cable harness	1 422 862	1
Cable terminal	815 699	1
Cable terminal	815 663	1
Relay	1 391 322	1
Tool	588 138	1
Cable tie		

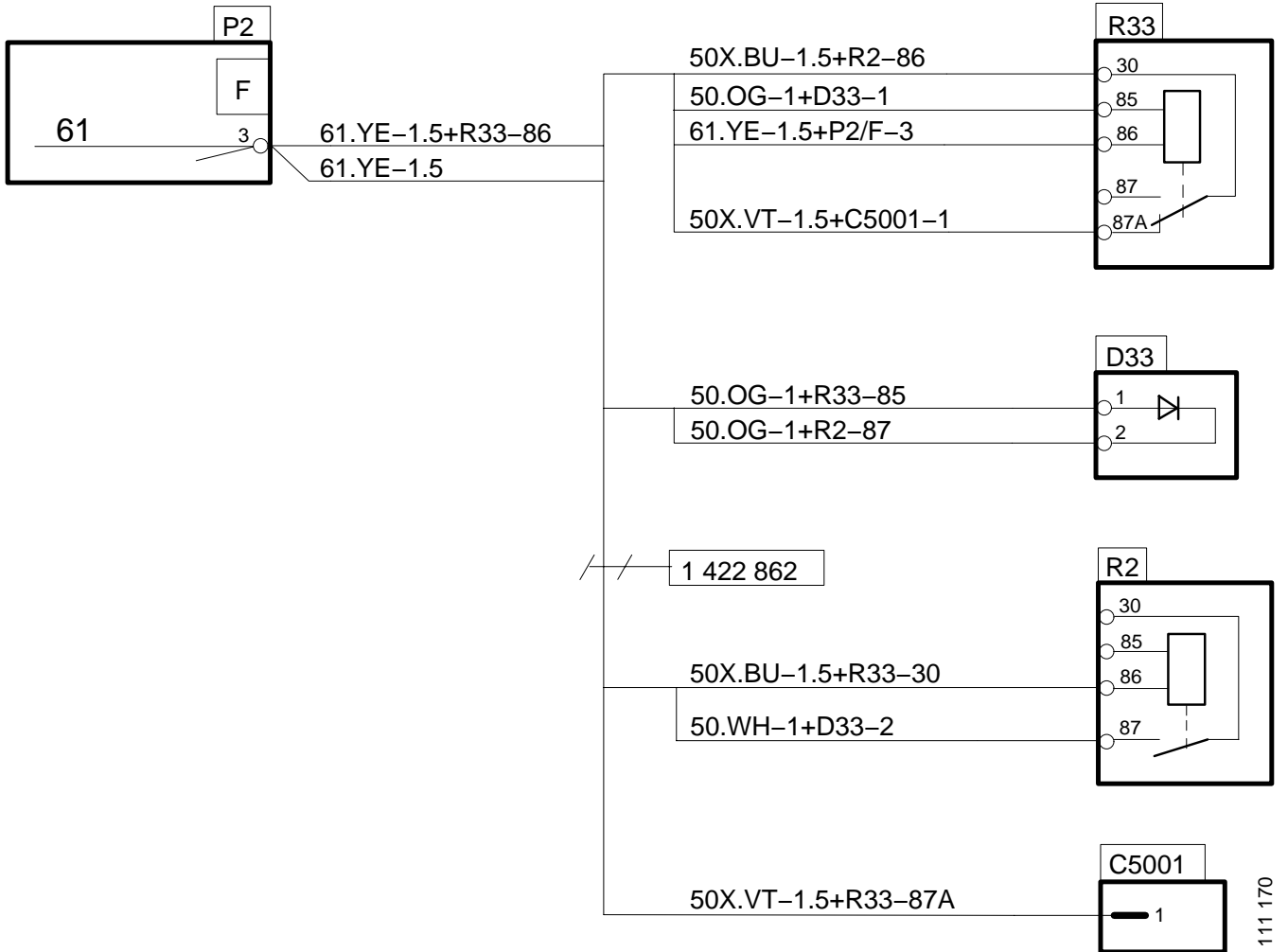

111 170