

Earth fault which interferes with the temperature gauge

Applies to DC11 and DSC12.

Background

There have been incidences when the coolant temperature gauge has indicated an incorrect temperature. Inadequate earthing between the chassi and the engine is the cause. Currently earthing is achieved between two earth braids which are placed in the engine frame and side-covers.

Production solution

One of the earth braids 1 378 852 is removed in production and replaced by an earth cable. One of the earth cable ends is fitted to an already existing hole in the frame and the other end is fitted to the starter motor, see illustration.

This has been remedied in production from the chassi numbers below:

Scania Södertälje	1 246 798
Scania Zwolle	4 405 372
Scania Angers	9 038 858
Scania Latin America	

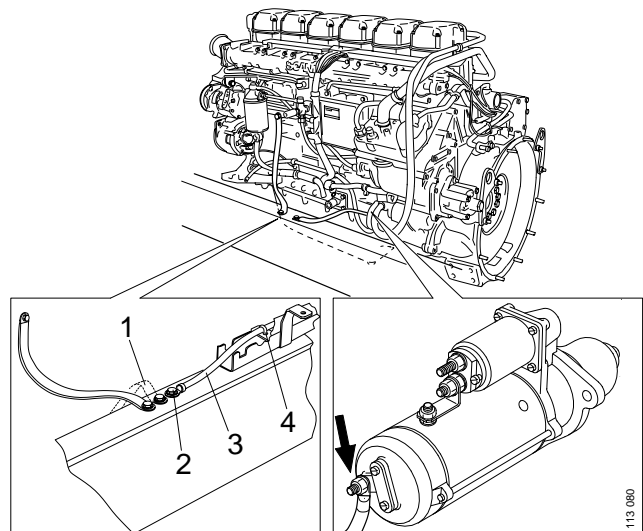

- 1 *Outgoing earth braid 1 378 852*
- 2 *Screw 813 005*
- 3 *Earth cable 1 378 324*
- 4 *Strap 815 363*

Service solution

Move the rear side cover earth braid to a suitable casting protrusion on the cylinder block. Scrape off the colour on the cylinder block before fitting the earth braid to the new earth point.

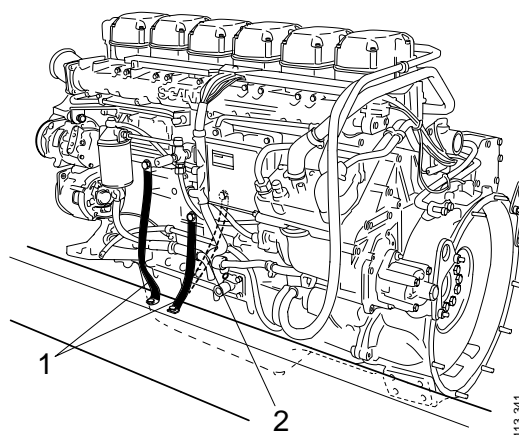

- 1 The old production solution.
2 After the service solution.

Parts

Description	Outgoing P/N	New P/N
Earth braid	1 378 852	-
Screw	-	813 005
Earth cable	-	1 378 324
Strap	-	815 363