

SCANIA

18:02-01

Issue 2 en

Seat

Description of operation and work description

Fault diagnosis

Type A, Luxury and Medium

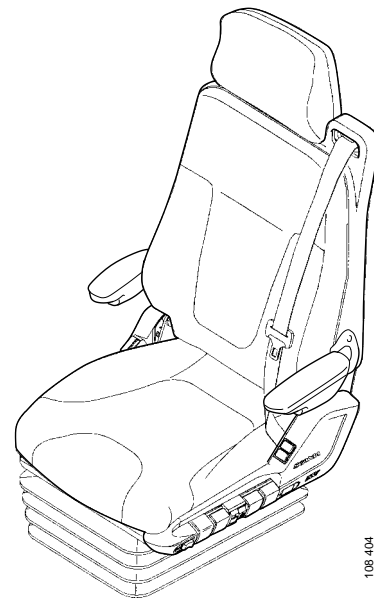
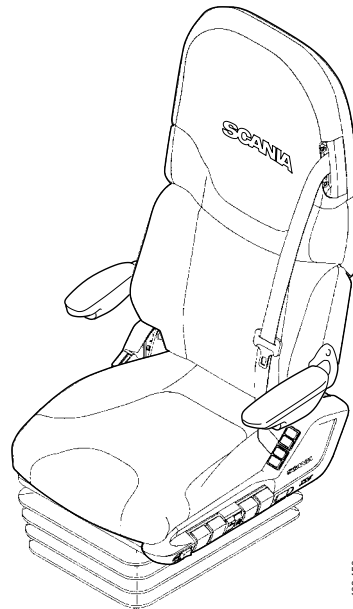

Contents

Description of operation	Luxury A.....	6
	Medium A.....	7
	Part numbers and serial numbers.....	8
	Air and electrics.....	9
	The belt locks when the backrest is lowered	14
Fault diagnosis	Fault codes	15
	Check this first	16
	Versions of the control unit.....	17
	Fault codes	17
	Fault diagnosis with a multimeter.....	27
	Starter key positions	29
	Colour designations on the cables	29
	Potentiometer	30
	Solenoid valve.....	32
	Control unit.....	34
	Switch for the heater pads	36
	Heater pad.....	38
	Contact for the seat's electrical connections.....	40
	Belt switch	42
	Button for adjusting height	43
	Buckle	46
	Inertia reel.....	47
	Sensor in the seat squab.....	48

Work description	Exploded views	50
	Luxury A	50
	Medium A.....	52
	Spot repairs.....	54
	If the shock absorber becomes rigid.....	54
	If the height adjustment malfunctions	55
	If the seat rattles	57
	Repair kit for the air hoses	58
	Removal and refitting	59
	Warnings to be observed when working on the seat	59
	Changing the seat	60
	Seat squab.....	62
	Seat squab with seat-depth setting	62
	Slider	62
	Seat squab without a seat-depth setting ...	63
	Seat squab upholstery	64
	Heater pad in the seat squab.....	65
	Buttons and controls	66
	Control valve for the side supports and lumbar support	66
	Buttons	66
	Button for adjusting height	67
	Switch for the heater pad	67
	Casing on the lower part of the seat	68
	Side casing with control buttons	68
	Side casing without control buttons	68
	Front casing.....	69
	Lower rear casing.....	69

Cont. on the next page

Backrest.....	70
Backrest cushion	70
Head restraint on Medium A	71
Armrest	71
Backrest casing on Luxury A.....	72
Backrest casing on Medium A.....	72
Ratchet segment for tilting Medium A	73
Backrest upholstery on Luxury A.....	74
Backrest upholstery on Medium A	75
Heater pad in the backrest.....	76
Air cushions for the lumbar support	76
Air cushions for the side supports in Luxury A.....	77
Upper air valve in Luxury A.....	78
Lower air valve in Luxury A.....	78
Valve for setting the backrest in Luxury A	79
Seat belt.....	81
Seat belt for Luxury A	81
Seat belt for Medium A	82
Seat belt and belt tightener for Luxury A	83
Seat belt and belt tightener for Medium A	86
Buckle	88
Belt switch in Luxury A.....	88
Seats for the US market	89
Shock absorber and cable.....	90
Shock absorber.....	90
Cable for setting the shock absorber.....	91
Gas spring and cable	92
Gas spring in Medium A.....	92
Cable for the gas spring in Medium A.....	93
Air spring.....	94
Electronic parts.....	95
Control unit.....	95
Solenoid valve.....	97
Potentiometer	98

Description of operation

The "Description of operation" contains the following:

- a description of buttons, controls, part numbers and serial numbers on the Luxury A and Medium A seats;
- the location of electrical contacts;
- compressed air diagrams;
- a description of how the backrest microswitch raises and lowers the backrest.

Seat

Luxury A

Luxury A is equipped with air suspension and a belt tightener (the latter is optional).

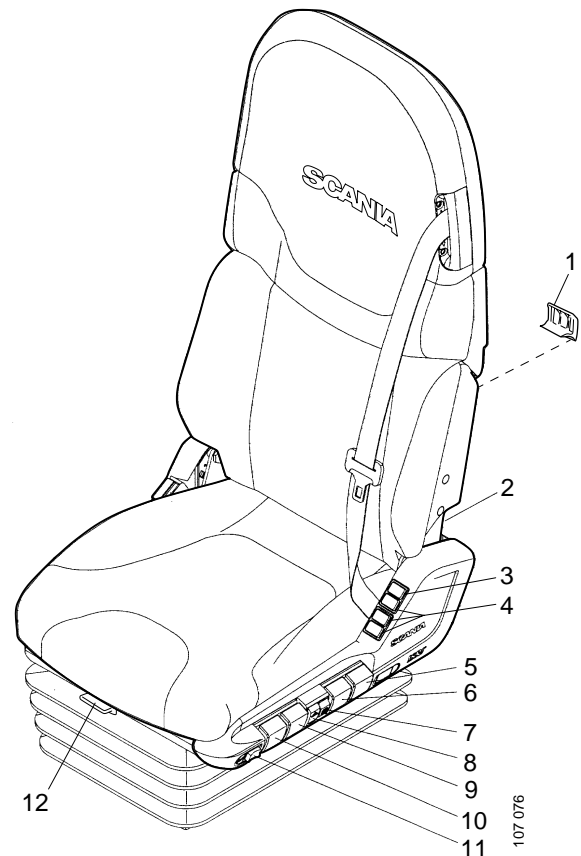

Luxury A

- | | |
|---|--|
| <ul style="list-style-type: none"> 1 <i>Handle for raising and lowering the upper part of the backrest.</i> 2 <i>Service handle. For emergency use if there is no air pressure. Push the handle to the side to adjust the backrest.</i> 3 <i>Side support. For adjusting the two air cushions.</i> 4 <i>Lumbar support. For adjusting the three air cushions.</i> 5 <i>Shock absorber adjustment.</i> 6 <i>For adjusting the upper and lower parts of the backrest.</i> | <ul style="list-style-type: none"> 7 <i>Rapid lowering function.</i> 8 <i>Height adjustment.</i> 9 <i>For tilting the seat support.</i> 10 <i>For adjusting the length of the seat squab. It adjusts in steps, forwards and backwards (up to March 1998).</i> 11 <i>Heater pad</i> 12 <i>For adjusting the length of the seat squab. It adjusts in steps, forwards and backwards (as from April 1998).</i> |
|---|--|

Medium A

Medium A is available with or without air suspension, and with or without a belt tightener.

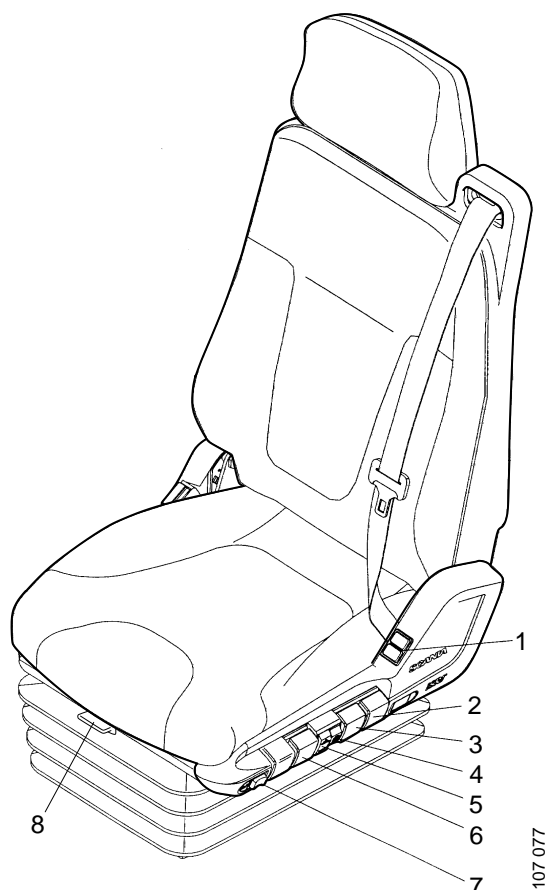

Medium A with air suspension

- 1 Lumbar support. For adjusting the two air cushions.
- 2 Shock absorber adjustment.
- 3 For adjusting the backrest in steps.
- 4 Rapid lowering function.
- 5 Height adjustment.
- 6 For tilting the seat squab.
- 7 For heating the squabs.
- 8 For adjusting the length of the seat squab. It adjusts in steps, forwards and backwards (as from April 1998).



Medium A without air suspension (gas spring)

- 1 Mechanical adjustment of the lumbar support.
- 2 For adjusting the backrest in steps.
- 3 Height adjustment.
- 4 For tilting the seat squab.
- 5 For heating the squabs.

Part numbers and serial numbers

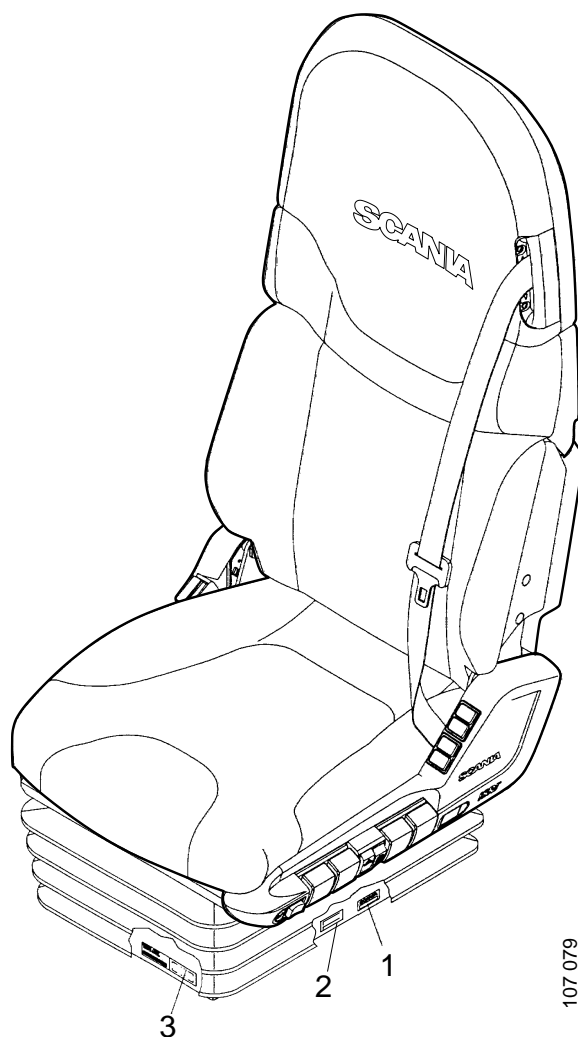

The following numbers apply up to and including March 1998:

- 1 Scania part number*
- 2 -*
- 3 Seat serial number*

The following numbers apply as of April 1998:

- 1 Part number of the backrest*
- 2 Part number of the shock absorber unit*
- 3 Seat serial number*

Air and electrics

Input, output and contacts

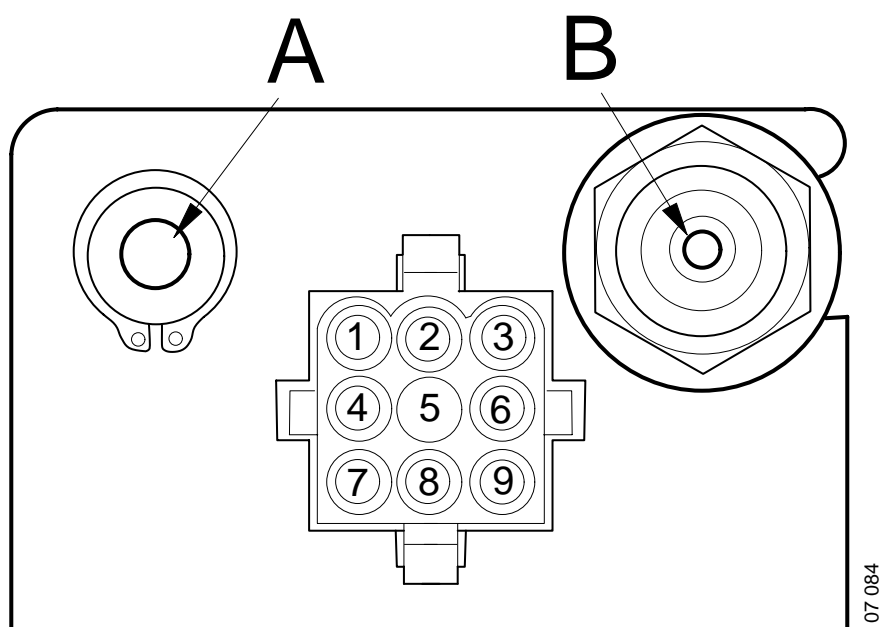

A Output (grey)

B Input (black)

- 1 30 Battery, 24 volts (red)*
- 2 15 Ignition (black)*
- 3 61 Engine running, heater pad in the seat squab (red/white)*
- 4 ISO-K Seat diagnostics system (white/yellow)*
- 5 Empty*
- 6 31 Earth (brown)*
- 7 Warning lamp and safety belt (brown/blue)*
- 8 Belt tightener (orange)*
- 9 Belt tightener (black)*

Compressed air diagram for Luxury A

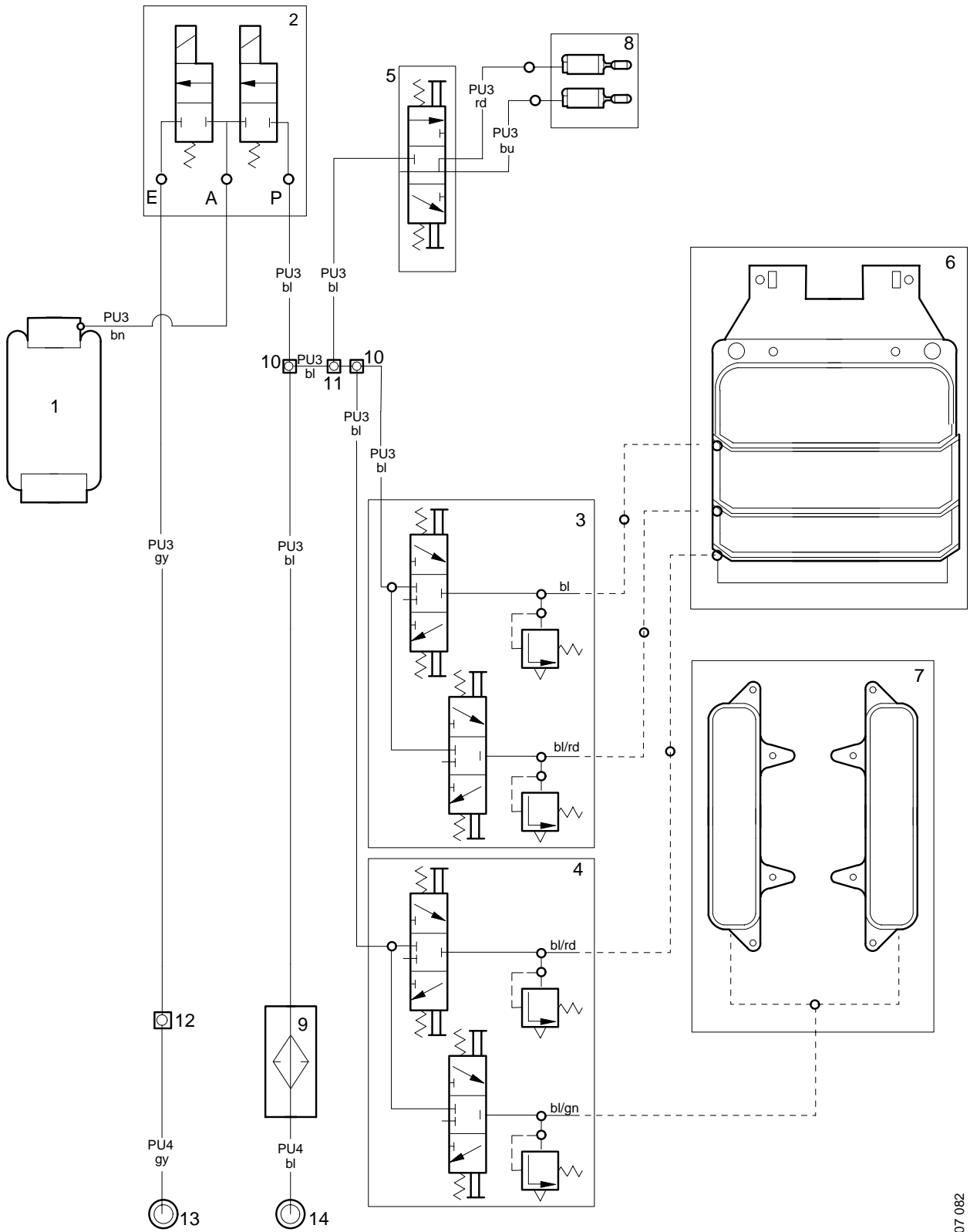

107 082

- 1 *Air spring*
- 2 *Solenoid valve*
- 3 *Control valve*
- 4 *Control valve*
- 5 *Guide valve*
- 6 *Air cushions for the lumbar support*
- 7 *Air cushions for the side supports*
- 8 *Air valves for tilting the backrest*
- 9 *Air filter*
- 10 *Distribution device*
- 11 *Distribution device*
- 12 *Distribution device*
- 13 *Hose connection*
- 14 *Hose connection*

Compressed air diagram for Medium A

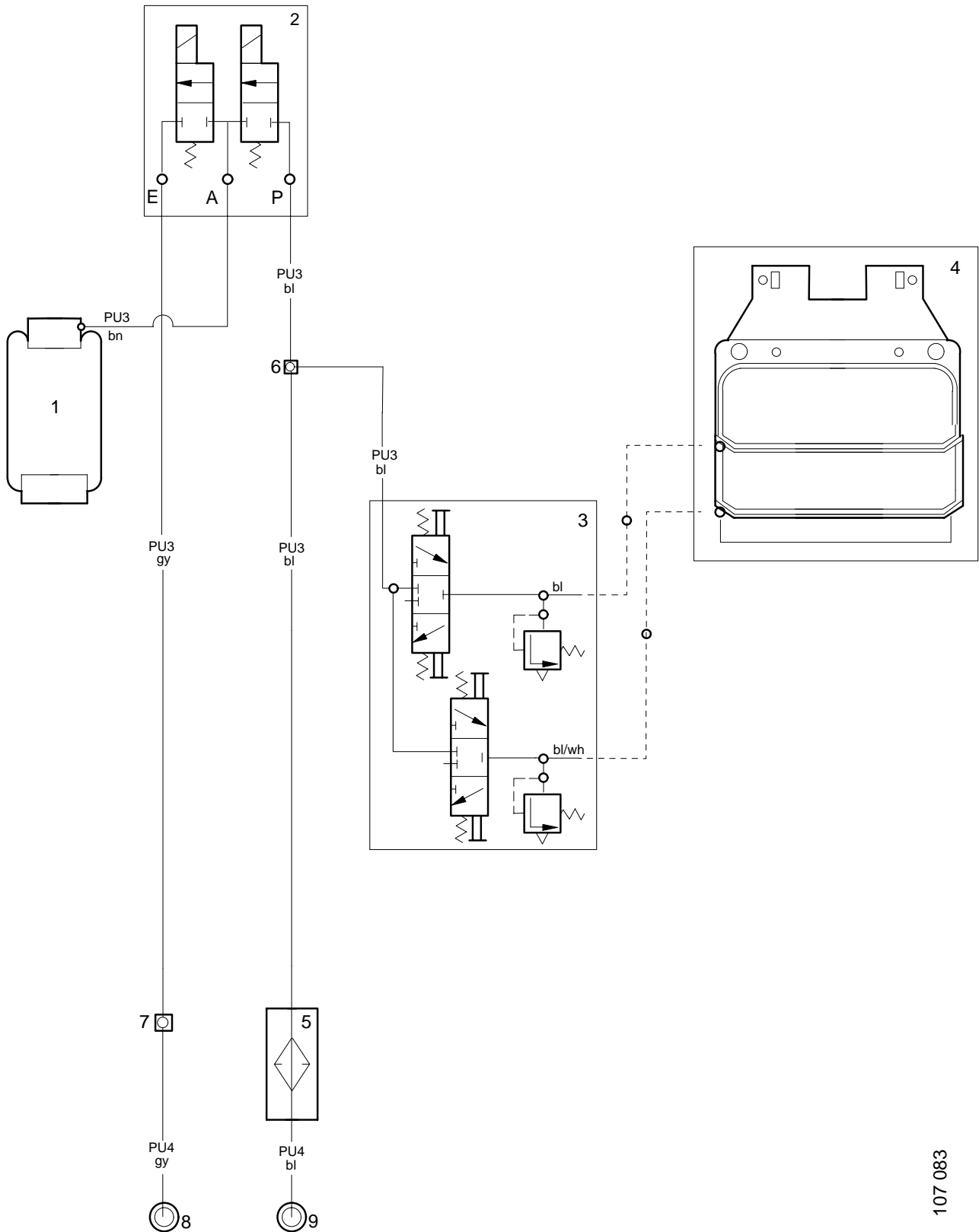

107 083

- 1 *Air spring*
- 2 *Solenoid valve*
- 3 *Control valve*
- 4 *Air cushion for the lumbar support*
- 5 *Air filter*
- 6 *Distribution device*
- 7 *Distribution device*
- 8 *Hose connection*
- 9 *Hose connection*

The belt locks when the backrest is lowered

Microswitch or button

Seats with a microswitch have part numbers:

- 1 345 783-1 345 786

In this type of seat, the belt is reeled into the seat and locks whenever the backrest is lowered. The backrest is raised with the handle which supplies current to the inertia reel via a microswitch so that the belt can operate freely again (see the illustration).

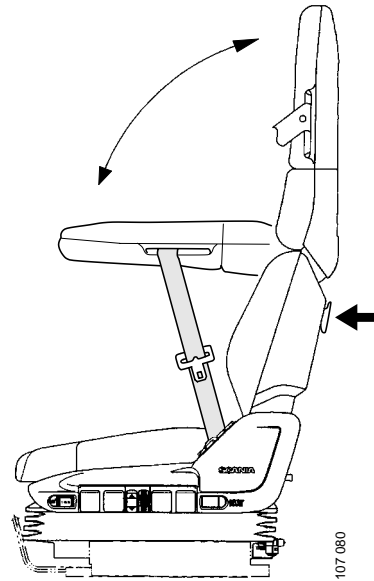

If the seat is not connected to 24 V, the handle microswitch will not function and the belt, which is locked, will prevent the backrest from being raised. Connect 24 V to pins 1 and 2, and earth pin 6.

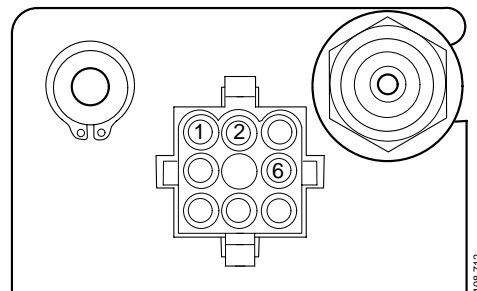

Seats with a button have part numbers:

- 1 404 605-1 404 608

In this later version of seat, the belt remains slack when the backrest is lowered. The backrest is raised with the handle. The handle microswitch has been replaced by a button that prevents the belt from rewinding.

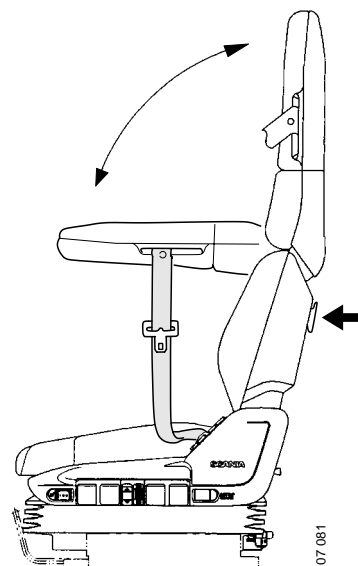

Fault diagnosis

The section on fault diagnosis contains:

- fault codes;
- instructions on how to perform a fault diagnosis on the seat components using a multimeter.

Seat, type A

Check this first

Some faults can be rectified without having to read the fault codes. This reduces the likelihood of having to replace a component that is functioning well. If the seat has any of the following faults, carry out the checking procedure below:

Faults in the seat

- The seat does not adopt the automatic height setting.
- The seat sets the height itself.
- The seat cannot be raised from the lowest position.
- The seat cannot be lowered.

Checks exterior to the seat

- Check that the voltage to the wiring in the seat is $17V < U < 31V$.
- Check that the air pressure to the seat is 7-10 bar.
- Check that there is nothing in the cab preventing the seat from being raised or lowered.

Checks inside the seat

- Check that the air hoses are not leaking and that there are no folds in them.
- Check that the cable harness is not damaged.
- Check that the contacts are connected and that there are no signs of oxidation on the pins.

Versions of the control unit

There are two different versions of control unit, one of which is black and the other blue.

- The black version has part No. 1 377 511.
- The blue version has part No. 1 420 850.



fault codes;

When the power is switched on, the yellow lamp in the control unit lights up for five seconds.

When the power is switched off, the yellow lamp lights up for four seconds.













The control unit displays the fault code and repeats it every 16 seconds.

Checking the control unit

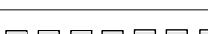
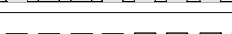
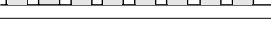
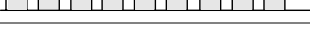
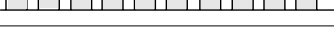
a	 5 seconds
b	 4 seconds

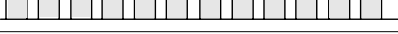
108 456

fault codes;

1	
2	
3	
4	
5	
6	
7	
8	
9	
10	
11	
12	
13	
14	
15	
16	

108288

Fault code a

Fault

None.

Cause

Pre-operational check of the control unit functions.

Remarks

If the control unit is working normally, the yellow lamp will light up for five seconds when the power in the vehicle is switched on.

Remedial measure

None.

Fault code b

Fault

None.

Cause

Post-operational check of the control unit functions.

Remarks

If the control unit is working normally, the yellow lamp will light up for four seconds when the power in the vehicle is switched off.

Remedial measure

None.

Fault code 1**Fault**

None.

Cause

Reserved fault code. The seat has the old type of control unit or a faulty control unit.

Remarks

There are different versions of control unit.

Remedial measure

Replace the control unit.

Fault code 2**Fault**

With the black version of control unit, nothing is working except the heater pad.

With the blue version, the seat is working even though the supply voltage is too low.

Cause

The supply voltage is too low, less than 17 V.

Remedial measure

Look for a fault in the cable harness, the electrical connections for the seat and the control unit.

Fault code 3

Fault

With the black version of control unit, nothing is working except the heater pad.

With the blue version, the seat is working even though the supply voltage is too high.

Cause

The supply voltage is too high, in excess of 31 V.

Remedial measure

Look for a fault in the cable harness, the electrical connections for the seat and the control unit.

Fault code 4

Fault

The control unit is not reacting to the fact that air is escaping from the seat.

Cause

A fault in the solenoid valve output, hoses or cable harness.

Remedial measure

Look for a fault in the cable harness, the potentiometer or solenoid valve.

Fault code 5**Fault**

The control unit is not reacting to the fact that air is entering the seat.

Cause

The pressure of the air entering the solenoid valve is too low, or there is a fault in the cable harness.

Remedial measure

Look for a fault in the cable harness, the potentiometer or solenoid valve.

Fault code 6**Fault**

None.

Cause

Reserved fault code. The seat has the old type of control unit or a faulty control unit.

Remarks

There are different versions of control unit.

Remedial measure

Replace the control unit.

Fault code 7

Fault

Nothing is working except the heater pad.

Cause

One of the control unit parameters is faulty.

Remedial measure

Replace the control unit.

Fault code 8

Fault

The height adjustment function is not working.

Cause

Short circuit in the electrical connection of the solenoid valve.

Remedial measure

Look for a fault in the cable harness, solenoid valve or control unit.

Fault code 9**Fault**

The height adjustment function is not working.

Cause

Short circuit in the electrical connection of the solenoid valve.

Remedial measure

Look for a fault in the cable harness, solenoid valve or control unit.

Fault code 10**Fault**

The height adjustment function is not working.

Cause

Break in the solenoid valve input.

Remedial measure

Look for a fault in the solenoid valve or control unit.

Fault code 11

Fault

The seat cannot be lowered.

Cause

Break in the solenoid valve output.

Remedial measure

Look for a fault in the solenoid valve or control unit.

Fault code 12

Fault

None.

Cause

Reserved fault code. The seat has the old type of control unit or a faulty control unit.

Remarks

There are different versions of control unit.

Remedial measure

Replace the control unit.

Fault code 13**Fault**

None.

Cause

Reserved fault code. The seat has the old type of control unit or a faulty control unit.

Remarks

There are different versions of control unit.

Remedial measure

Replace the control unit.

Fault code 14**Fault**

None.

Cause

Reserved fault code. The seat has the old type of control unit or a faulty control unit.

Remarks

There are different versions of control unit.

Remedial measure

Replace the control unit.

Fault code 15

Fault

None.

Cause

Reserved fault code. The seat has the old type of control unit or a faulty control unit.

Remarks

There are different versions of control unit.

Remedial measure

Replace the control unit.

Fault code 16

Fault

The function for raising and lowering the seat automatically to a preset level is not working. The button for height adjustment is working.

Cause

Fault in the potentiometer or wiring.

Remarks

The lamp flashes continuously.

Remedial measure

Look for a fault in the cable harness, potentiometer or control unit.

Fault diagnosis with a multimeter

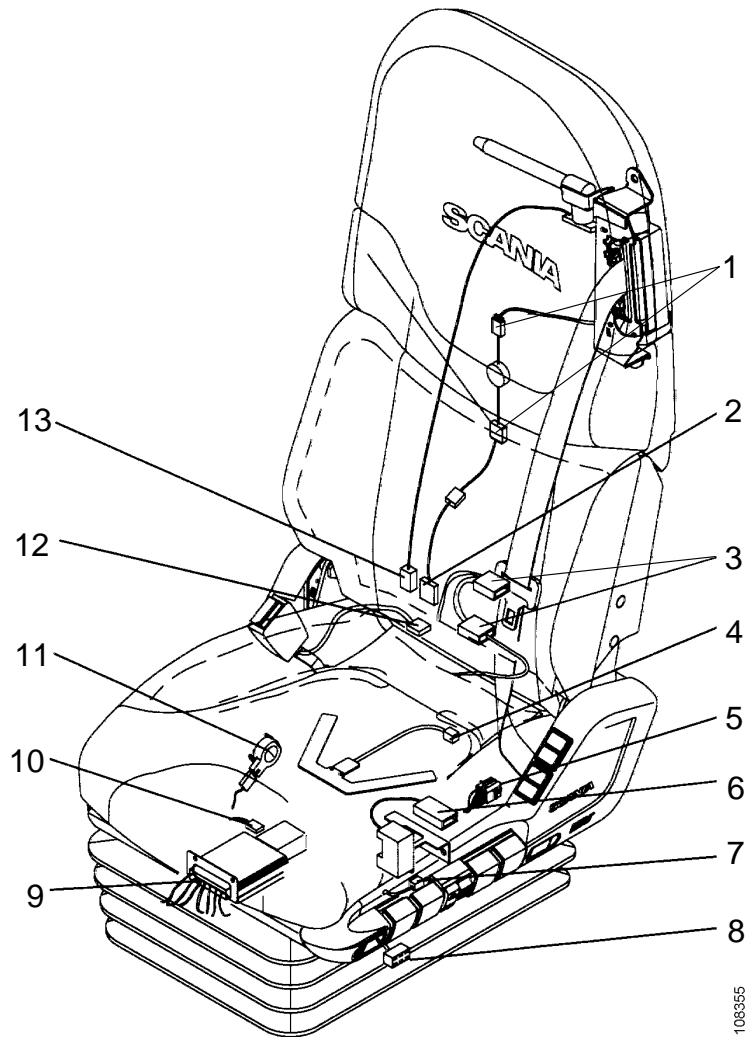

- | | | | |
|---|--|----|---|
| 1 | Contact for the varistor | 8 | Contact for the switch for the heater pad |
| 2 | Contact for the inertia reel | 9 | Contact for the control unit |
| 3 | Contact for the heater pads in the seat squab and backrest | 10 | Contact for the solenoid valve |
| 4 | Contact for the sensor in the seat squab | 11 | Contact for the potentiometer |
| 5 | Contact for the electrical connection of the seat | 12 | Contact for the buckle |
| 6 | Contact for the switch for the seat belt | 13 | Contact for the belt tightener |
| 7 | Contact for the height adjustment button | | |

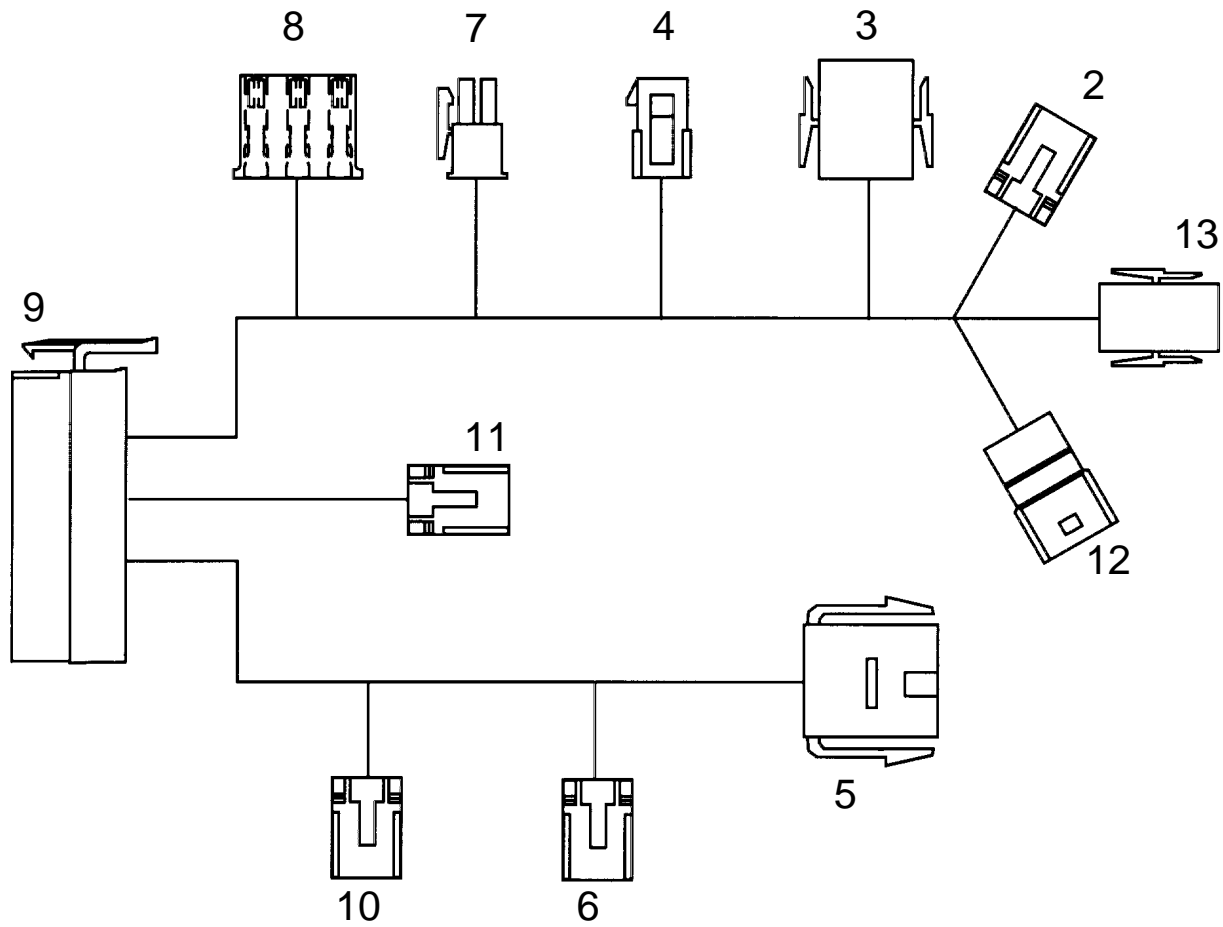

108401

- | | |
|---|---|
| <p>1 -</p> <p>2 Contact for the inertia reel</p> <p>3 Contact for the heater pads in the seat squab and backrest</p> <p>4 Contact for the sensor in the seat squab</p> <p>5 Contact for the electrical connection of the seat</p> <p>6 Contact for the switch for the seat belt</p> <p>7 Contact for the height adjustment button</p> | <p>8 Contact for the switch for the heater pad</p> <p>9 Contact for the control unit</p> <p>10 Contact for the solenoid valve</p> <p>11 Contact for the potentiometer</p> <p>12 Contact for the buckle</p> <p>13 Contact for the belt tightener</p> |
|---|---|

Starter key positions

The starter key can be removed in the locking position. Parking lamps, hazard warning flashers and interior lighting can be switched on.

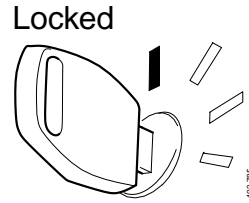

A limited amount of electrical equipment is connected in the radio position.

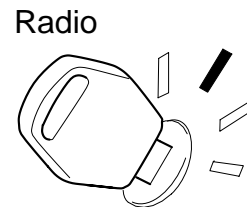

The entire electrical system is connected in the drive position. The warning lamps for battery level, oil pressure, brake pressure, etc., light up.

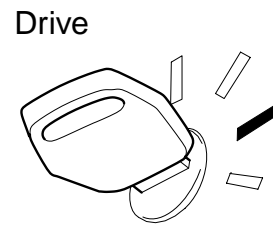

The starter motor is connected in the start position. When the key is released, it returns by spring-action to the drive position.

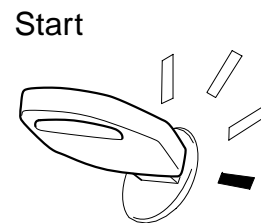

Colour designations on the cables

Designation	Colour
bk	black
bn	brown
rd	red
ye	yellow
gn	green
bu	blue
gy	grey
wh	white

Potentiometer

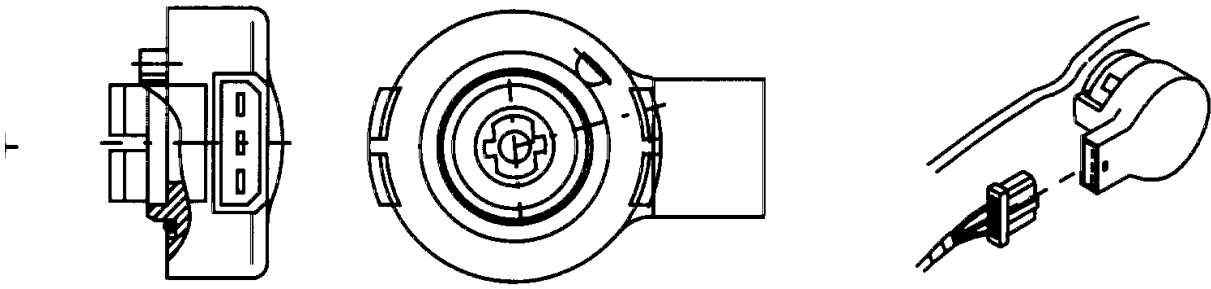

108426

Contact for the potentiometer

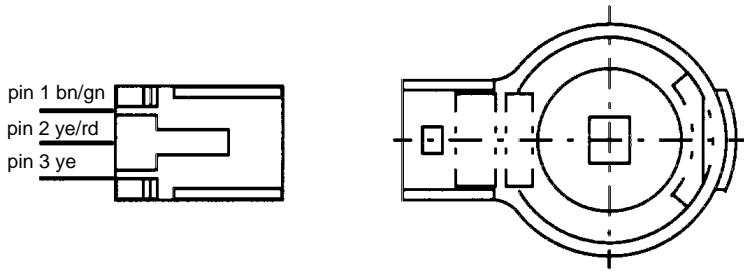

108427

Pin 1: Earth

Pin 2: Signal to and from the potentiometer

Pin 3: Supply voltage

Supply voltage when the key is in the drive position

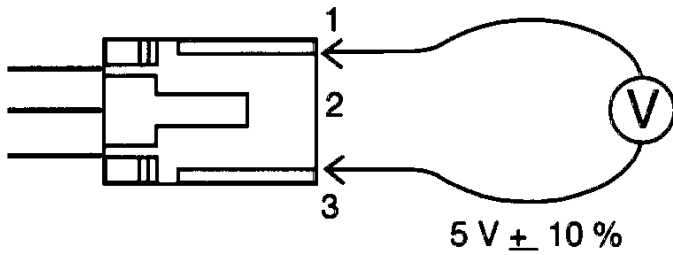

108428

Resistance when the seat squab is at an arbitrary height.

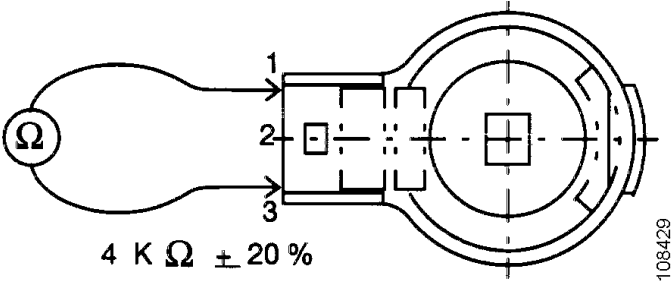

Resistance when the seat squab is in the lowest or highest position.

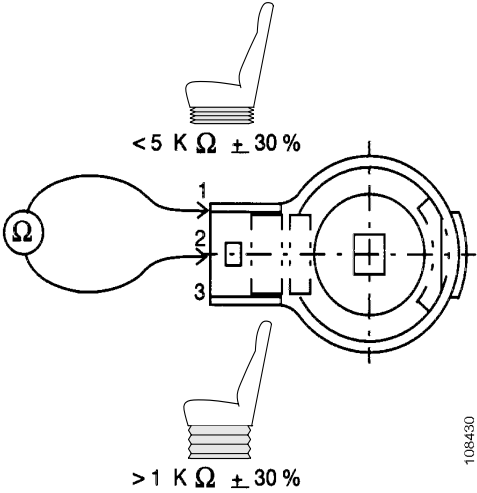

Solenoid valve

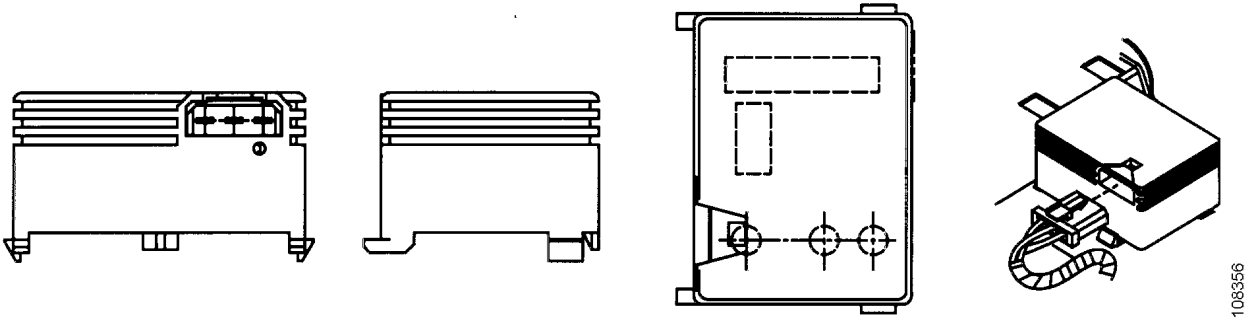

Contact for the solenoid valve

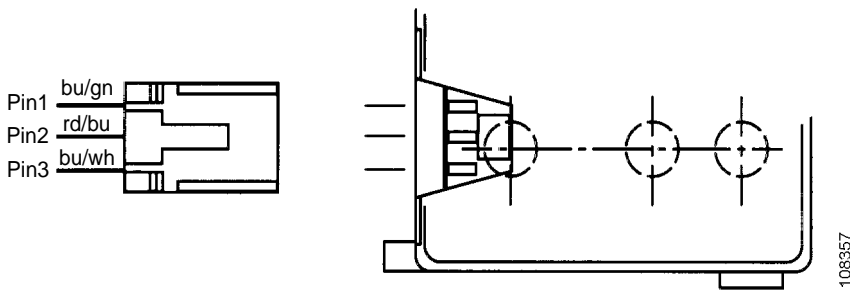

Pin 1: Signal for input

Pin 2: Signal for a constant supply of 24 V

Pin 3: Signal for output

Air connection

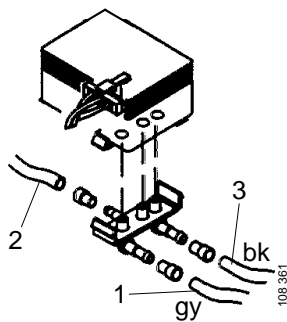

1 Output

2 Air spring

3 Input, 7-10 bar

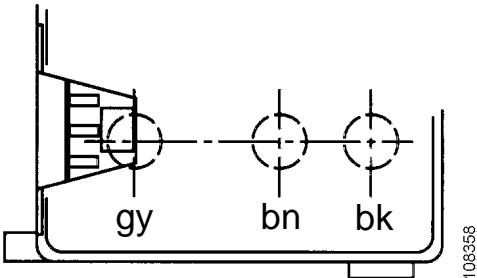

Internal resistance in the output when lowering the seat

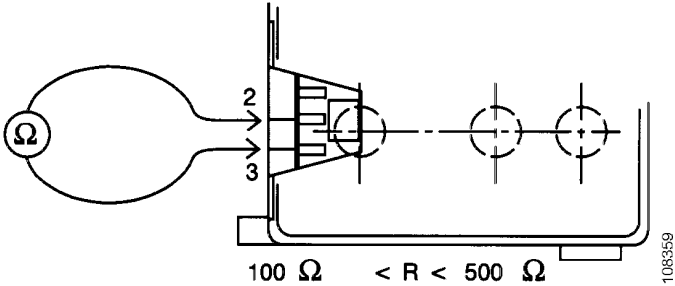

$100 \Omega < R < 500 \Omega$

Internal resistance in the output when raising the seat

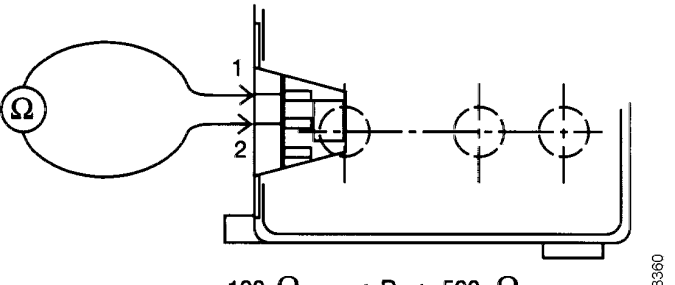

$100 \Omega < R < 500 \Omega$

Control unit

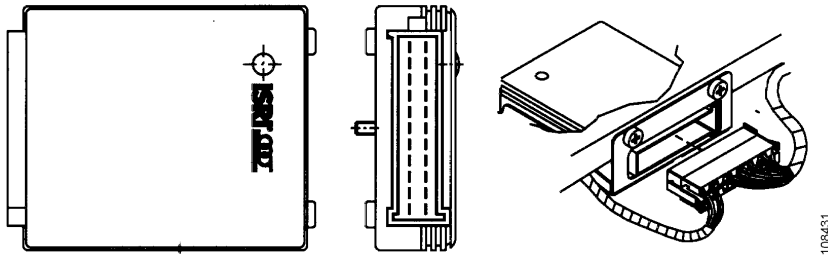

Contact for the control unit

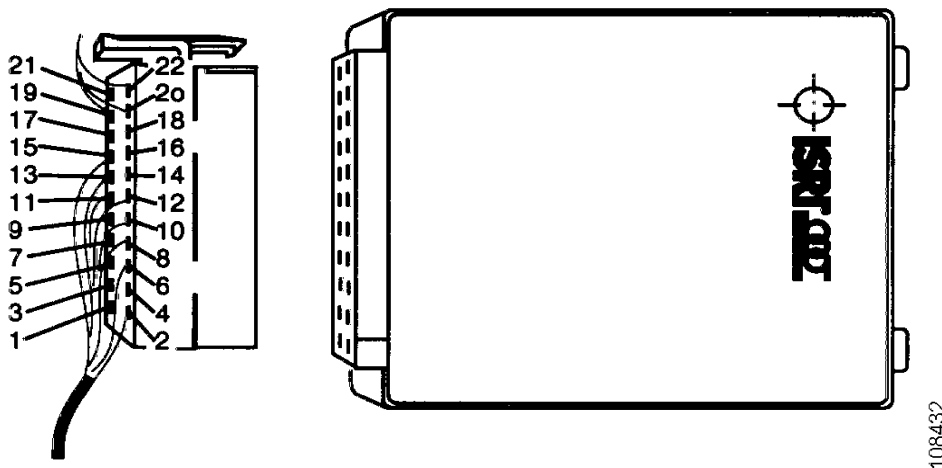

- | | |
|---|--|
| 1 Red, supply voltage | 12 Brown/yellow, button for rapid lowering |
| 2 Black, starter lock | 13 - |
| 3 2 x brown/green, earth | 14 White/yellow, Circuit cable for Diagnos |
| 4 2 x brown/green, earth | 15 - |
| 5 Brown/green, earth | 16 - |
| 6 Yellow, 5 V supply to the potentiometer | 17 Blue/white, output |
| 7 Brown/yellow, signal to and from the seat squab sensor | 18 - |
| 8 Yellow/red, signal to and from the potentiometer | 19 - |
| 9 Brown/grey, height adjustment button, lowering the seat | 20 Blue/green, input |
| 10 Brown/blue, height adjustment button, raising the seat | 21 - |
| 11 - | 22 Red/blue, 24 V supply to the solenoid valve |

When checking the supply of constant voltage, the multimeter should always show 24 volts.

Constant supply voltage

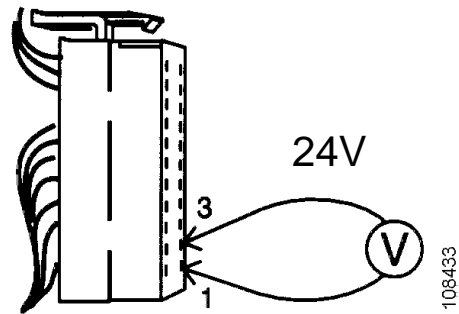

When the key is in the locking position, the multimeter should read 0 volts; when the key is in the drive position, it should show 24 volts.

Supply voltage when the key is in the locking or drive position

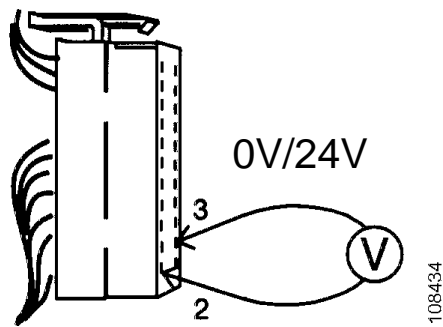

Switch for the heater pads

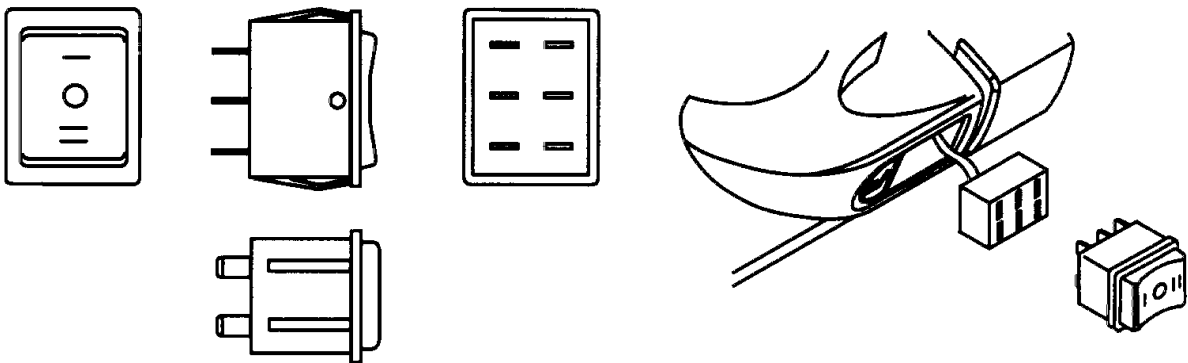

Switch

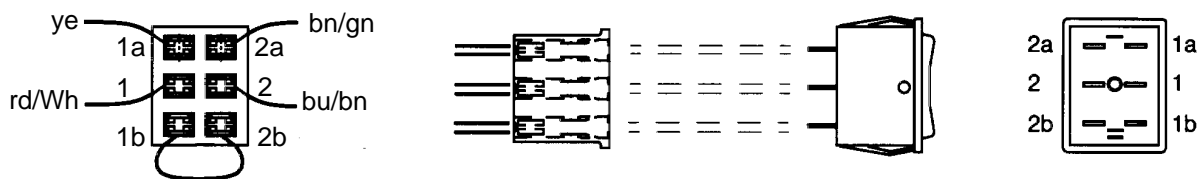

1a Signal from the contact to the heater pads in the seat squab and backrest

1 Supply voltage to the contact

1b

2a Earth

2 Signal from the contact to the backrest heater pad

2b

When the engine is switched off, the multimeter should read 0 volts; when the engine is on, it should read 24 volts.

Supply voltage

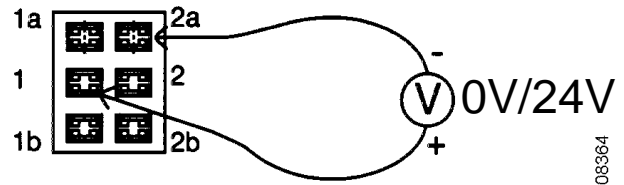

Internal resistance in the backrest heater pad

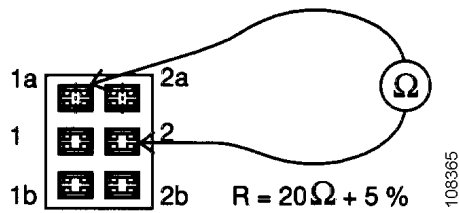

Internal resistance in the heater pad in the seat squab

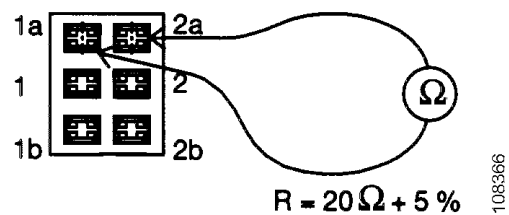

Test with resistance between those pins in the illustration. Set the switch in position one or two.

Switch

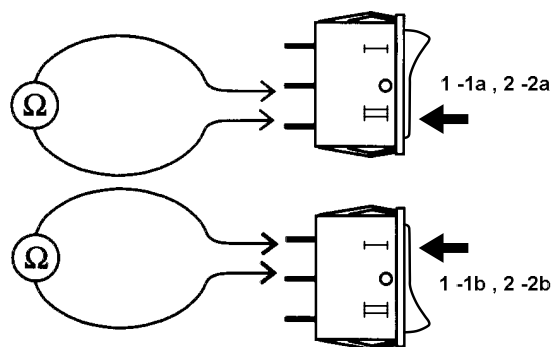

Heater pad

Contacts for the heater pads

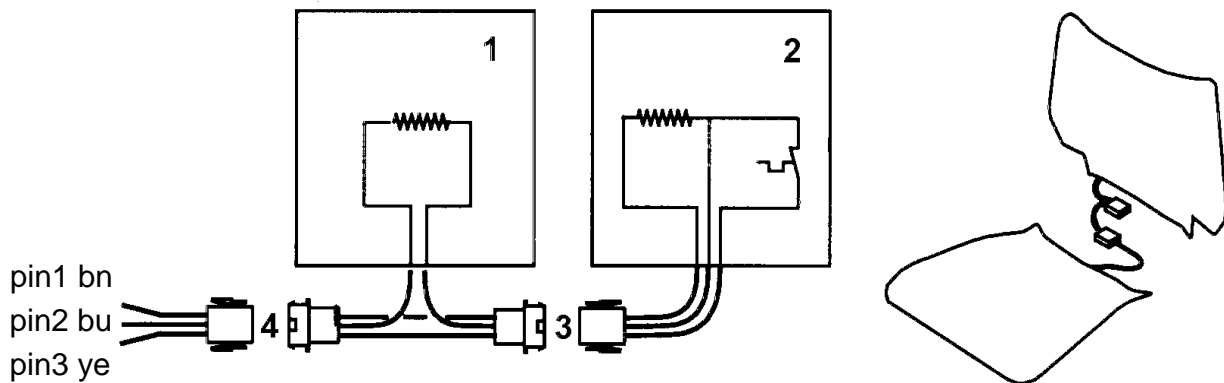

106435

Pin 1: Earth

Pin 2: Signal from the contact to the heater pad in the backrest

Pin 3: Signal from the contact to the heater pads in the seat squab and backrest

1 Heater pad in the backrest

2 Heater pad in the seat squab

3 Contact for the heater pad in the seat squab and backrest

4 Contact for the heater pad in the seat squab and backrest

The switch for the heater pad is connected in series when it is in position one; when it is in position two, it is connected in parallel.

Parallel connection

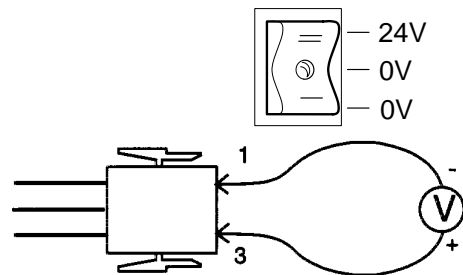

106436

Series connection

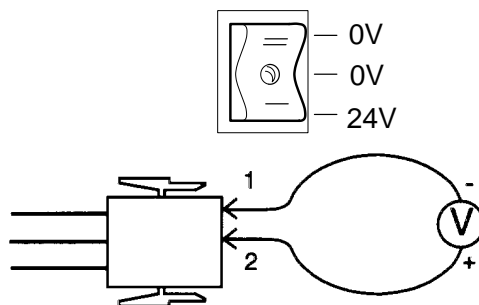

106437

Internal resistance in the backrest heater pad

$R = 20\Omega \pm 5\%$

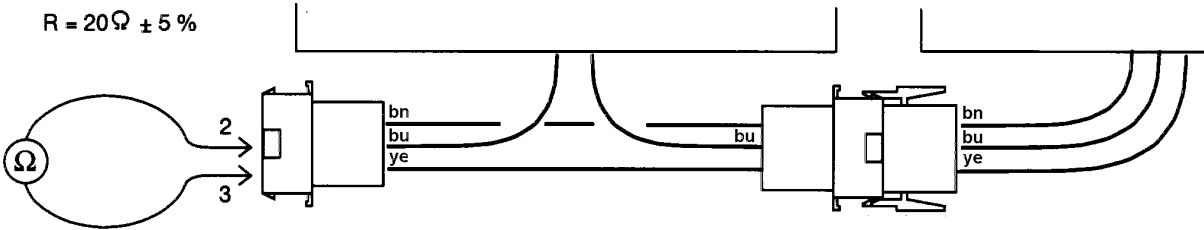

108438

- 1 Heater pad in the backrest
- 2 Heater pad in the seat squab

Internal resistance in the heater pad in the seat squab

$R = 20\Omega \pm 5\%$

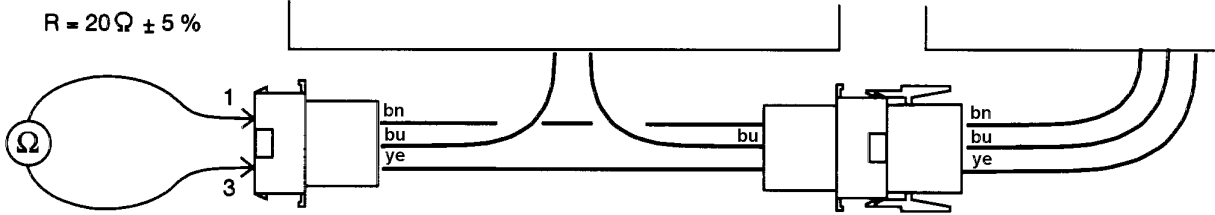

108439

- Heater pad in the backrest
- 3 Heater pad in the seat squab

Contact for the electrical connection of the seat

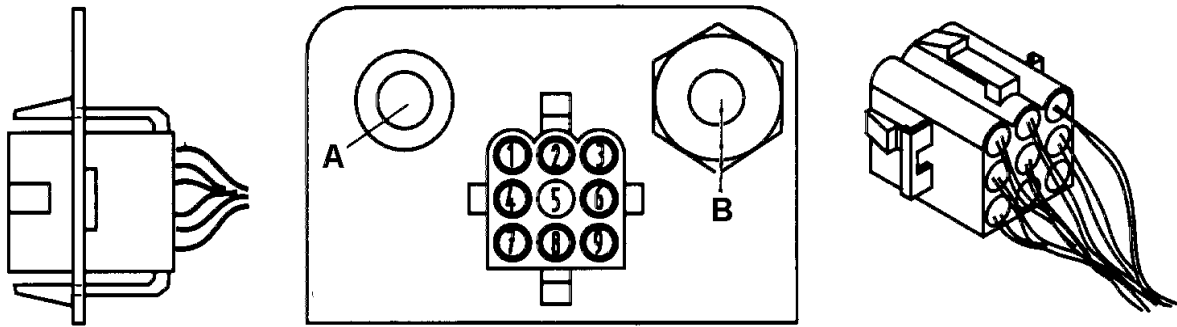

108381

A Output (grey)

B Input (black)

1 30 Battery, 24 volts (red)

2 15 Ignition (black)

3 61 Engine running, heater pad in the seat squab (red/white)

4 ISO-K Seat diagnostics system (white/yellow)

5 Empty

6 31 Earth (brown)

7 Warning lamp and safety belt (brown/blue)

8 Belt tightener (orange)

9 Belt tightener (black)

Note: Avoid short circuits between pins. The contact can be damaged.

The voltage should be $17V < U < 31V$.

Constant supply voltage

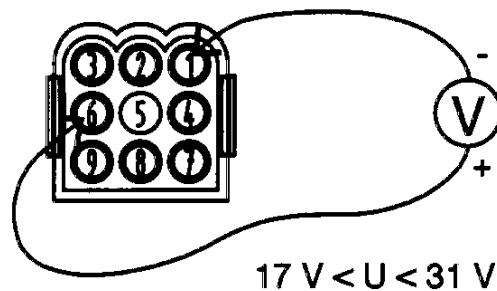

108383

Contact for the cab wiring

Note: Avoid short circuits between pins. The contact can be damaged.

When the key is in the locking position, the multimeter should read 0 volts; when it is in the drive position, the multimeter should show 24 volts.

Supply voltage to the starter key

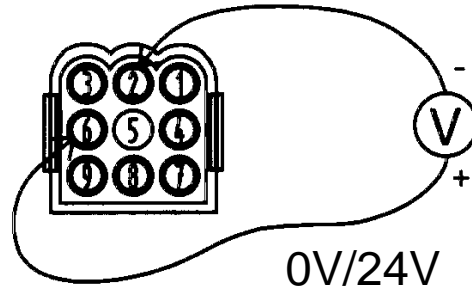

108384

Contact for the cab wiring

Note: Avoid short circuits between pins. The contact can be damaged.

When the engine is switched off, the multimeter should read 0 volts; when the engine is running, it should read 24 volts.

Supply voltage to the heater pad

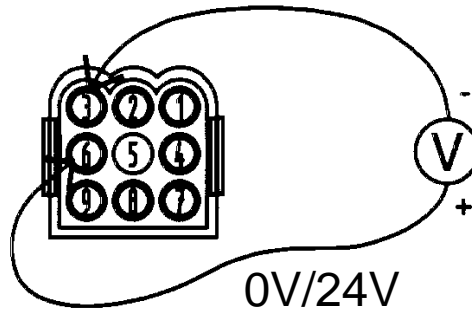

108385

Contact for the cab wiring

When the belt is locked, the multimeter should not register anything; when the belt is not locked, there should be resistance between the pins.

Signal to and from the buckle

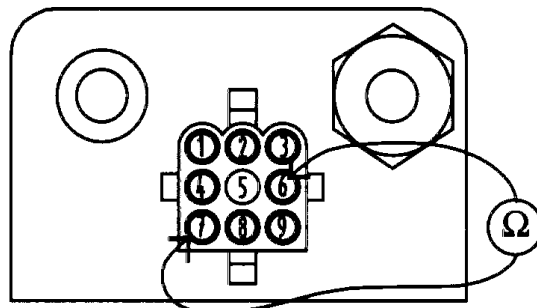

108386

Belt switch

Contact for the switch

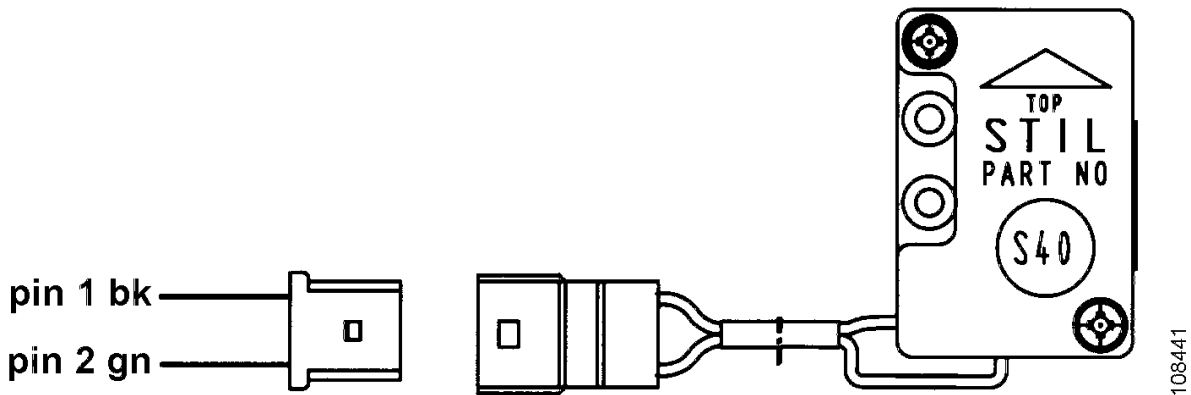

Pin 1: Starter lock

Pin 2: Signal to and from the switch

The seat should not be in the vehicle.

When the switch is in the upright position, there should be resistance between the pins.

Checking the switch in the upright position

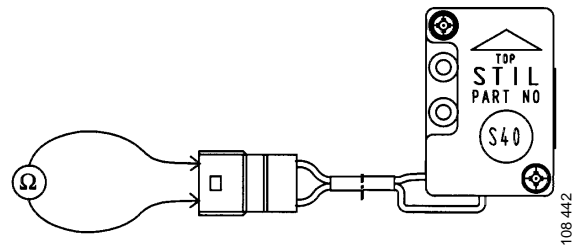

The seat should not be in the vehicle.

When the switch is at an angle greater than 30 degrees, the multimeter should not register anything.

Checking the switch when it is at an angle

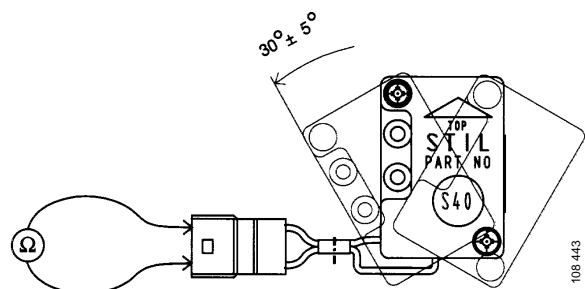

Button for adjusting height

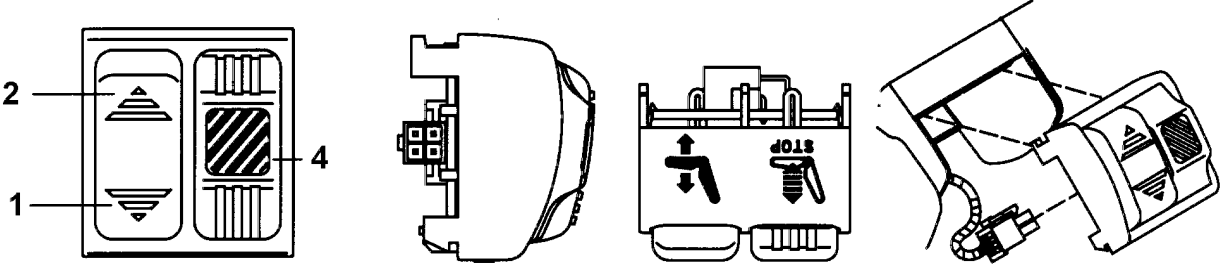

108387

- 1 Button for adjusting height, lowering*
- 2 Button for adjusting height, raising*
- 4 Button for rapid lowering*

Contact for the buttons on the left-hand side of the seat

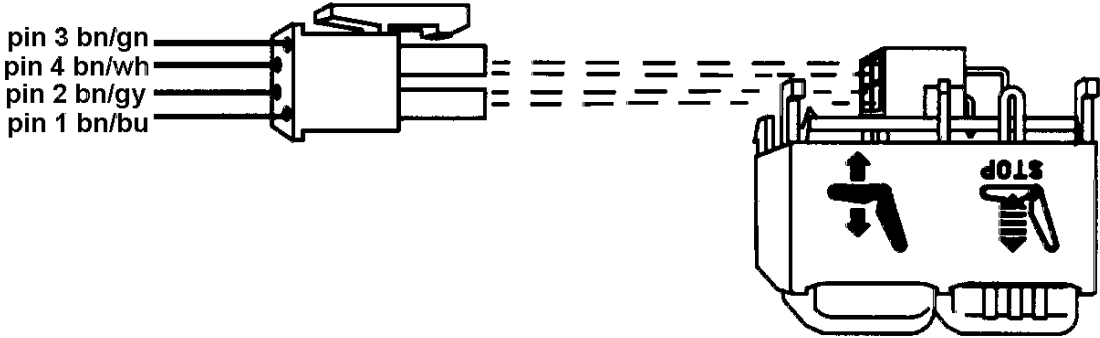

108388

- Pin 3: Earth*
- Pin 4: Button for rapid lowering*
- Pin 2: Button for adjusting height, raising*
- Pin 1: Button for adjusting height, lowering*

Contact for the buttons on the right-hand side of the seat

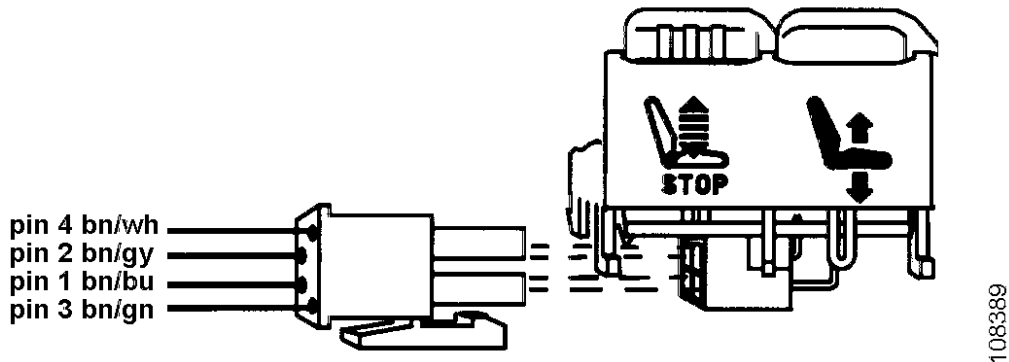

Pin 4: Button for rapid lowering

Pin 2: Button for adjusting height, raising

Pin 1: Button for adjusting height, lowering

Pin 3: Earth

Buttons during lowering, right-hand side of the seat

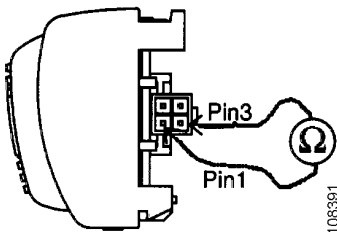

Buttons during lowering, left-hand side of the seat

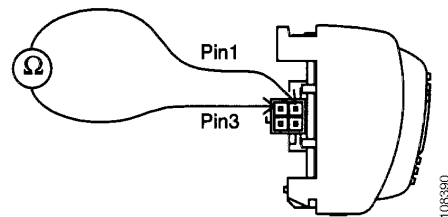

When the button for adjusting height is not in the depressed position, the multimeter should not register anything. When the lower part of the button (for lowering the seat) is in the depressed position, there should be resistance between the pins.

Buttons during raising, right-hand side of the seat

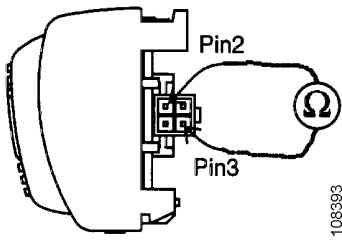

Buttons during raising, left-hand side of the seat

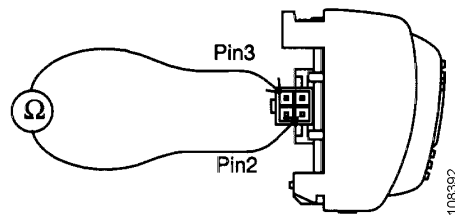

When the button for adjusting height is not in the depressed position, the multimeter should not register anything. When the upper part of the button (for raising the seat) is in the depressed position, there should be resistance between the pins.

Buttons during rapid lowering, right-hand side of the seat

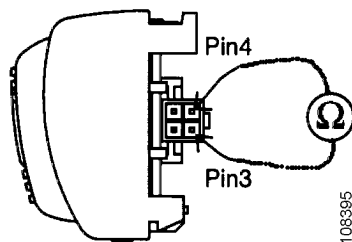

Buttons during rapid lowering, left-hand side of the seat

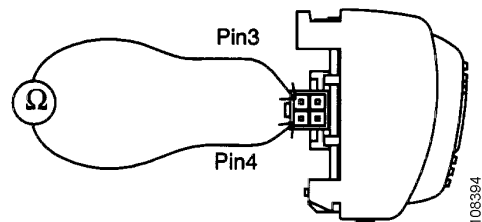

When the button for the rapid-lowering function is not in the depressed position, the multimeter should not register anything. When the button is in the depressed position, there should be resistance between the pins.

Buckle

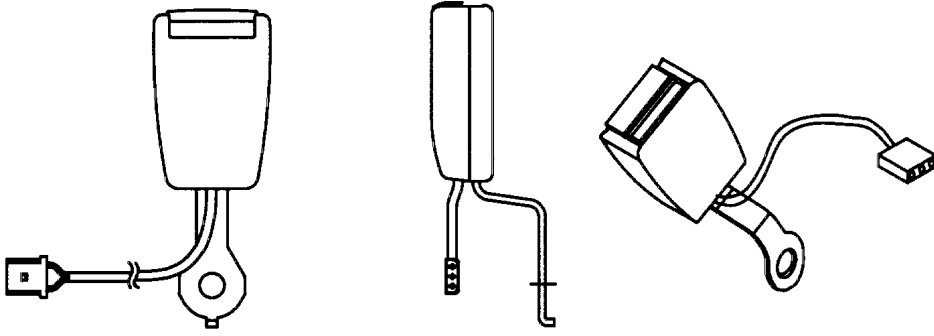

108444

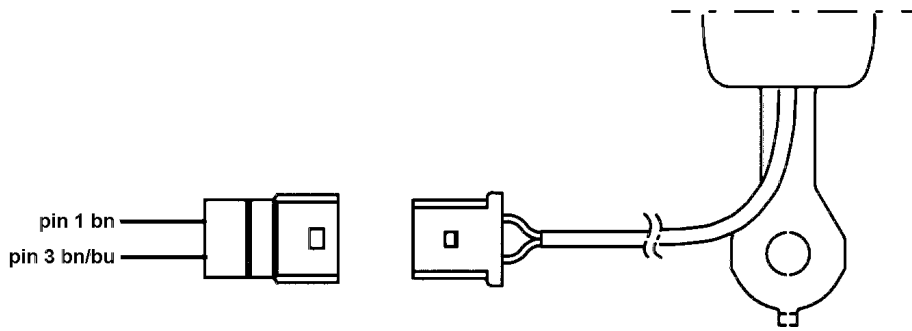

108445

Pin 1: Earth

Pin 3: Signal to and from the buckle

When the belt is locked, the multimeter should not register anything; when the belt is not locked, there should be resistance between the pins.

Contact for the buckle

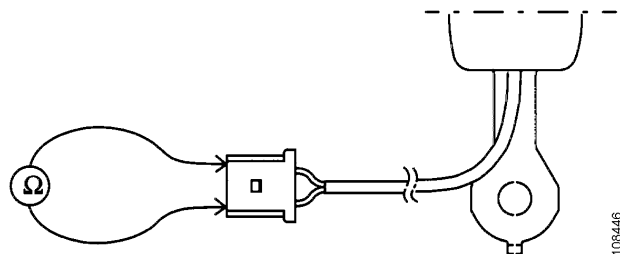

108446

Inertia reel

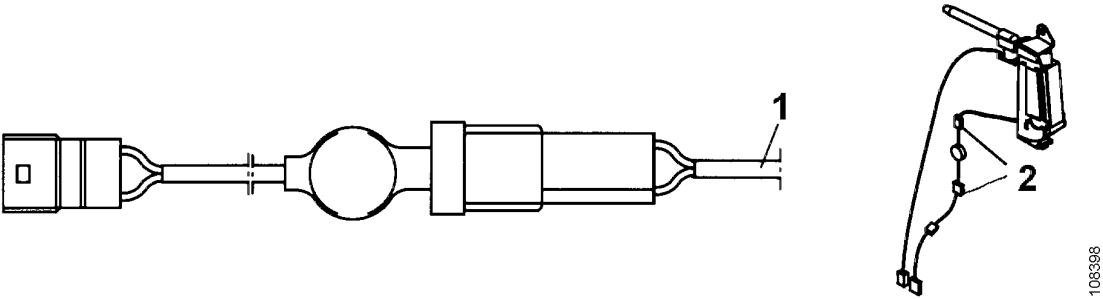

- 1 To the inertia reel
- 2 Contacts for the varistor

Contact for the inertia reel

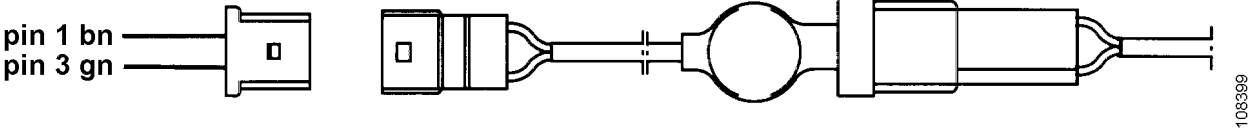

- Pin 1: Earth
- Pin 3: Signal to and from the belt switch

Internal resistance in the contact for the inertia reel

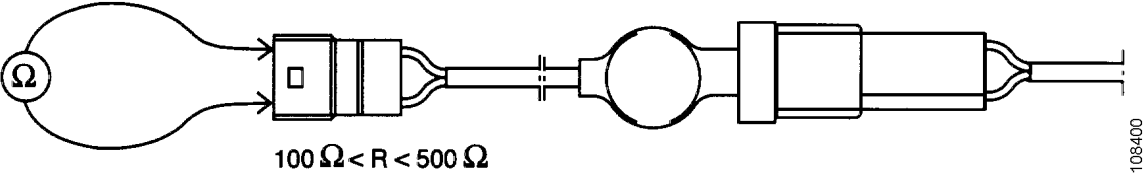

Sensor in the seat squab

Seats with the following part numbers are equipped with a sensor: 1 395 501-1 395 508 and 1 345 787-1 345 790.

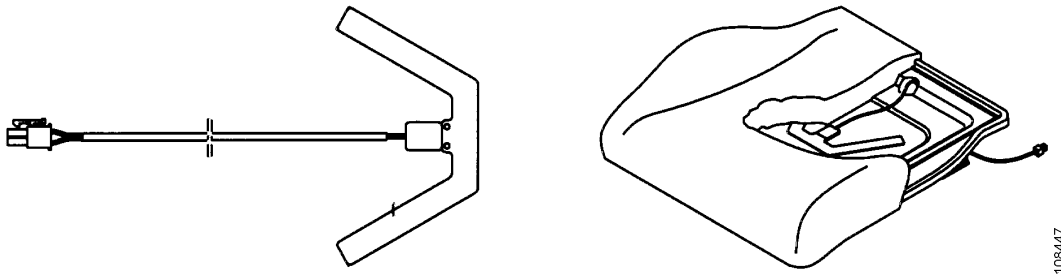

Contact for the sensor

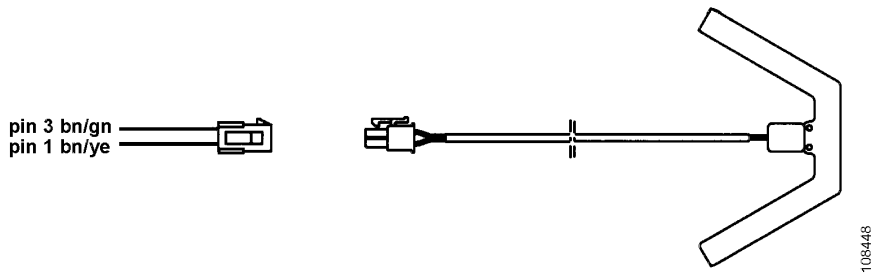

Internal resistance in the contact

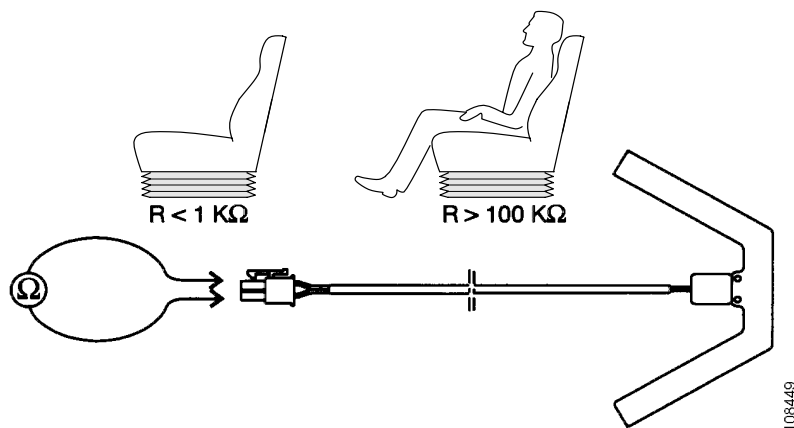

Work description

This section contains:

- exploded views;
- spot repairs;
- instructions on how to remove the seat and its component parts.

Seat

exploded views;

Luxury A

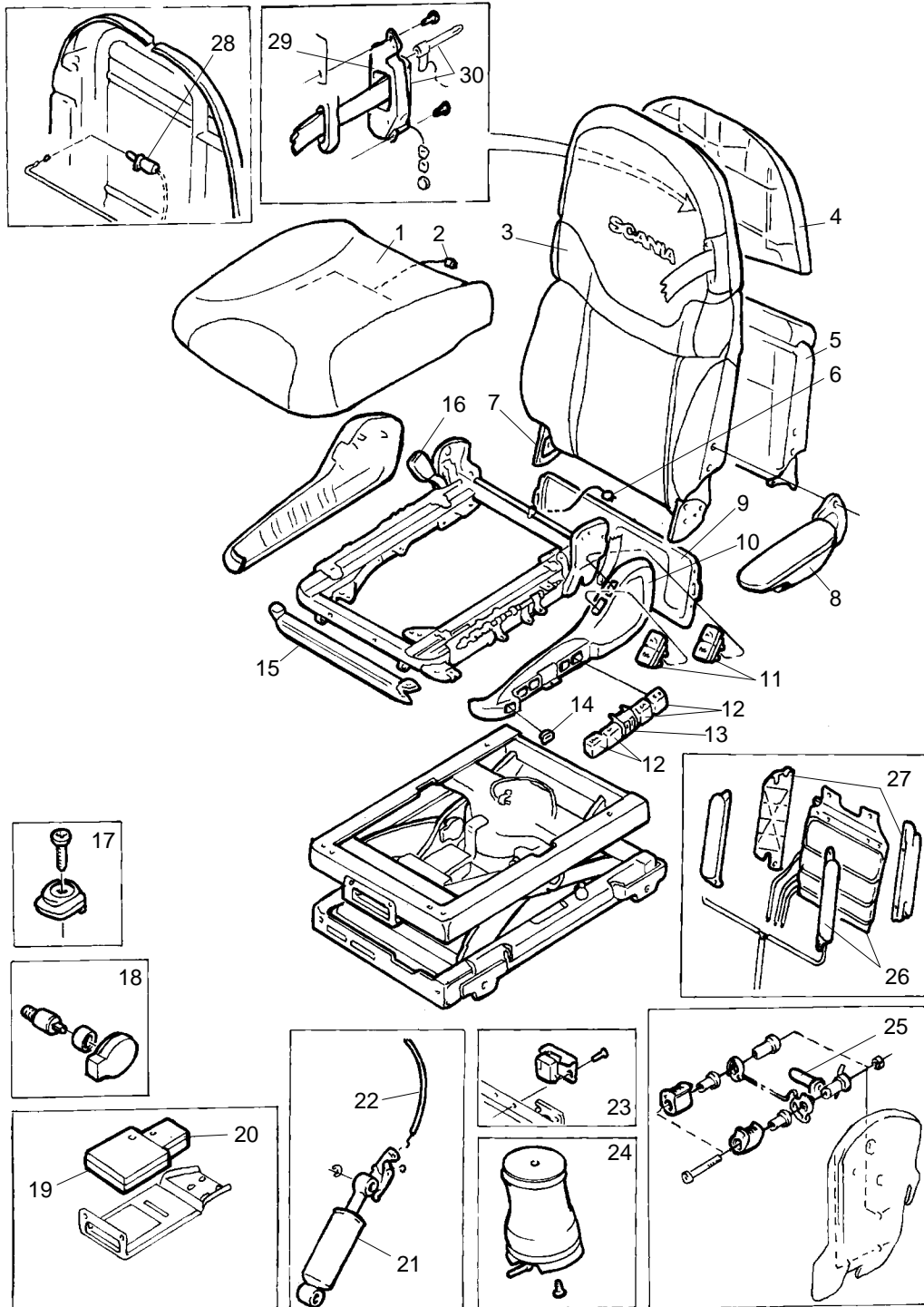

107 553

- 1 *Seat squab*
- 2 *Heater pad in the seat squab*
- 3 *Backrest*
- 4 *Upper backrest casing*
- 5 *Lower backrest casing*
- 6 *Heater pad in the backrest cushion*
- 7 *Gear segment*
- 8 *Armrest*
- 9 *Lower rear casing*
- 10 *Side casing*
- 11 *Control valves for the side supports and lumbar support*
- 12 *Buttons*
- 13 *Button for adjusting height*
- 14 *Switch for the heater pad*
- 15 *Front casing*
- 16 *Buckle*
- 17 *Slider*
- 18 *Potentiometer*
- 19 *Control unit*
- 20 *Solenoid valve*
- 21 *Shock absorber*
- 22 *Cable for the shock absorber*
- 23 *Switch*
- 24 *Air spring*
- 25 *Lower air valve*
- 26 *Air cushions for the side supports and lumbar support*
- 27 *Support*
- 28 *Upper air valve*
- 29 *Inertia reel*
- 30 *Inertia reel and belt tightener*

Medium A

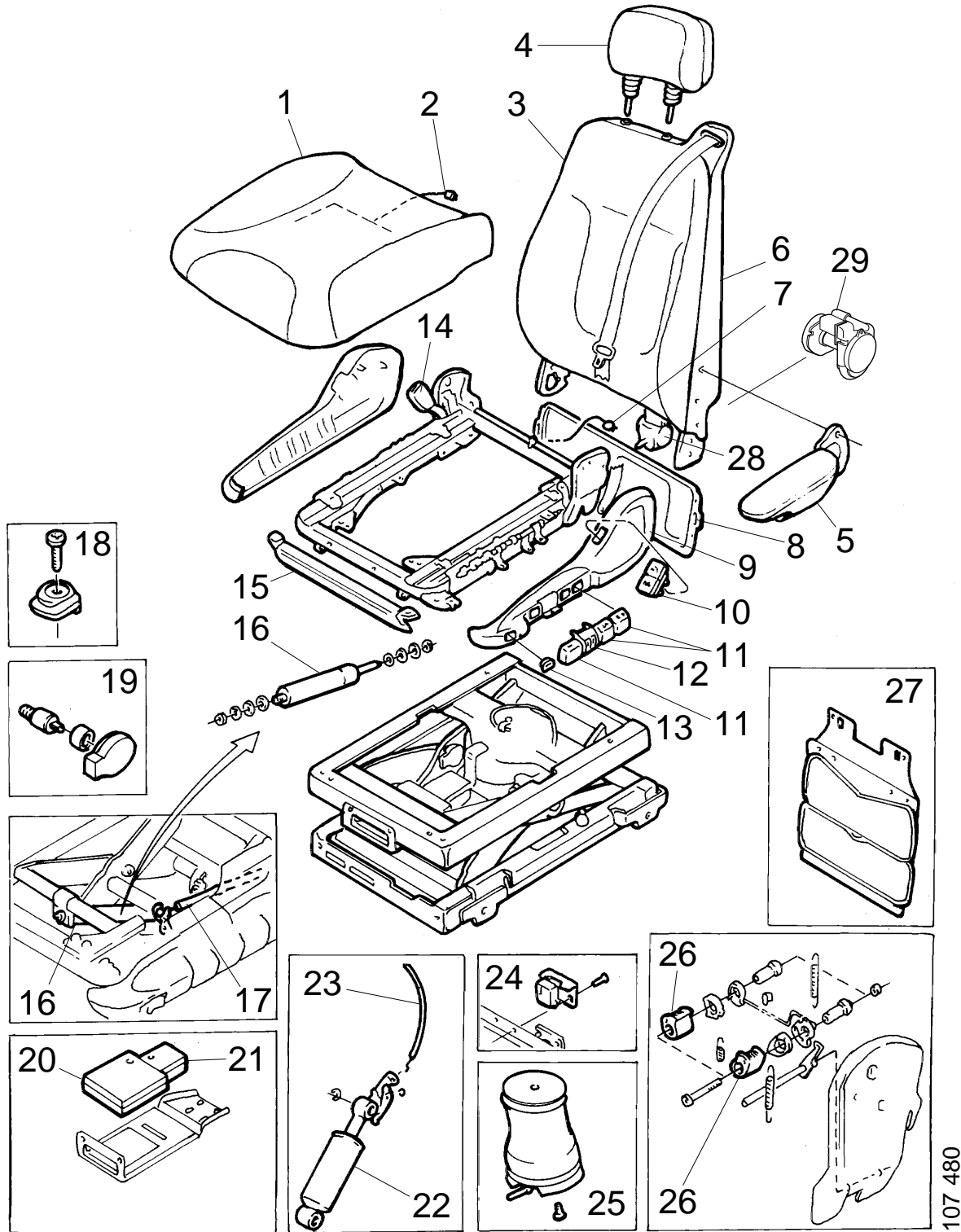

107 480

- 1 *Seat squab*
- 2 *Heater pad in the seat squab*
- 3 *Backrest*
- 4 *Head restraint*
- 5 *Armrest*
- 6 *Backrest casing*
- 7 *Heater pad in the backrest cushion*
- 8 *Lower rear casing*
- 9 *Side casing*
- 10 *Control valve for the side supports and lumbar support*
- 11 *Buttons*
- 12 *Button for adjusting height*
- 13 *Switch for the heater pad*
- 14 *Buckle*
- 15 *Front casing*
- 16 *Gas spring*
- 17 *Cable for the gas spring*
- 18 *Slider*
- 19 *Potentiometer*
- 20 *Control unit*
- 21 *Solenoid valve*
- 22 *Shock absorber*
- 23 *Cable for the shock absorber*
- 24 *Switch*
- 25 *Air spring*
- 26 *Ratchet segment*
- 27 *Air cushion for the lumbar support*
- 28 *Inertia reel*
- 29 *Inertia reel and belt tightener*

spot repairs;

If the shock absorber becomes rigid

If the seat is subjected to much excitation during driving, it can suddenly become rigid.

- 1 Set the shock absorber at "soft".

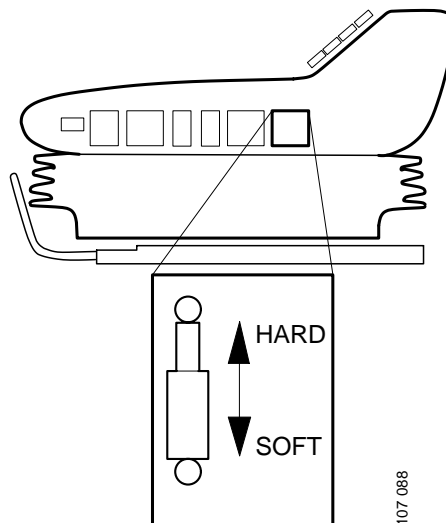

- 2 Rock the seat up and down a couple of times with your hands.
- 3 Press the seat down hard using the full weight of your body.

If the seat becomes rigid and refuses to move, there is a fault with the shock absorber, see *Shock absorber*.

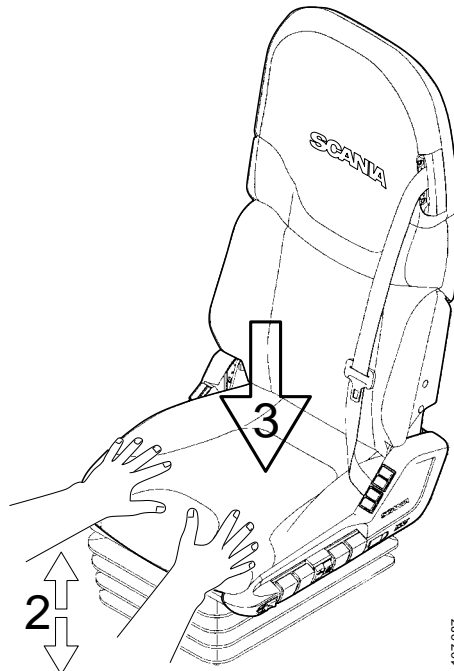

If the height adjustment malfunctions

Check the following

- 1 Look to see if there are any fault codes.
 - 2 Listen for air leaking from the seat.
 - 3 Make sure that the seat pin assembly 1 is not jamming.
 - 4 Disconnect the control unit contact and reconnect it again. The contact pins might be oxidised.
 - 5 Make sure that the potentiometer 2 is correctly positioned and secured.
 - 6 Check that the shock absorber is intact and functioning properly.
 - 7 Check that the solenoid valve 3 is not blocked with particles of dirt. If it is, fit a new solenoid valve and a new filter. See *Fitting the solenoid valve and filter* and *Solenoid valve* in the "Work description".
- Seats as and from serial number 61 970 131 433 have a filter between the boot and solenoid valve.
- 8 Change the control unit 4.

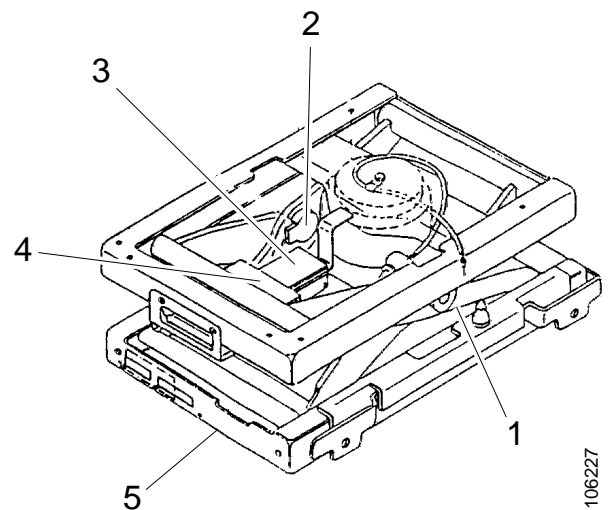

- 1 *Pin assembly*
- 2 *Potentiometer*
- 3 *Solenoid valve*
- 4 *Control unit*
- 5 *Serial number*

106227

Fitting the solenoid valve and filter

- 1 The solenoid valve and filter are supplied together as a spare part kit.

To change the solenoid valve, cut the hose between the solenoid valve and the air spring (see the illustration).

- 2 Fit the air filter on to the air hose between the air spring and the solenoid valve (see the illustration).
- 3 Clamp the hoses.

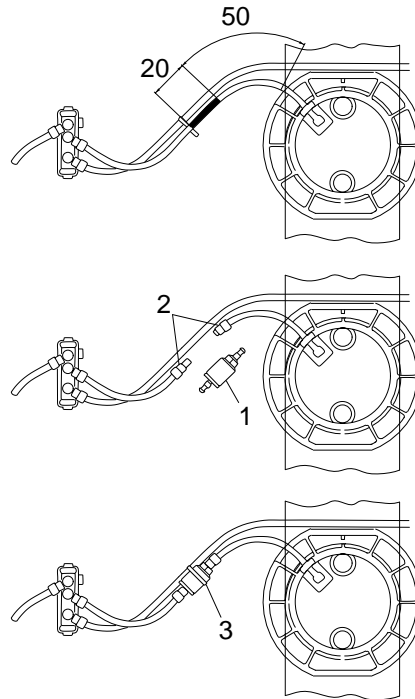

- 1 *Air filter*
- 2 *Clamps*
- 3 *Hose clamp*

If the seat rattles

If the seat rattles, it can be due to one of the following parts being loose. If so, tighten the screws.

- 1 There might a gap in the shock absorber bracket. Tighten the screw to 20 +/- 2 Nm.

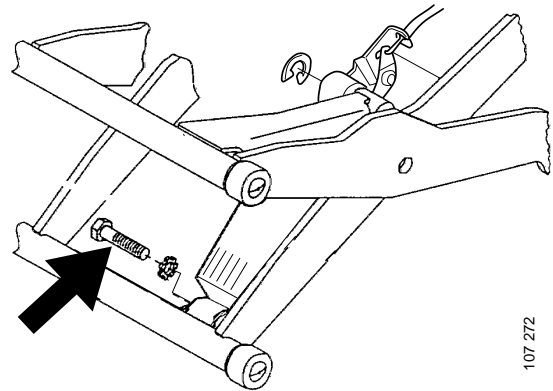

107 272

- 2 There might be a gap in the pin assembly. Tighten the screws to 20 +/- 2 Nm.

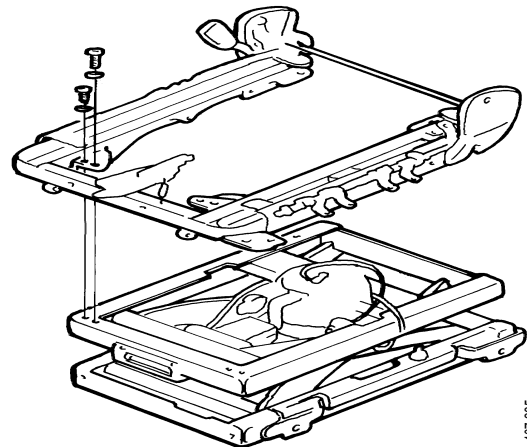

107 265

Repair kit for the air hoses

A repair kit for air hoses is available. It contains two sizes of hose, joining unions and connections for repairing a leak in the system.

IMPORTANT! Do not subject the hoses to excessive bending. A sharp bend can cause blocking.

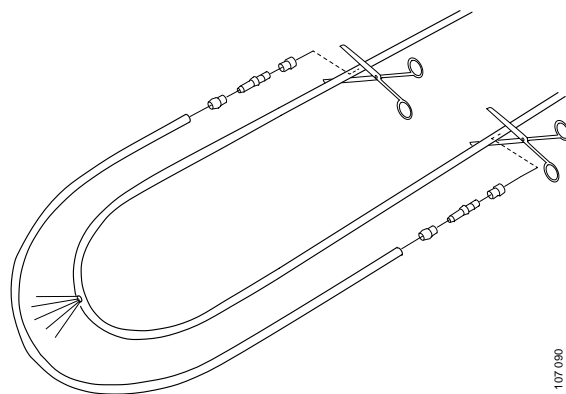

107 080

Warning when working on the seat

Block for some types of repair



WARNING!

Always secure the seat with a block to prevent your limbs from being trapped.

As a precaution against limbs becoming trapped when working on the seat, it is necessary to make a block.

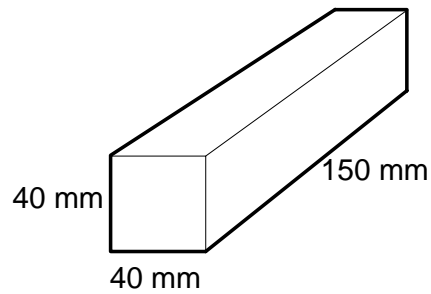

The block is used to secure the seat in the raised position.



Changing the seat

Removal



WARNING!

If the seat has a belt tightener, disconnect all the power sources in the vehicle.

- 1 Lower the seat fully to empty the air spring of air.
- 2 Disconnect the contact at the rear of the seat.
- 3 Disconnect the rapid-action coupling on the left-hand air hose by pressing the black plastic ring. Pull the air hose off.

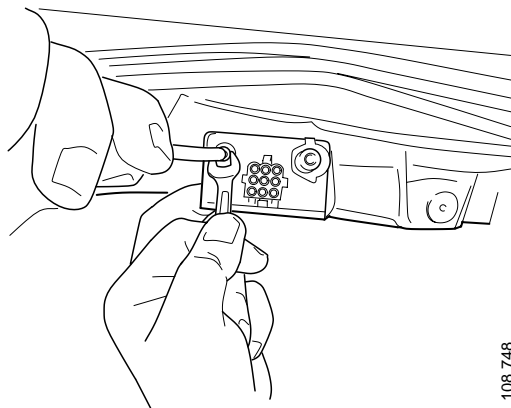

108 748

Left-hand air hose

- 4 Cut the **right-hand** air hose as close to the seat as possible.

- 5 Remove the two screws securing the seat in place.

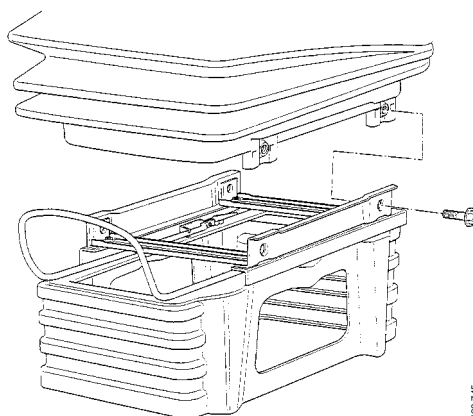

108 745

- 6 Loosen the seat on one side and remove the guide pins from the holes.
- 7 Before the seat can be refitted, the hose in the supply connection must first be removed.

Dismantle the supply connection.

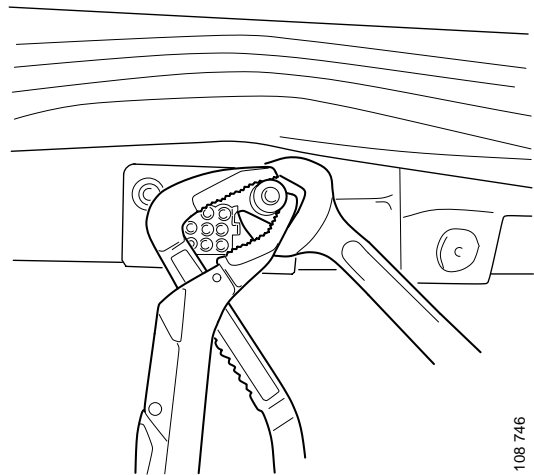

108 746

- 8 Remove the hose.
- 9 Make sure that the two O-rings are still in the supply connection. Screw the supply connection together again.

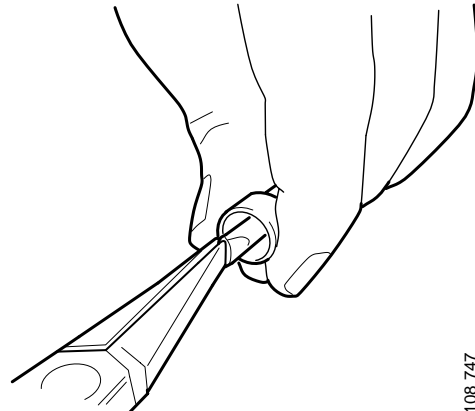

108 747

Seat squab

Seat squab with seat-depth setting

- 1 Push the seat squab to its forwardmost position.
- 2 Undo the Velcro tape at the rear of the seat squab.
- 3 Pull the handle 3 in the direction of the arrow and hold it there firmly.
- 4 Continue to pull the seat squab forward as far as it will go and then lift it up.
- 5 Disconnect the electrical connections 1 and 2 for the heater pads.

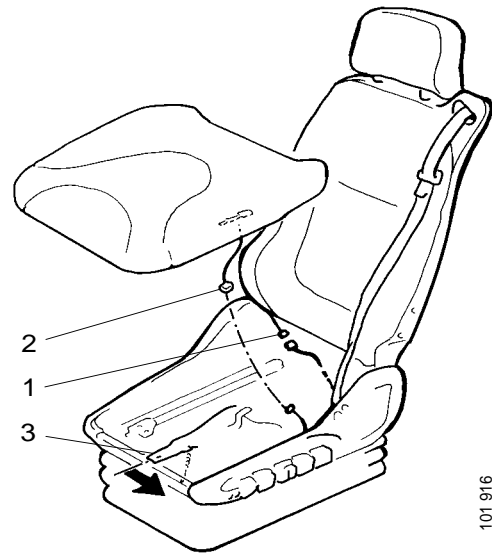

Note: Refit the seat squab carefully to avoid trapping the cables.

Slider

- 1 Remove the seat squab.
- 2 Remove the screw 2 and change the slider 1.

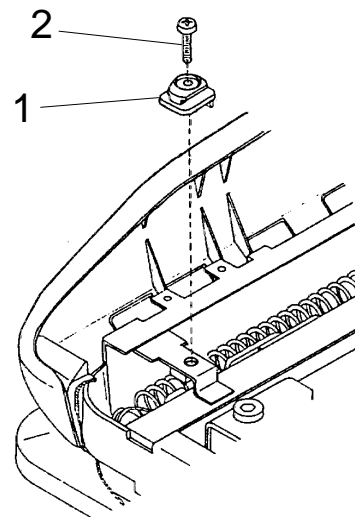

Seat squab without a seat-depth setting in Medium A

- 1 Press the handle 3 in the direction of the arrow and hold it firmly.
- 2 Push the seat squab to its forwardmost position and lift.
- 3 Undo the Velcro tape at the rear of the seat squab.
- 4 Disconnect the electrical connections 1 and 2 for the heater pads.

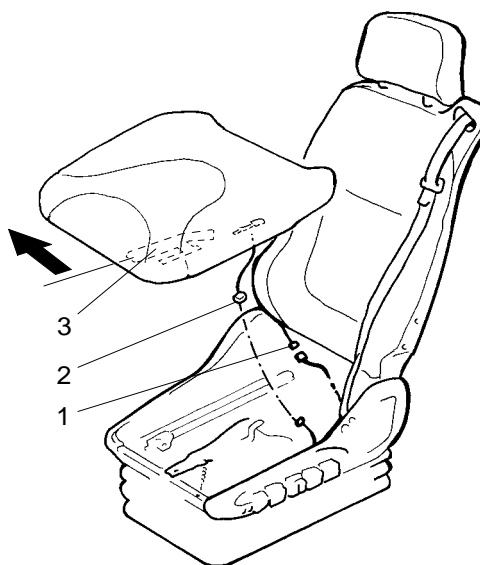

101 599

Note: Refit the seat squab carefully to avoid trapping the cables.

Seat squab upholstery

Tools

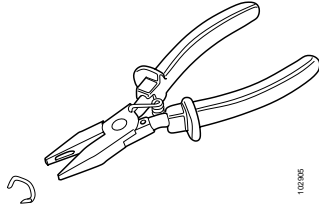
Number	Designation	Illustration	Tool board
588 134	Pliers		None
1 411 488	Staple		None

Removal

- 1 Remove the seat squab.
- 2 Unfold the upholstery from the bottom plate.
- 3 Remove the staples 1.
- 4 Remove the upholstery.

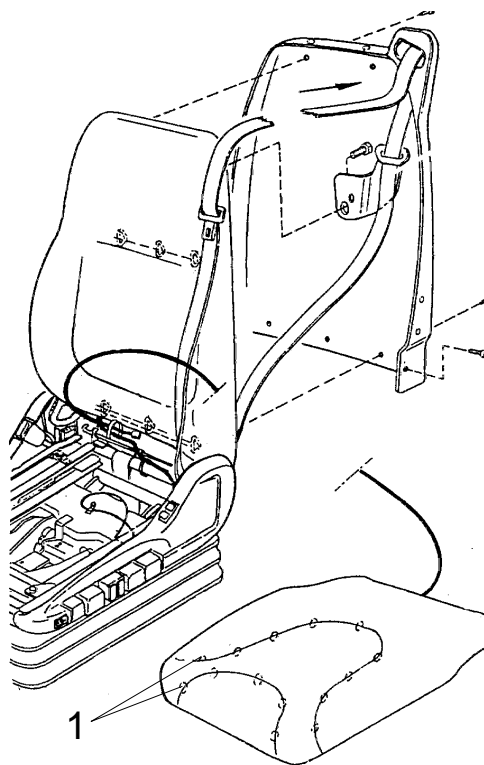

Use staples and pliers to refit the upholstery.

Note: Make sure that the staple points can't penetrate the upholstery.

Heater pad in the seat squab

- 1 Remove the seat squab.
- 2 Remove the upholstery from the seat squab.
- 3 Method 1: Peel the old heater pad carefully away from the squab and stick the new pad into place.

Method 2: Cut the cables and the thermostat
2. Stick the new heater pad on top of the old one.

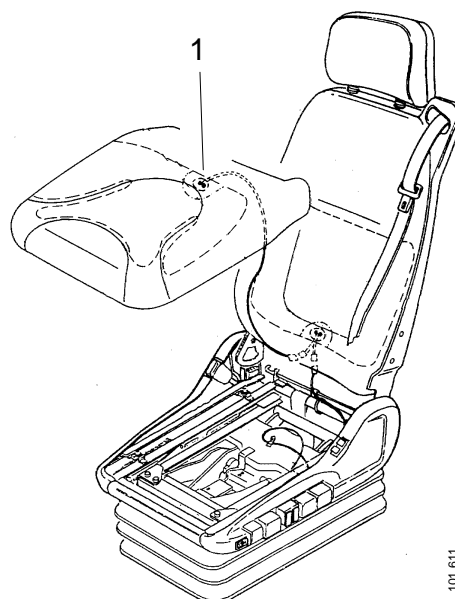

Buttons and controls

Control valve for the side supports and lumbar support

- 1 Push the seat squab forward.
- 2 Press the control valve out of position from the inside.
- 3 Disconnect the hoses.
- 4 Change the control valve.

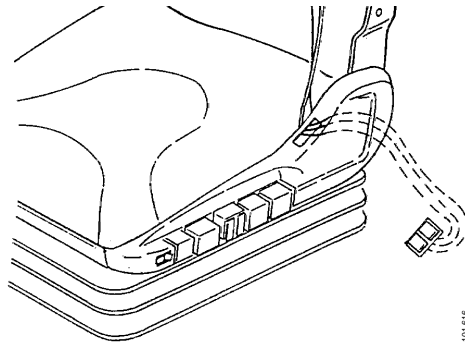

Buttons

- 1 Press the button out of position from below using a drift or similar tool.

Note: Change the control button.

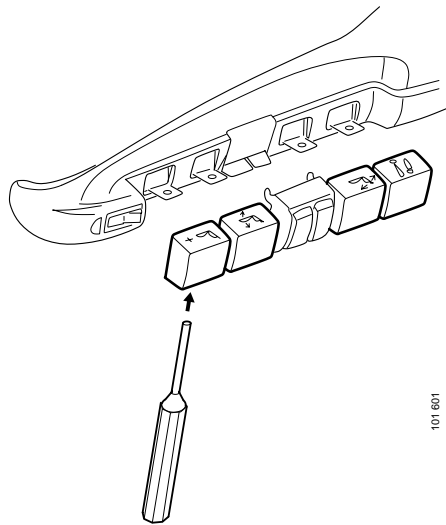

Button for adjusting height

- 1 Grip the lower part of the button 1, push it upwards and outwards.
- 2 Disconnect the cable 2.

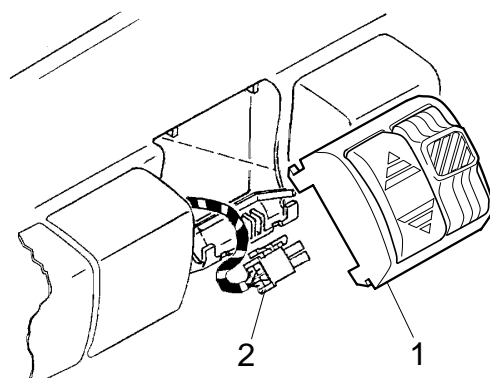

Switch for the heater pad

- 1 Remove the seat squab.
- 2 Push the switch 1 out of position from the inside.

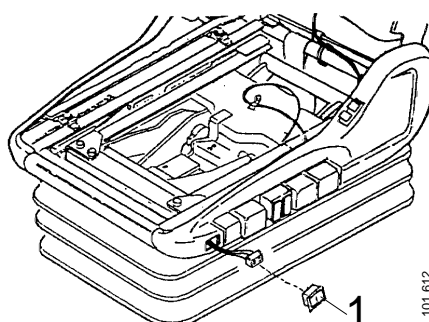

Casing on the lower part of the seat

Side casing with control buttons

- 1 Remove the seat squab.
- 2 Remove the button assembly.
- 3 Remove the screws 1.
- 4 Loosen the rear/lower plastic casing 2.
- 5 Remove the lumbar support valve 3.
- 6 Remove the button 4 for the heater pad.
- 7 Remove the side casing.

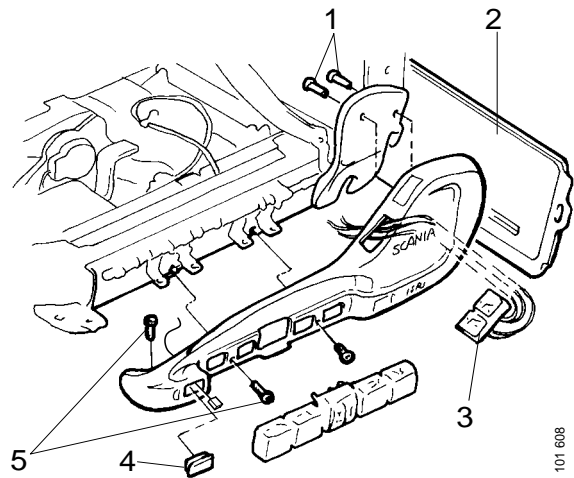

Side casing without control buttons

- 1 Remove the seat squab.
- 2 Remove screws 1 and 2.
- 3 Loosen the rear/lower plastic casing 3.
- 4 Remove the side casing 4.

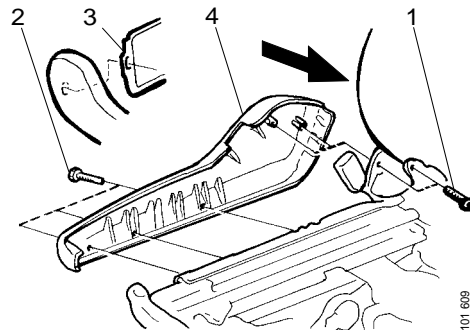

Front casing

- 1 Remove the seat squab.
- 2 Tilt the front section as high as it will go.
- 3 Remove the screws 2.
- 4 Undo the front screws on the side casing without the control buttons.
- 5 Extend the side casing and remove the front casing 1.

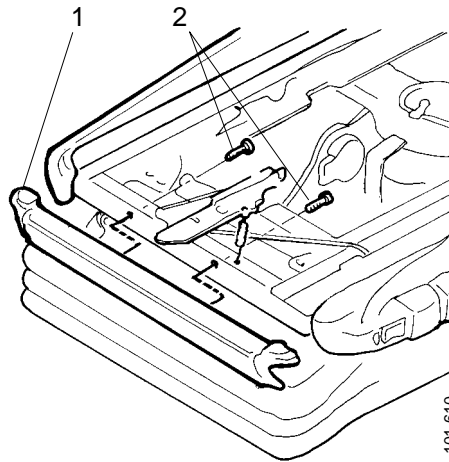

Lower rear casing

- 1 Remove the side casing without the control buttons.
- 2 Remove the red handle 1 on Luxury A.
- 3 Remove the rear/lower casing 2.

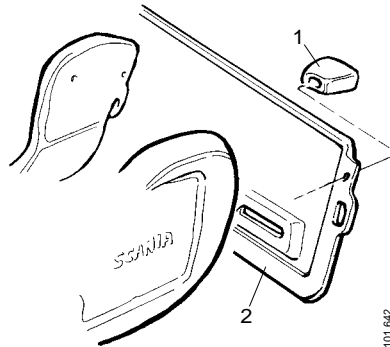

Backrest

Backrest

- 1 Remove the seat.
- 2 Remove the seat squab.
- 3 Remove the strap 1 for the cables and air hoses.
- 4 Disconnect the cables and air hoses.
- 5 Remove the side casing with the control buttons.
- 6 Remove the lower rear casing.
- 7 Remove the retaining screw 2 for the belt.
- 8 Remove the inertia reel 3 in Medium A.
- 9 Remove the retaining screws 4, one on each side of the backrest cushion.
- 10 Tilt the backrest cushion forwards 90 degrees. Prize it loose and lift it off.

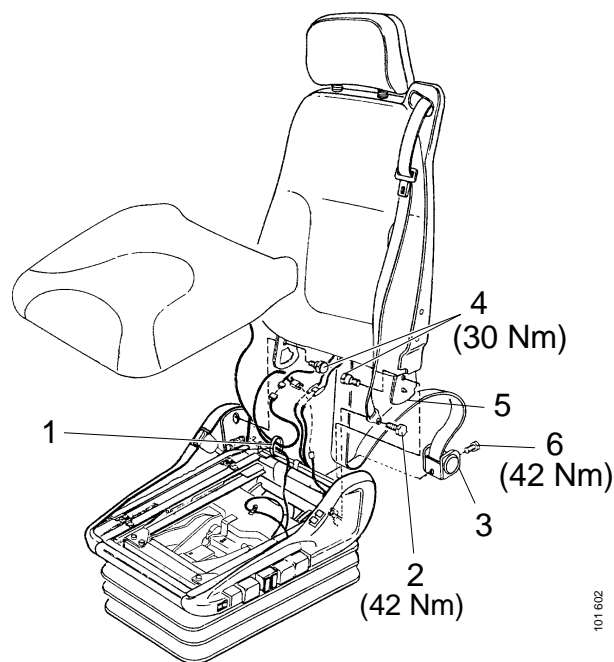

Note: Protect ratchet segment 5 from damage.

When fitting

- 1 Use locking fluid on the screws.
- 2 Tighten screws 4 to 30 Nm, and screws 2 and 6 to 42 Nm.

Head restraint on Medium A

- 1 Pull the head restraint upwards to the uppermost position.
- 2 Press the latch clamps 1 firmly to the side while pulling the head restraint upwards.

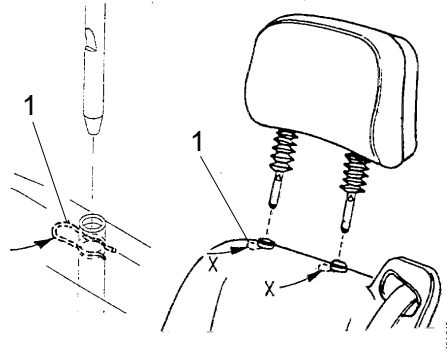

Armrest

- 1 Remove the cover from the backrest casing.
- 2 Detach the armrest by removing the two screws.

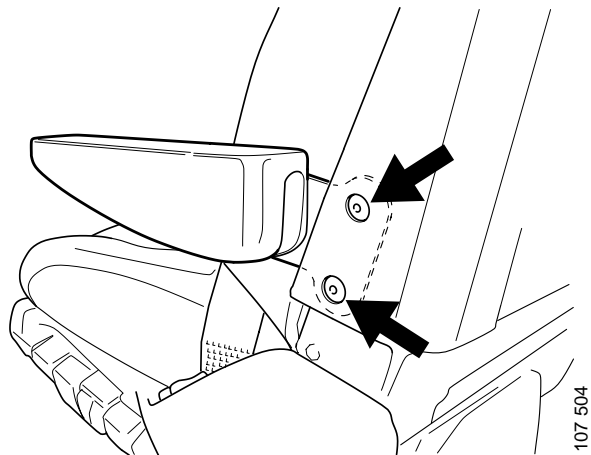

Backrest casing on Luxury A

- 1 Push the upper part of the backrest forward as far as it will go.
- 2 Remove the screws 2 from the handle 1.
- 3 Remove the remaining screws 3 from the casing.

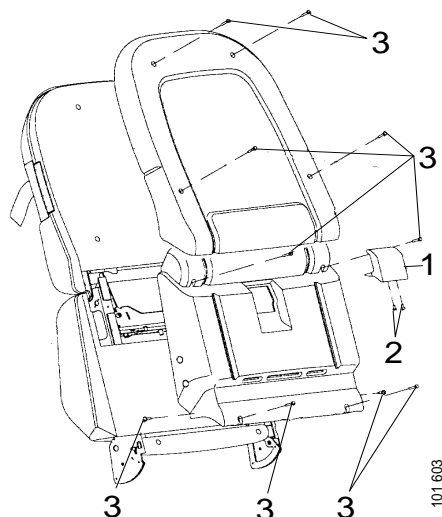

Backrest casing on Medium A

- 1 Remove the seat squab.
- 2 Remove the head restraint.
- 3 Remove the side casing with the control buttons.
- 4 Remove the retaining screws 5 for the belt.
- 5 Remove screws 3 and 4.
- 6 Pass the seat belt through the hole 2 in the backrest casing and remove casing 1.

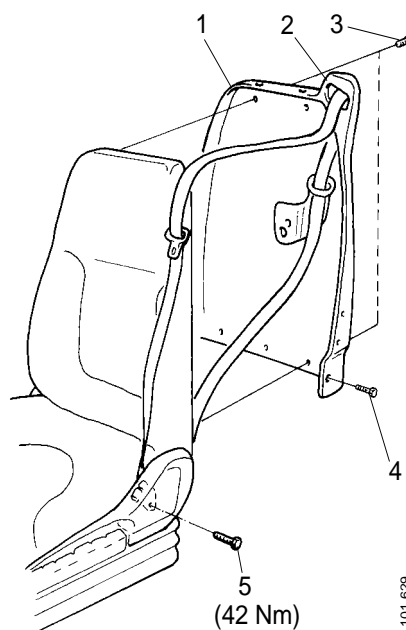

When refitting, use locking fluid on the screws 5 and tighten them to 42 Nm.

Ratchet segment for tilting Medium A

- 1 Remove the seat squab.
- 2 Remove the side casing with the control buttons.
- 3 Unhook the tension springs 3 from parts 7 and 8.
- 4 Remove tension spring 9.
- 5 Remove the screw 2 from the belt retainer 4.
- 6 Remove the screw 5 and nut 1.
- 7 Remove the ratchet segment 6.

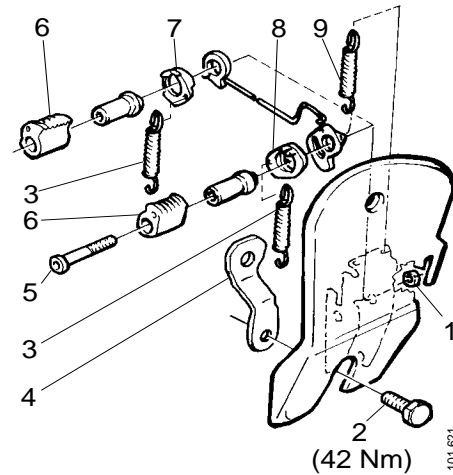

When refitting, use locking fluid on the screw 2 and tighten it to 42 Nm.

A stronger ratchet segment for the upper and lower backrest joints has been fitted as from the following serial number:

- 61 970 056 801

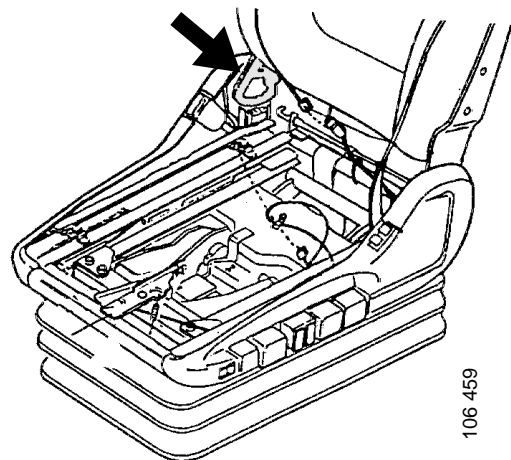

A stronger ratchet segment

Backrest upholstery on Luxury A

Tools

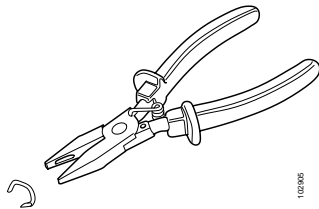
Number	Designation	Illustration	Tool board
588 134	Pliers		None
1 411 488	Staple		None
1 411 487	Clip		None

- 1 Remove the backrest casing.
- 2 Remove the guide casing for the seat belt 1 by removing the screws 2.
- 3 Remove the side casing with the control buttons.
- 4 Remove the retaining screw 6 for the belt.
- 5 Remove the clips 3 from the backrest frame.
- 6 Remove the staples 4.
- 7 Remove the upholstery.

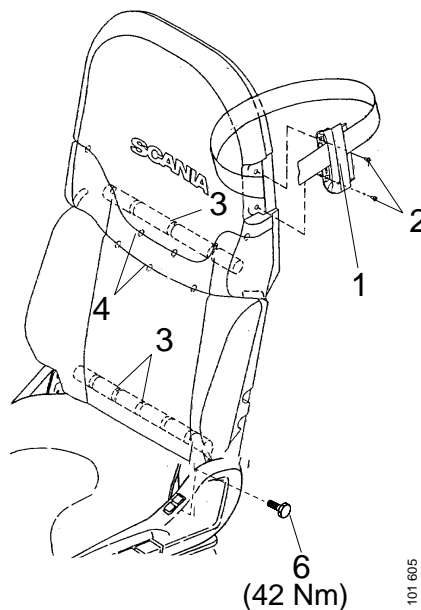

Backrest upholstery on Medium A

Tools

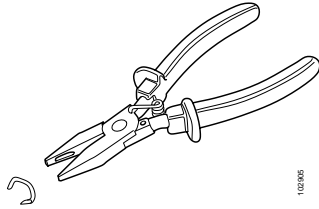
Number	Designation	Illustration	Tool board
588 134	Pliers		None
1 411 488	Staple		None

- 1 Remove the head restraint and the backrest casing.
- 2 Remove the bracket 1.
- 3 Remove the clips 2 and 3.
- 4 Remove the upholstery.

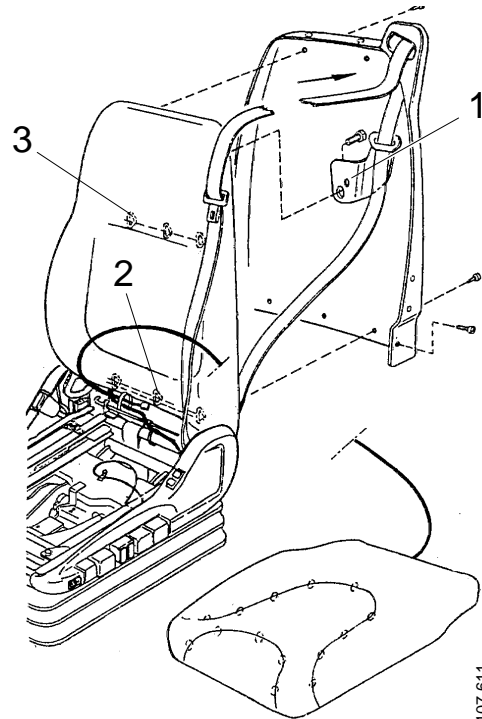

Heater pad in the backrest

- 1 Remove the seat squab.
- 2 Remove the backrest casing.
- 3 Remove the staples from the rear. Fold the upholstery to one side to make the heater pad accessible.
- 4 Method 1: Peel the old heater pad carefully away from the backrest and stick the new pad into place.

Method 2: Cut the cables and the thermostat
2. Stick the new heater pad on top of the old one.

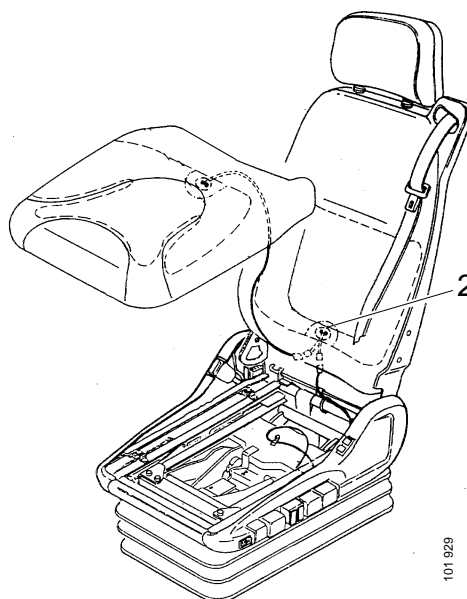

Air cushions for the lumbar support

- 1 Remove the backrest casing.
- 2 Loosen and fold the upholstery to one side.
- 3 Disconnect the air hoses.
- 4 Push the foam rubber to one side. Tap or cut the plastic rivets from the air cushion 1.

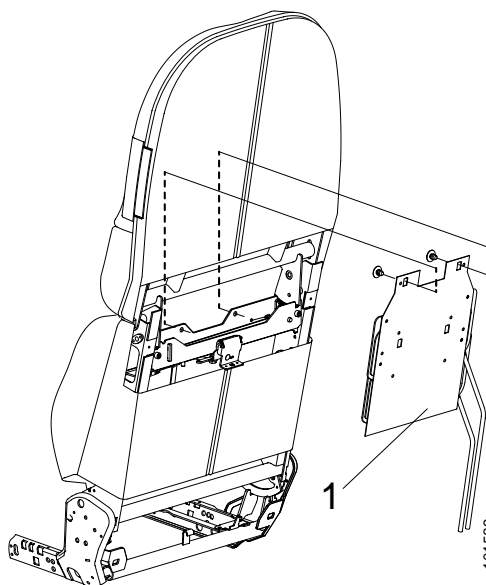

Air cushions for the side supports in Luxury A

- 1 Remove the backrest casing.
- 2 Loosen and fold the upholstery to one side.
- 3 Detach the air hose 1 by the T-piece.
- 4 Detach the air cushion from the plastic locks 2 and the plastic knobs 3.

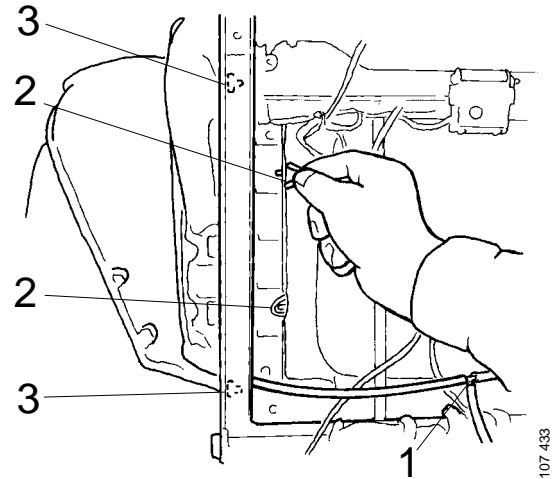

- 5 Transfer the air hose to the new air cushion.

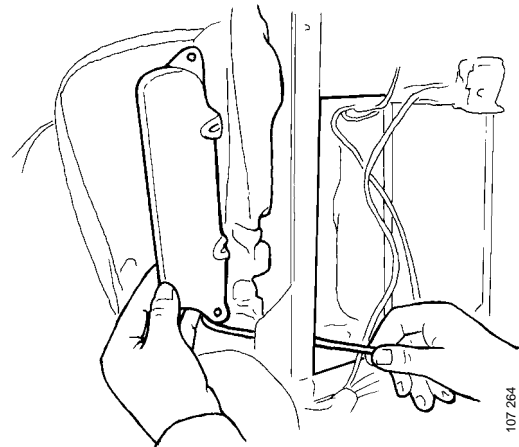

Upper air valve in Luxury A

The upper air valve controls the upper part of the backrest.

If the air cylinders in the seat are leaking, a hissing sound will be heard and the handle for adjusting the backrest will no longer function.

- 1 Tilt the upper part of the backrest forwards 90 degrees.
- 2 Remove the upper backrest casing.
- 3 Remove the tension spring 1 using a pipe approximately 30 cm long with an internal diameter of 8 mm.
- 4 Detach the hexagon screw 3 from the air valve 4.
- 5 Unhook the cylinder from the shaft 2.
- 6 Detach the air connection from the cylinder.

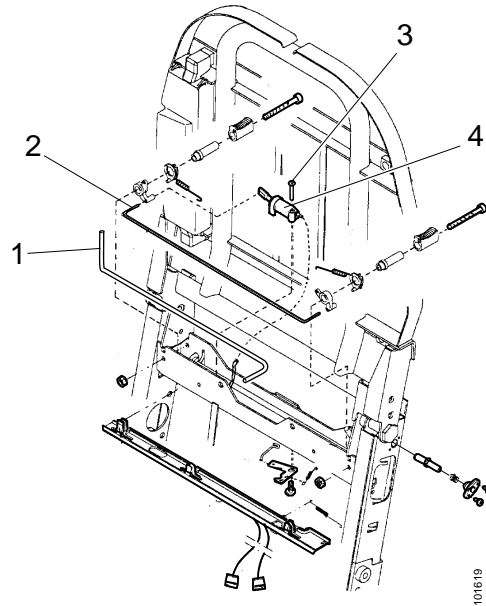

Lower air valve in Luxury A

The lower air valve controls the lower part of the backrest.

If the air cylinders in the seat are leaking, a hissing sound will be heard and the buttons for adjusting the backrest will no longer function.

- 1 Remove the seat squab.
- 2 Remove the screw 1 and change the air valve 2.
- 3 Unhook the cylinder from the shaft 3.
- 4 Disconnect the air connection and change the cylinder.

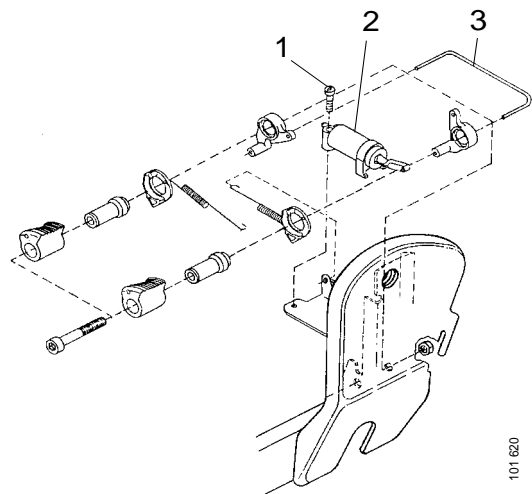

Valve for setting the backrest in Luxury A



WARNING!

Always secure the seat with a block to prevent your limbs from being trapped.

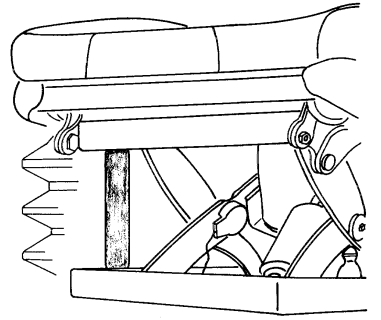

- 1 Remove the seat squab.
- 2 Set the height at the uppermost position and secure with a block.

- 3 Discharge the air from the system.
- 4 Detach the protection boot from the lower part of the seat frame.
- 5 Extract the valve shaft 7 from 4.
- 6 Remove the screw 3 from the valve 1.
- 7 Remove the valve 1 from the seat plate.
- 8 Remove hoses 8, 9 and 2 from the valve 1.

Connect the new valve. Check that it is working by turning screws 5 and 6 until the valve starts to hiss, then screw them a little more until the hissing stops.

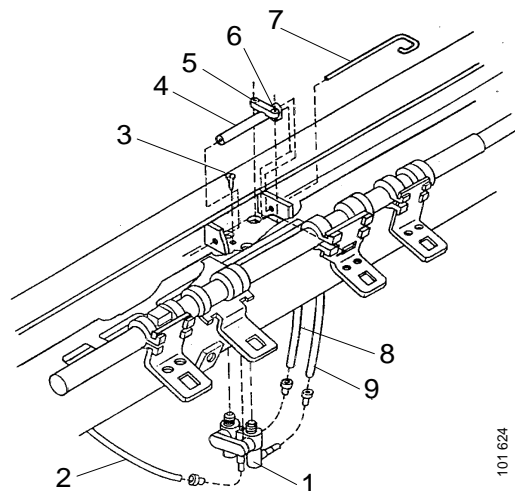

Seats with the following serial numbers have been equipped with a reinforced link:

- 61 960 021 797 - 619 621 797 on left-hand seats;
- 61 960 023 771 - 619 623 771 on right-hand seats.

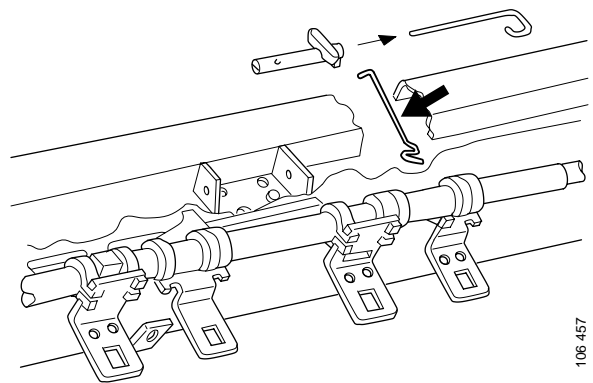

Reinforced link

The valve is not equipped with a link as from the following numbers:

- 61 960 021 797 on left-hand seats;
- 61 960 023 771 on right-hand seats.

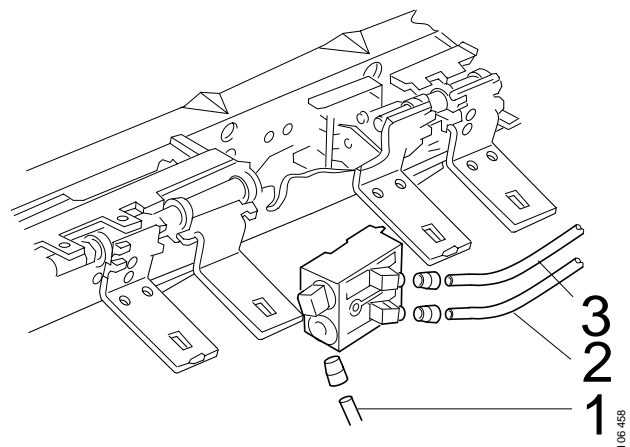

Valve without a link

1 black

2 Red

3 Blue

Seat belt

Seat belt for Luxury A

IMPORTANT! If the belt has been damaged in a road accident, the buckle must be changed as well.

- 1 Remove the upper part of the backrest casing.
- 2 Remove the guide casing for the seat belt 1 by removing the screws 2.
- 3 Fold the upholstery to one side.
- 4 Disconnect the cable 3.
- 5 Remove the screws 4.
- 6 Remove the inertia reel.
- 7 Remove the side casing with the control buttons and remove the rear/lower casing.
- 8 Remove the screw 5 from the belt bracket.

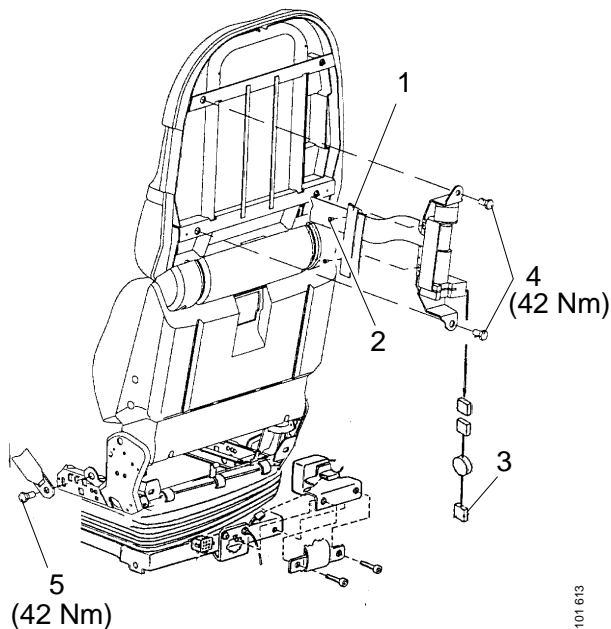

Refit screws 4 and 5 using locking fluid and tighten them to 42 Nm.

Seat belt for Medium A

IMPORTANT! If the belt has been damaged in a road accident, the buckle must be be changed as well.

- 1 Remove the backrest casing.
- 2 Remove the side casing and the rear lower casing.
- 3 Remove the retaining screw 1 from the belt.
- 4 Remove the screw 2 from the inertia reel.

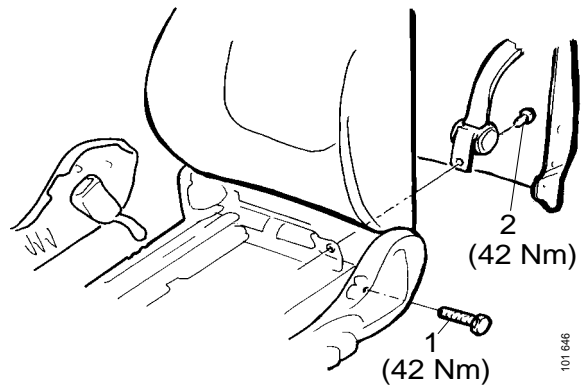

When refitting, use locking fluid on screws 1 and 2 and tighten them to 42 Nm.

Seat belt and belt tightener for Luxury A



WARNING!

Disconnect all power sources from the vehicle before starting work on the belt tightener.

The belt tightener contains a firing charge. Do not perform any other work on it besides that described here.

Carry the belt tightener with the mouth of the pipe pointing downwards. Do not hold your fingers over the pipe mouth or cable.

After removing the belt tightener, place it in its box.

Keep the belt tightener in its box until you fit it into place. If you have to stop work, lock it away safely in a storeroom

Do not use a belt tightener that has fallen more than 0.5 metres on to a hard surface.

IMPORTANT! If the belt has been damaged in a road accident, the buckle must be changed as well.

Removal

- 1 Make sure you have an empty box to put the belt tightener in when you have removed it. If you are going to fit a new belt tightener, use its box for the old one.

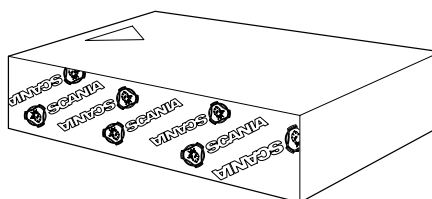

100 000

- 2 Push the upper part of the backrest forward as far as it will go.
- 3 Remove the screws 2 from the handle 1.
- 4 Remove the remaining screws 3 from the casing.

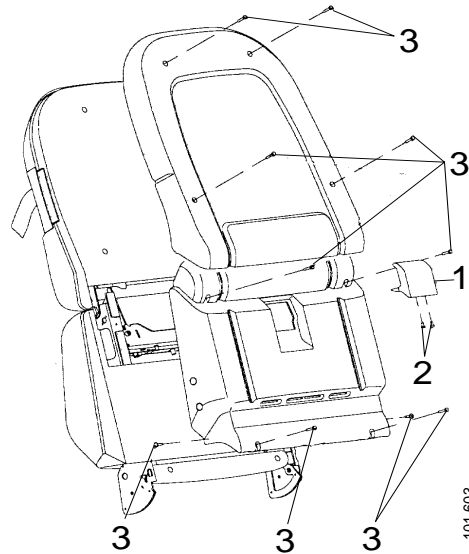

- 5 Remove the guide casing from the seat belt 1 by removing the screws 2.
- 6 Fold the upholstery to one side.
- 7 Disconnect the wiring under the belt tightener.
- 8 Remove the screws 3.
- 9 Remove the inertia reel and firing pipe.

IMPORTANT! Place the belt tightener in a special box.

- 10 Remove the side casing with the control buttons and remove the rear/lower casing.
- 11 Remove the screw 4 from the belt bracket.

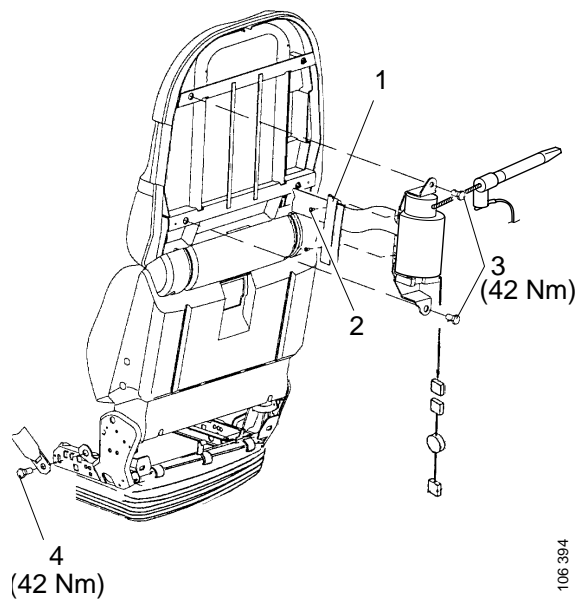

Refitting

- 1 Refit the screw 4 using locking fluid and tighten it to 42 Nm.
- 2 Refit the side casing with the control buttons, and the rear/lower casing.
- 3 Refit the inertia reel and firing pipe. Apply locking fluid to the screws 3 and tighten them to 42 Nm.
- 4 Reconnect the wiring.
- 5 Fold the upholstery back into place.
- 6 Refit the guide casing for the seat belt 1 with the screws 2.

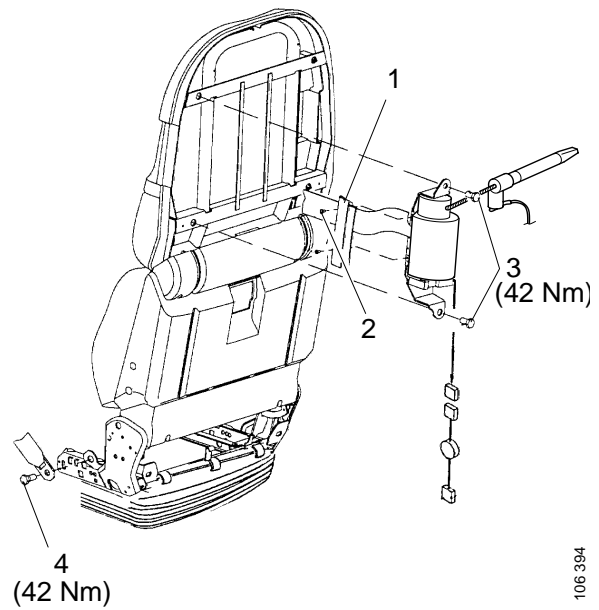

106 394

- 7 Refit the backrest casing.

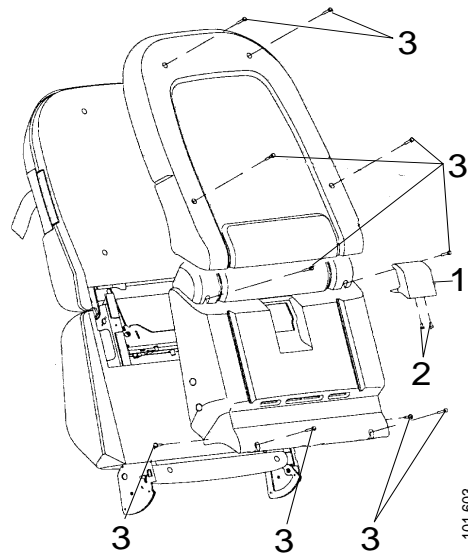

101 603

Seat belt and belt tightener for Medium A

The following illustrations show the position of the seat-belt tightener in the Medium A.



WARNING!

Disconnect all power sources from the vehicle before starting work on the belt tightener.

The belt tightener contains a firing charge. Do not perform any other work on it besides that described here.

Carry the belt tightener with the mouth of the pipe pointing downwards. Do not hold your fingers over the pipe mouth or cable.

After removing the belt tightener, place it in its box.

Keep the belt tightener in its box until you fit it into place. If you have to stop work, lock it away safely in a storeroom

Do not use a belt tightener that has fallen more than 0.5 metres on to a hard surface.

IMPORTANT! If the belt has been damaged in a road accident, the buckle must be changed as well.

Removal

- 1 Make sure you have an empty box to put the belt tightener in when you have removed it. If you are going to fit a new belt tightener, use its box for the old one.

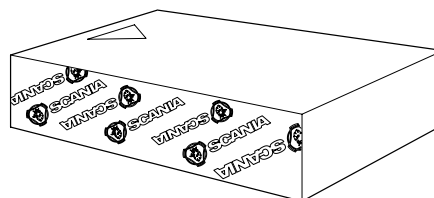

- 2 Remove the backrest casing.
- 3 Remove the side casing and the rear lower casing.
- 4 Remove the retaining screw 1 from the belt.
- 5 Disconnect the wiring.
- 6 Remove the screw 2 from the inertia reel.

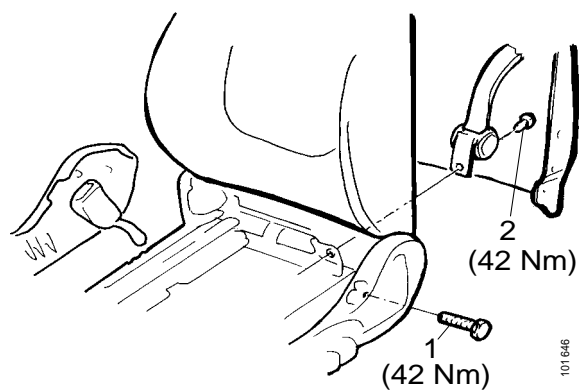

- 7 Remove the inertia reel.

IMPORTANT! Place the belt tightener in a special box.

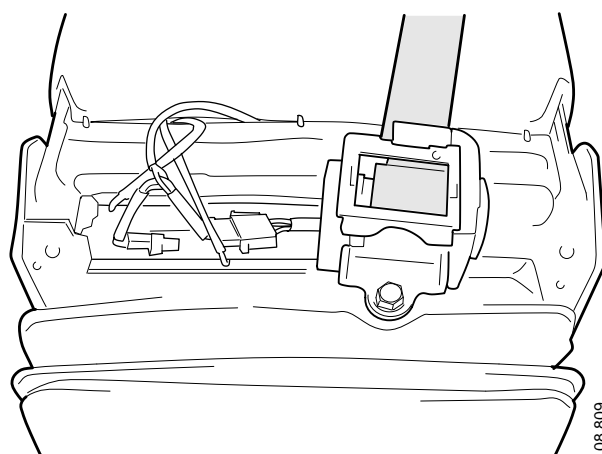

When refitting, use locking fluid on screws 1 and 2 and tighten them to 42 Nm.

Buckle

- 1 Remove the side casing without the control buttons.
- 2 Remove the buckle 1 and screw 2.

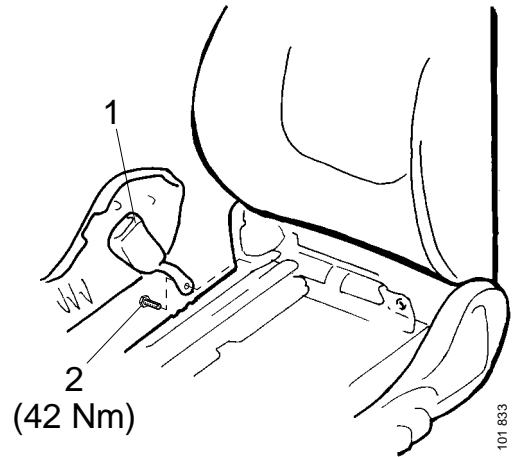

When refitting, use locking fluid on the screw 2 and tighten it to 42 Nm.

Belt switch in Luxury A

- 1 Remove the connector 3 from its retainer.
- 2 Remove the screws 2.
- 3 Lift up the protection boot.
- 4 Remove the contact 1 and cut the strap.

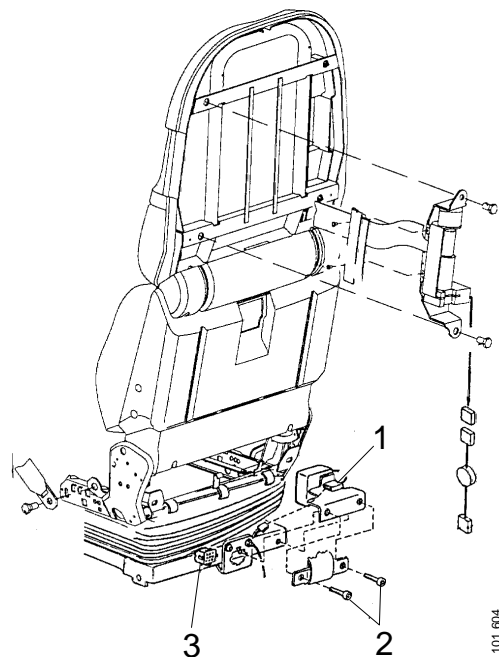

Seats for the US market

The following applies to seats that have been adapted to comply with regulations in the United States. A belt passes from the rear of the backrest to a bracket in the cab wall. The bracket is located behind the wardrobe wall.

When refitting, use locking fluid on the screws and tighten them as per the torque in the illustrations.

Belt in the backrest

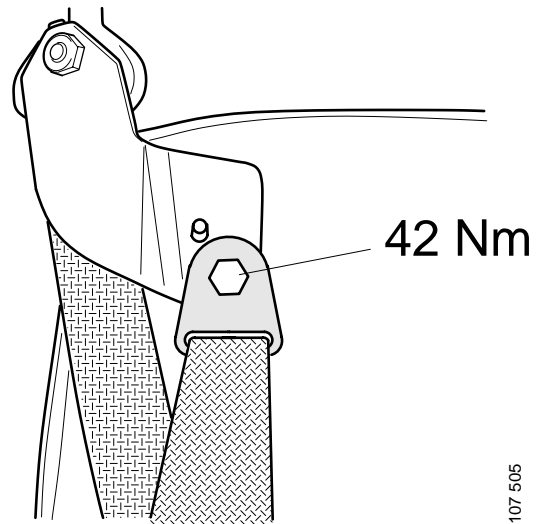

107 505

Belt in the cab wall

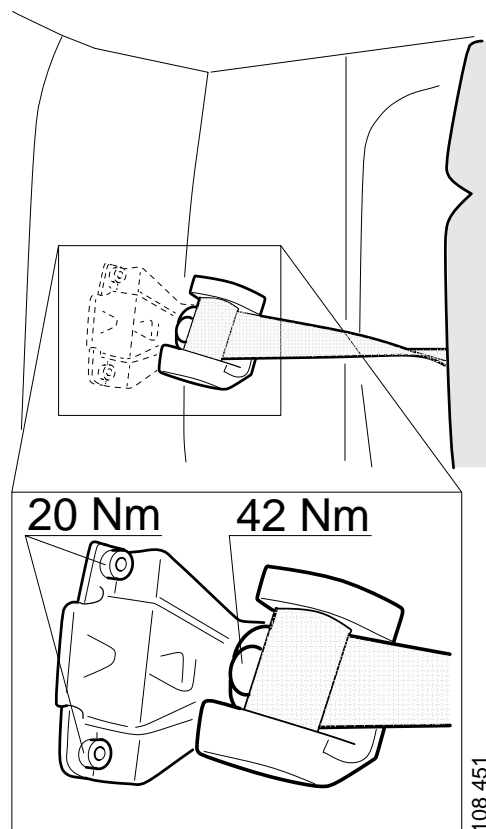

108 451

Shock absorber and cable

Shock absorber



WARNING!

Always secure the seat with a block to prevent your limbs from being trapped.



- 1 Remove the seat.
- 2 Remove the seat squab.
- 3 Remove lock plates 2 and 5.
- 4 Move the seat by hand to the uppermost position and secure it into place with a block.
- 5 Discharge the air.
- 6 Detach the protection boot from the front of the seat.
- 7 Unscrew the screw 3 and remove the shock absorber 4.
- 8 Remove the cable from the holder 1.

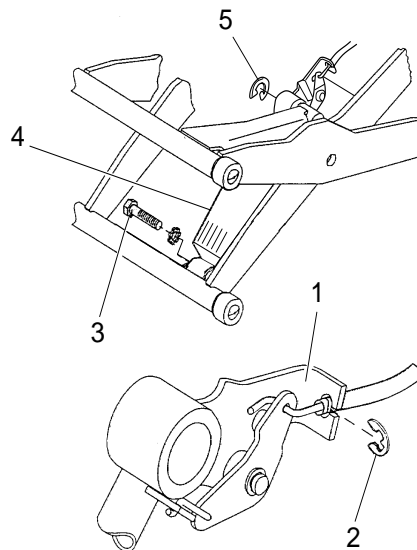

Cable for setting the shock absorber

- 1 Remove the seat squab.
- 2 Remove the screw 9.
- 3 Remove the lock plate 7.
- 4 Remove the cable 6 from the shock absorber.
- 5 Remove the bracket 4 from the frame 5.
- 6 Remove the bracket 2 from the button 1. Push the cable out from under the button. Detach the bracket from the cable.

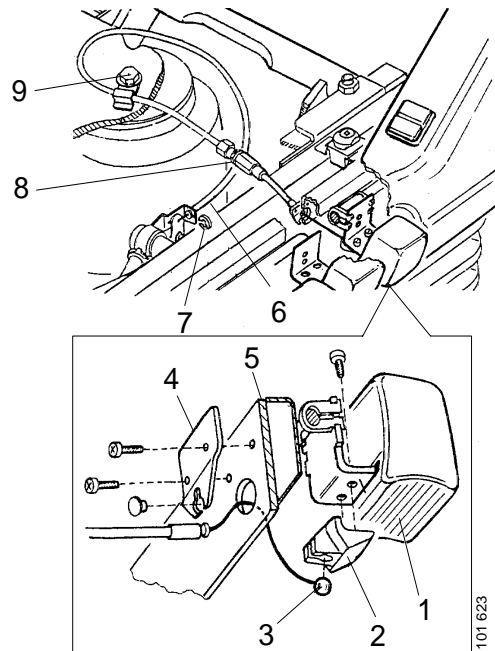

When fitting a new cable, grease the ball 3 before placing it in the bracket 2.

Note: Checking the position of the soft/hard absorption setting: if full shock is not attained, adjust the setting screw 8.

Gas spring and cable

Gas spring in Medium A



WARNING!

Always secure the seat with a block to prevent your limbs from being trapped.

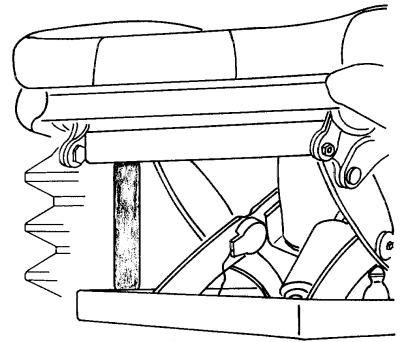

- 1 Remove the seat.
- 2 Remove the seat squab.
- 3 Lower the seat as far as it will go.
- 4 Remove the lock plate 1.
- 5 Detach the cable 2.

Note: Do not touch the button.

- 6 Remove nuts 3 and 4.
- 7 Push the front of the seat upwards until the gas spring falls out of its bracket.

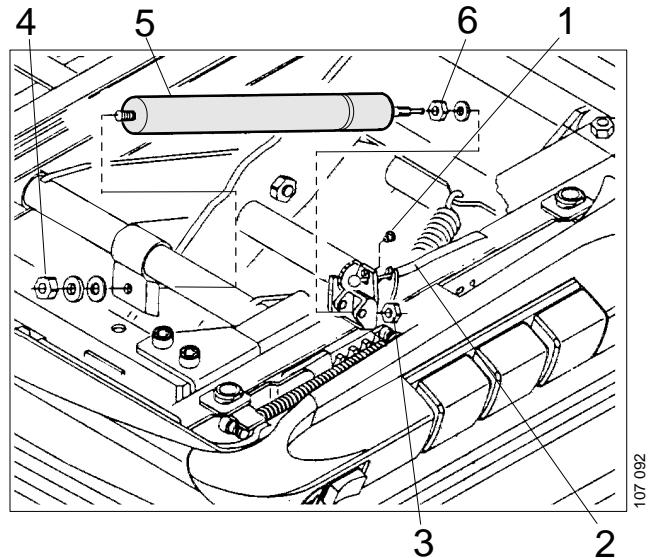

When fitting a new gas spring, refit the nut 6 and plate first. Adjust the nut between the gas spring and nut 3. Use the nut on the old gas spring.

Test to see if the gas spring is working. If not, see *Cable for the gas spring*.

Cable for the gas spring in Medium A



WARNING!

Always secure the seat with a block to prevent your limbs from being trapped.

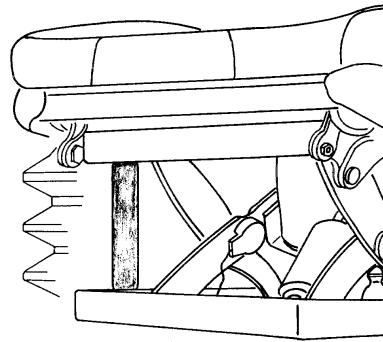

101 628

- 1 Remove the seat squab.
- 2 Remove lock plates 1 and 3.
- 3 Detach the cable 2 from the bracket.

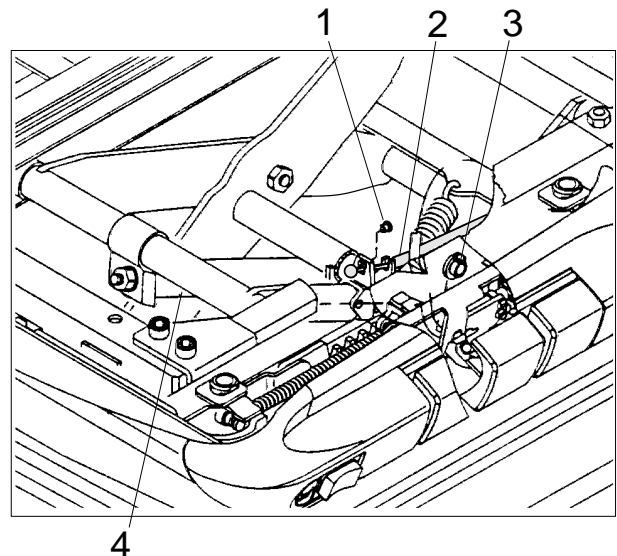

107 091

After fitting the new cable, test the height adjustment function. If it is not working or blocked, adjust the length of the cable.

- 4 Tighten the lock nuts after each adjustment of the cable.

Air spring

Air spring



WARNING!

Always secure the seat with a block to prevent your limbs from being trapped.

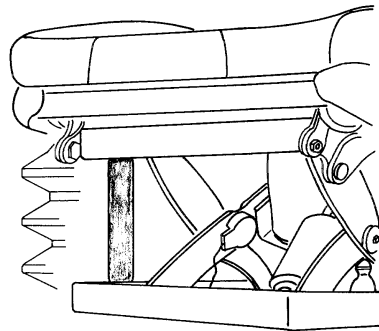

- 1 Remove the seat.
- 2 Move the seat by hand to its uppermost position and secure it with a block.

- 3 Remove the seat squab.
- 4 Remove screws 1 and 2.
- 5 Detach the air hoses and remove the air spring 3.

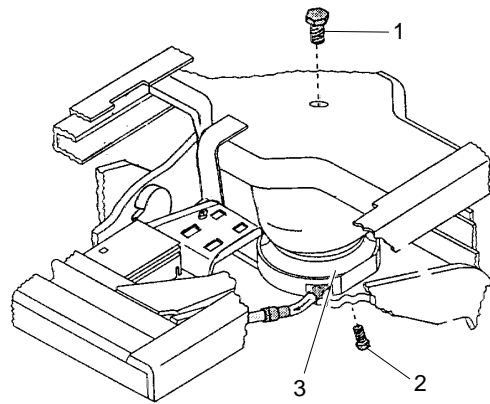

When refitting, make sure that the air hoses do not become trapped and the air spring twisted.

Electronic parts

Control unit



WARNING!

Always secure the seat with a block to prevent your limbs from being trapped.



- 1 Remove the seat squab.
- 2 Set the height adjustment at the highest position.
- 3 Tilt the front of the seat as high as it will go and secure it with a block.

- 4 Remove the front plastic casing.
- 5 Remove the connector 1 from the control unit 4.
- 6 If the control unit is malfunctioning, this could be due to oxidation on the connector pins. If so, remove the connector and then refit it again.
- 7 Remove the retaining nut 2.
- 8 Remove the retaining screws 3.

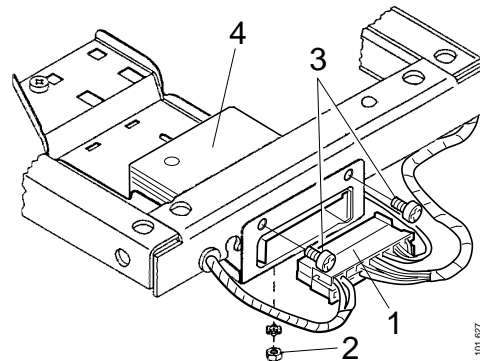

9 Remove the control unit.

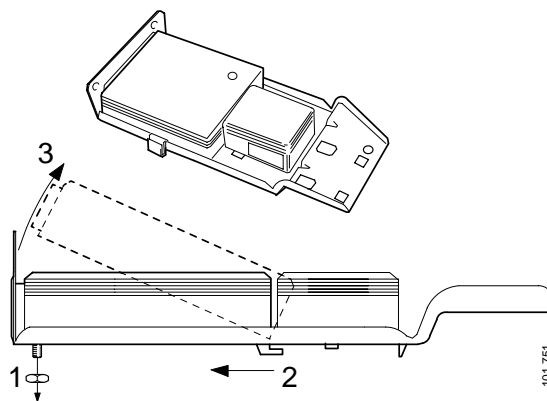

Fit the new control unit into place and tighten the screws to 1.5 Nm.

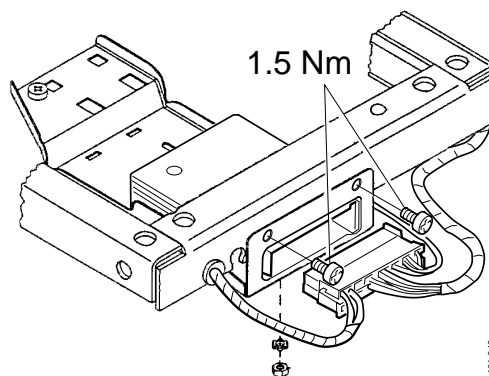

Solenoid valve

- 1 Remove the seat squab.
- 2 Detach the contact 1.

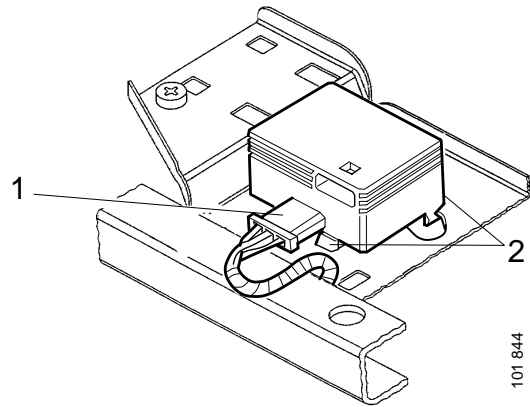

- 3 Pinch clip 2 and carefully remove the air connection under the solenoid valve.
- 4 Pinch clip 4 and remove the solenoid valve 3.

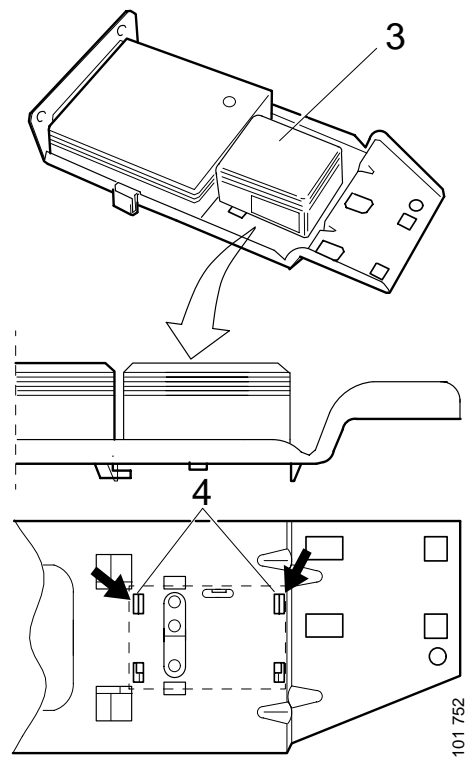

Potentiometer

- 1 Remove the seat squab.
- 2 Set the height adjustment function at its lowest position.
- 3 Detach the cable 2 from the potentiometer 1.
- 4 Fit a new potentiometer on to pin 5.
- 5 Turn the potentiometer until guide pin 6 slots into position 4.
- 6 Press the fastener 3 until it locks.

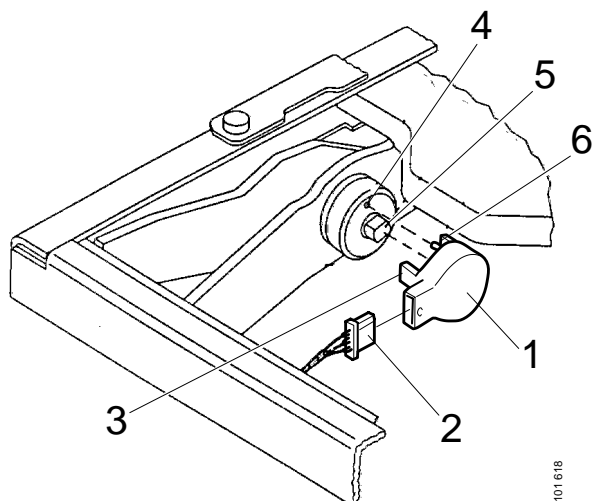

*Up to and including serial number
6 195 242 796*

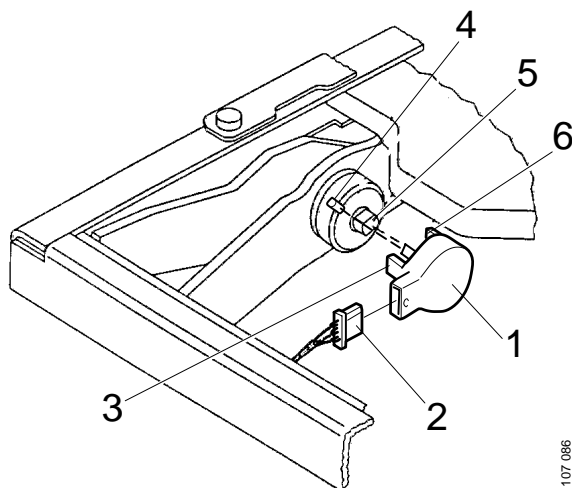

As from serial number 6 195 242 797