

**SCANIA**

**18:05-03**

Issue 1 en

# Eberspächer D1LCC auxiliary heater

## Function and work description

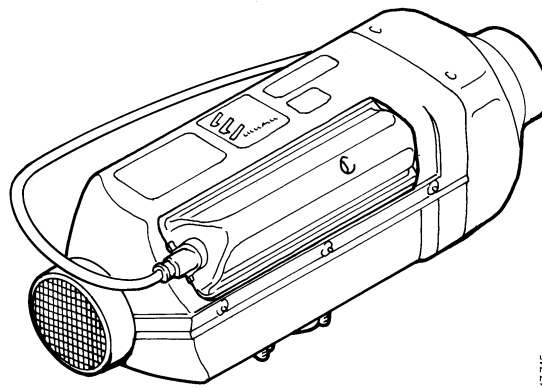

**Reading fault codes: Refer to group 18, Auxiliary heater, Operation unit CTT, D1LC and D1LCC.**

**For wiring diagrams, refer to group 16, Eberspächer D1LCC auxiliary heater**

# Contents

General	.....	3
	ADR .....	3
Function description	Operation unit CTT.....	4
	Engaging .....	4
	Control during operation.....	5
	Activation of cab fan.....	5
	Disengaging .....	6
	Control and safety functions .....	7
Work Description	Specifications.....	9
	Checks in case of malfunction .....	12
	Location of heater .....	13
	Exploded view drawing .....	14
	Removing protection covers .....	15
	Renewing glow plug .....	16
	Renewing control unit.....	17
	Renewing overheat sensor .....	18
	Renewing flame monitor.....	19
	Renewing combustion air fan .....	20
	Renewing gaskets in heat exchanger .....	21
	Measuring fuel volume .....	22
	Internal wiring diagram .....	23

# General

For reading fault codes, refer to group 18, Auxiliary heater Control unit CTT, Function description and reading fault codes.

For wiring diagram, refer to group 16, Eberspächer D1LCC auxiliary heater, 16:24-16.

The following points differ between the D1LCC and D1LC heaters:

- new electrical system
- control unit integrated in the heater
- control unit contains ADR functions. An additional control unit is not required on ADR vehicles.

The heater control unit is a special Scania version that has been introduced to retain the present functions together with the Scania CTT.

The heater is located under the rear centre cover. The heater is fitted to a mounting plate on the rear cab wall. The exhaust system and the air intake are outside the rear cab wall.

## ADR

The internal cable harness and the control unit of the heater are prepared for ADR.

Additional components required when connecting ADR are one relay, one switch on the instrument panel and another cable harness in the instrument panel.

## Function description

### Operation unit CTT

Operation unit CTT is used for switching the heater on and off and for setting the desired cab temperature within the range 10 to 30°C. The heat symbol acts as a function test.

The operating unit can be used to program three starting times per day and the operating time.

### Engaging

The heat symbol will go on in the control unit CTT when the heater is started. The glow plug ignites and the fan starts at low speed.

Fuel supply will start after 15-40 seconds. The air and fuel supply is continuously increased.

The glow plug will go out again once the flame is burning normally and combustion has stabilised.

The heater will start in cold air operation if it has recently been used and the heat exchanger is still warm.

The heater has four different output settings:

- Power
- High
- Medium
- Low

The heater is warmed up in "POWER" mode with full heat until the heat exchanger has reached operating temperature.

The length of time that the maximum heating mode "POWER" is engaged depends on the ambient temperature.

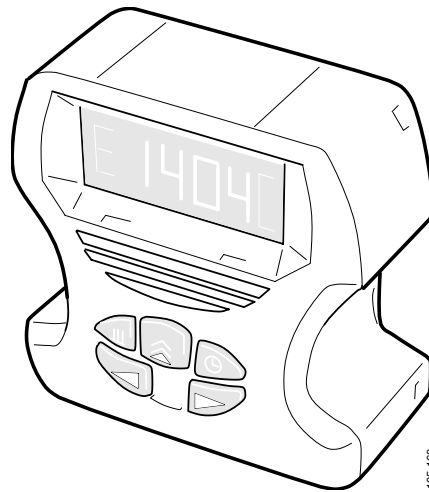

## Control during operation

The temperature of the intake air is continuously measured during heater operation and compared with the desired value in the operating unit. If the temperature is higher than the desired cab temperature, the heater will switch to "LOW" mode and continue to operate at low fan speed.

If the heater output is not sufficient in the "LOW" mode, the heater will switch to the "MEDIUM" mode. The fan will then continue at low speed. In most cases, the LOW-MEDIUM-LOW adjustment will be sufficient to satisfy most heat requirements.

If the heater output in the "MEDIUM" mode is not sufficient, the heater will switch to the "HIGH" mode and the fan motor will start to operate at maximum speed.

Whenever less heat is required than that obtained in the "LOW" mode, the heater will switch to "OFF" and combustion is temporarily interrupted.

It will restart in the "MEDIUM" mode and at low fan speed.

## Activation of cab fan

When the heater switches to the "LOW" mode, the cab fan will automatically be activated at low speed to ventilate the cab.

The cab fan is activated by a voltage signal from the heater control unit, pin 2, when it switches down to the "LOW" mode. This signal controls relays R30 and R31 so that the cab fan starts.

### **Disengaging**

After turning off the heater, the heat symbol will go out at the same time as the fuel supply is switched off. The fan will continue to operate for a while for cooling purposes.

The glow plug is engaged for 30 seconds during the cooling period in order to remove combustion residue.

The heater is switched off immediately without any cooling if there is no fuel supply during start or if the heater is in the "OFF" mode.

## Control and safety devices

The flame is monitored by the flame monitor and the maximum temperature is monitored by the overheat sensor.

Both influence the control unit, which turns off the auxiliary heater in the event of malfunctions.



**WARNING!**

**The heater must not be used in garages or other indoor locations.**

**IMPORTANT!** When electric or MIG welding, the positive connection on the battery must be removed and connected to earth to protect the control unit.

**IMPORTANT!** The auxiliary heater must always be turned off when refuelling.

The heater will be disengaged if any of the following malfunctions occur:

- the heater does not ignite within 2 x 90 seconds after the fuel supply has started, i.e. two start attempts.
- the heater starts but is extinguished within 10 minutes
- the heater becomes overheated, activating the overheat sensor and cutting off the fuel supply
- the voltage drops below 21 V or rises above 32 V
- the glow plug is defective or there is a break in the electrical cable to the dosage pump
- the fan motor does not work when starting.

During operation, the fan motor is monitored every 4 minutes. The heater will be disengaged due to malfunction if the motor speed drops below the permitted limit.

Disengagement due to a malfunction can be cancelled by disengaging and engaging again.

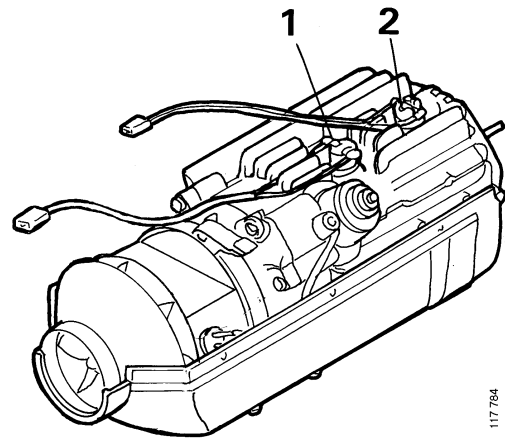

- 1 Overheat sensor
- 2 Flame monitor

117784





# Work Description

## Specifications

### Technical data

Heating medium	Air
Heater output levels	High, Medium, Low and Off
Fuel	Diesel
Rated voltage	24 V
Lower voltage limit*	21 V, 19 V with lit glow plug.
Upper voltage limit*	32 V, 30.4 V with ignited glow plug.
Degree of radio interference suppression	3, further suppression is possible.
Weight	approximately 3.5 kg
Power consumption on starting**	210 W

\* Voltages must be attained for more than 20 seconds.

\*\* At rated voltage, all data +/- 10%.

	<b>Power</b>	<b>High</b>	<b>Medium</b>	<b>Low</b>
Heating capacity**	2200 W	1800 W	1200 W	850 W
Power consumption in operation**	30 W	22 W	10 W	8-10 W
Warm air flow without counter pressure**	110 kg/h	95 kg/h	65 kg/h	65 kg/h
Fuel consumption**	0.27 l/h	0.21 l/h	0.14 l/h	0.10 l/h
Fan speed, check value	5500 rpm	4400 rpm	3000 rpm	2300 rpm

\*\* At rated voltage, all data +/- 10%.

### **Description**

### **Activating range**

Overheat sensor

160°-185°C

### **Exhaust values**

CO, high mode.

7-11 % by vol.

Bacharach soot rating

< 2

Resistance values

**Description**

**Ohms**

Dosage pump

approximately 36 Ohms

Glow plug

approximately 2 Ohms

- Diagram for measuring resistance of flame monitor or overheat sensor.

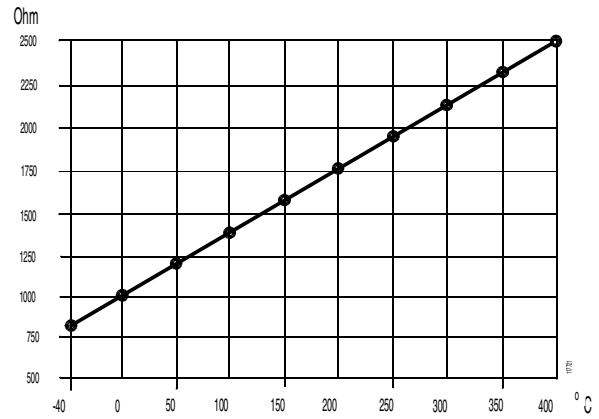

*Diagram for flame monitor and overheat sensor*

- Diagram for measuring resistance of temperature sensor.

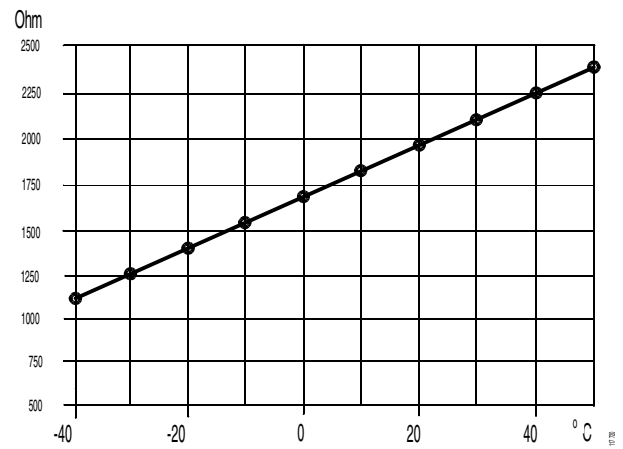

*Diagram for temperature sensor*

## Checks in case of malfunction

Check the following points in case of a heater malfunction:

- short circuits, breaks in cables or incorrect connection
- corroded terminals
- fuses
- electric cables, connectors and terminals
- battery voltage when starting the heater
- mechanical damage to components
- fuel level in tank
- intake air and exhaust lines
- warm air line and intake grille
- when switching to winter operation: is there summer diesel remaining in the lines.

**Note:** The glow plug strainer should be checked annually and renewed if damaged.

**IMPORTANT!** Always check part numbers when renewing components.

## Location of heater

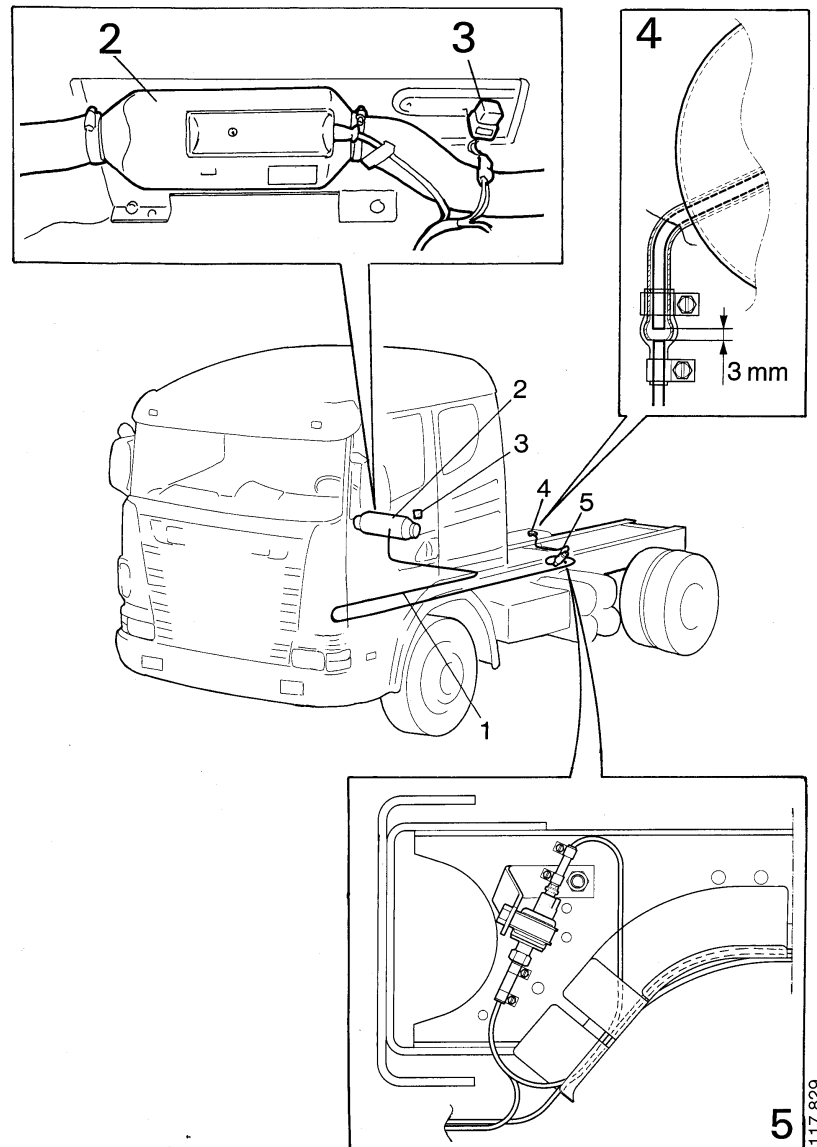

### 1 Fuel pipe

- Always cut the fuel pipe with a knife. Never pinch it off. Cut the ends straight and make sure they retain their circular form.
- The fuel pipe is clamped to the floor of the cab together with the brake pipe to the dosage pump.

### 2 D1LCC auxiliary heater

- The heater is fitted to a mounting plate on the rear cab wall.

### 3 ADR relay R67

- One relay and a different cable harness in the instrument panel are required for ADR.

### 4 Tank connection

### 5 Dosage pump

Exploded view drawing

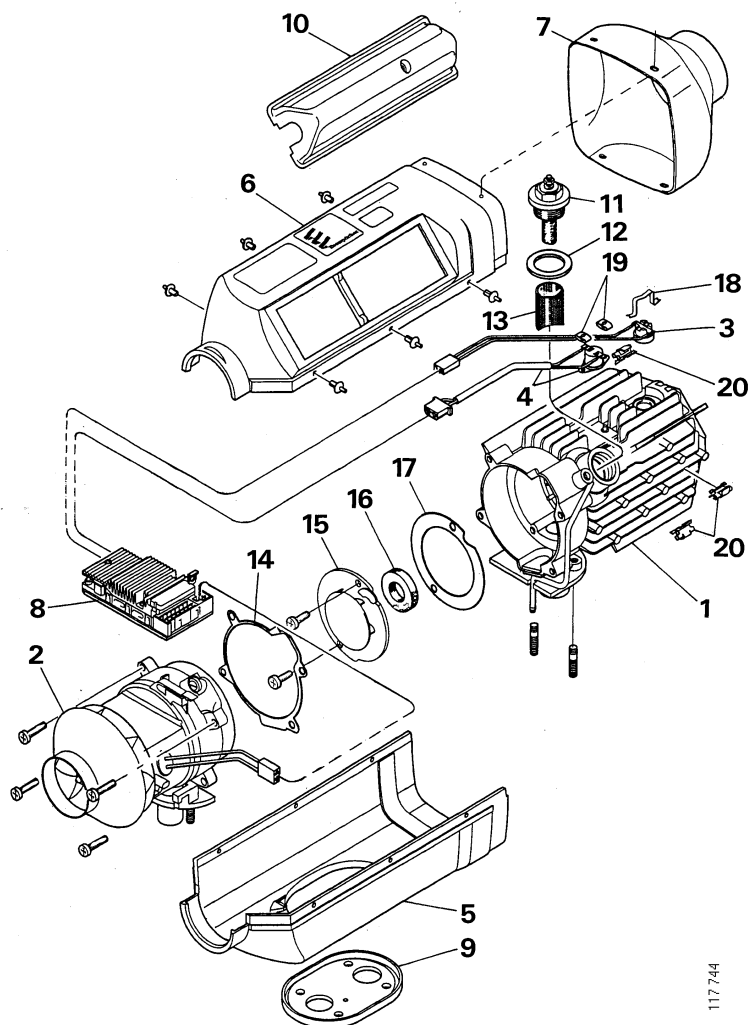

117 744

- 1 Heat exchanger
- 2 Fan
- 3 Flame monitor
- 4 Overheat sensor
- 5 Lower jacket section
- 6 Upper jacket section
- 7 Exhaust cowl
- 8 Control unit
- 9 Flange gasket
- 10 Cover

- 11 Glow plug
- 12 Gasket
- 13 Glow plug strainer
- 14 Gasket
- 15 Cover
- 16 Gasket
- 17 Gasket
- 18 Clamp
- 19 Retainers
- 20 U-clip

## Removing protection covers

### Removing cover

- 1 Undo the internal hexagon screw and remove the cover.

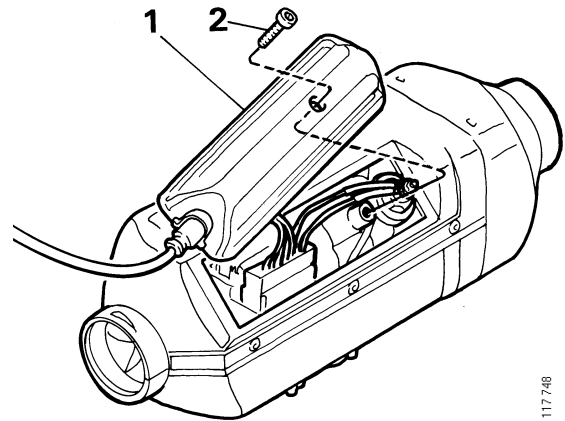

117 748

- 1 Cover
- 2 Internal hexagon screw

### Removing the exhaust cowl

- 1 Remove the exhaust cowl with a screwdriver.

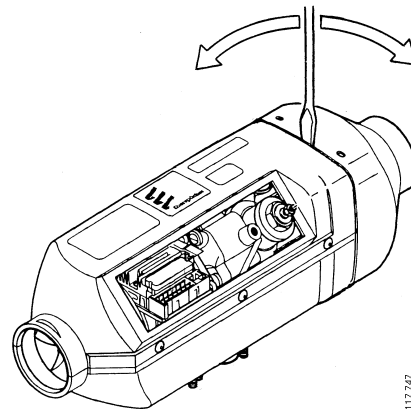

117 747

*Exhaust cowl*

### Removing jacket sections

- 1 Remove the expansion rivets with a small drift and a knife.
- 2 Remove the jacket sections.

Use new expansion rivets when assembling.

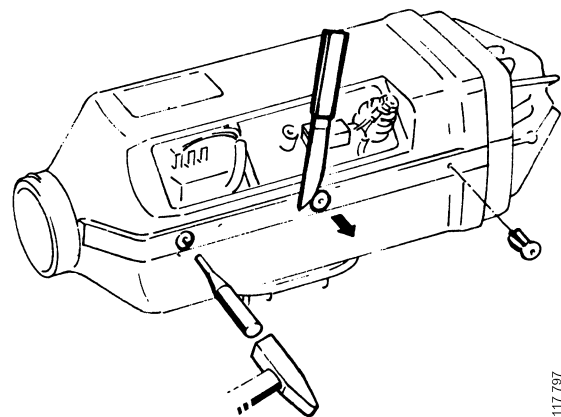

117 797

## Renewing glow plug

**IMPORTANT!** Always check part numbers when renewing this component as different glow plugs are available.

**Note:** Also renew glow plug strainer and washer together with the glow plug.

- 1 Remove the cover.
- 2 Remove the connector from the control unit.
- 3 Remove the nut from the glow plug connector.
- 4 Remove the connector and screw out the glow plug.
- 5 Remove the glow plug strainer with a pair of pointed pliers.
- 6 Carefully slide in the new glow plug strainer as far as possible.

**IMPORTANT!** The glow plug vent hole must be free from dirt.

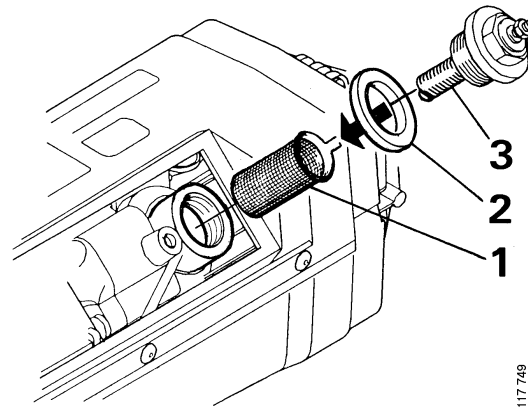

117 749

- 1 *Glow plug strainer*
- 2 *Washer*
- 3 *Glow plug*

- 7 Make sure the tongue and groove are aligned correctly when fitting the new strainer.

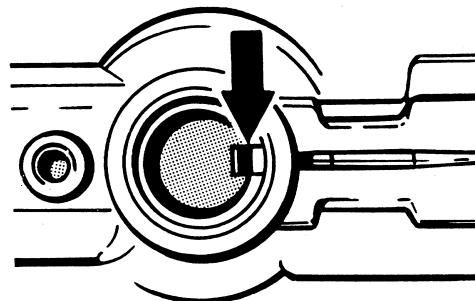

117 750



## Renewing control unit

**IMPORTANT!** Check the part number when renewing the control unit, as the control unit is specific to Scania with operating unit CTT.

- 1 Remove the cover.
- 2 Remove both connectors from the control unit.
- 3 Release the catch for the control unit and pull it out of the grooves.
- 4 Then unplug both connectors on the back of the control unit.

Fit the control unit in reverse order.

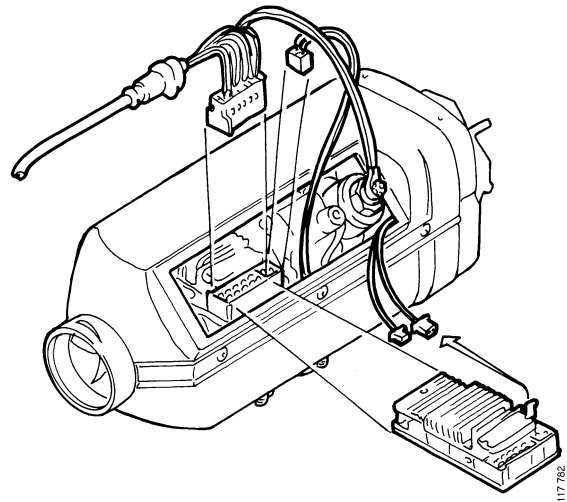

## Renewing overheat sensor

- 1 Remove the cover, the exhaust cowl and the jacket sections.
- 2 Remove the overheat sensor connector from the control unit.

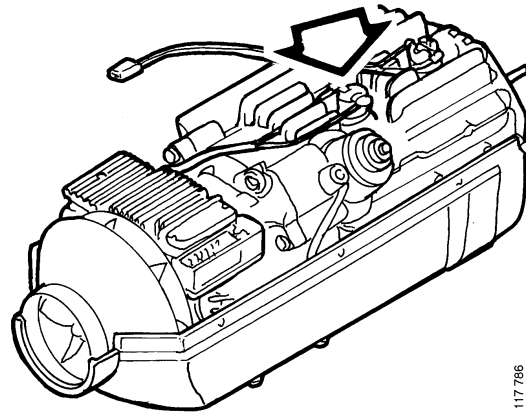

*Overheat sensor*

- 3 Remove the safety clips and the overheat sensor.

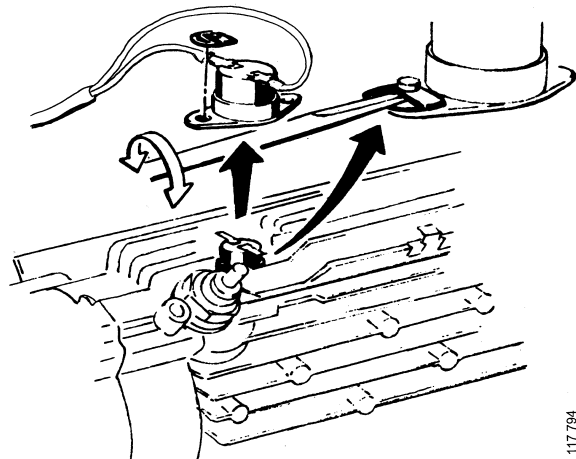

- 4 Use new safety clips when refitting.

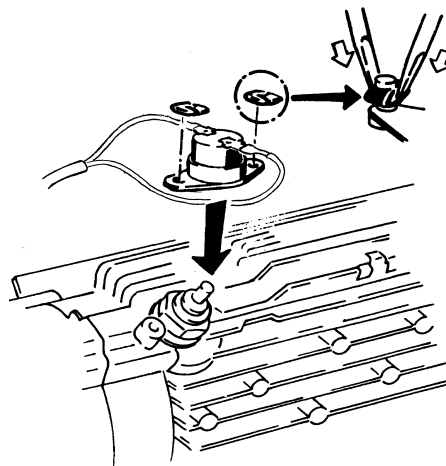

## Renewing flame monitor

- 1 Remove the cover, the exhaust cowl and the jacket sections.
- 2 Remove the connector from the control unit.

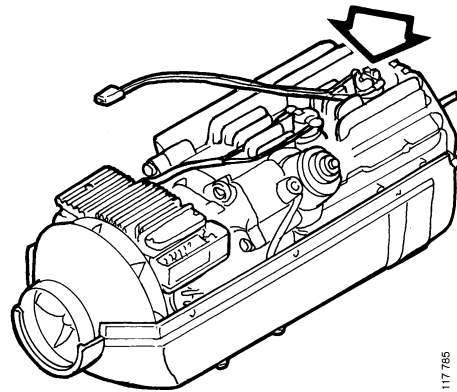

117 785

*Flame monitor*

- 3 Remove the clamp and the flame monitor.

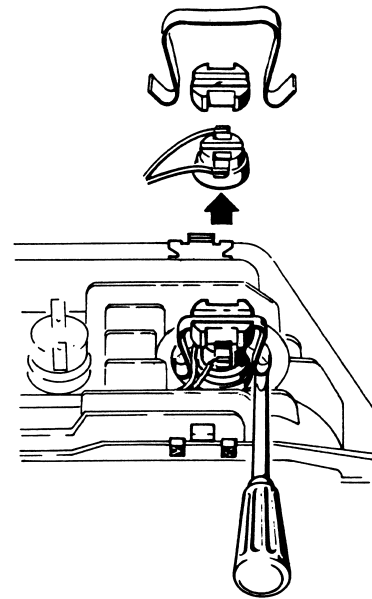

117 783

Assemble in reverse order.

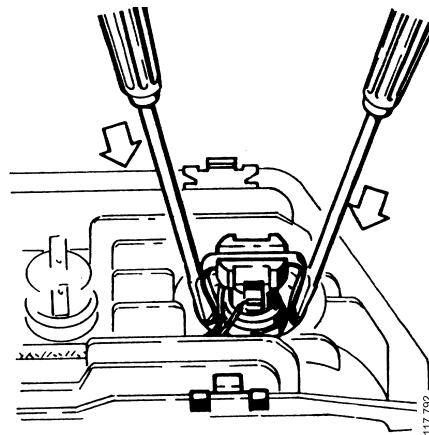

117 782

## Renewing combustion air fan

- 1 Remove the cover, the exhaust cowl and the jacket sections.
- 2 Remove the connectors for the overheat sensor and the flame monitor from the control unit.
- 3 Remove the control unit.
- 4 Unscrew the four screws on the combustion air fan.
- 5 Remove the combustion air fan and the gasket from the heat exchanger.
- 6 Renew the gasket and assemble in reverse order.

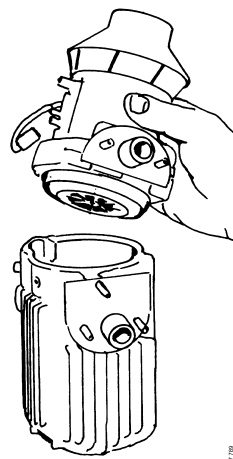
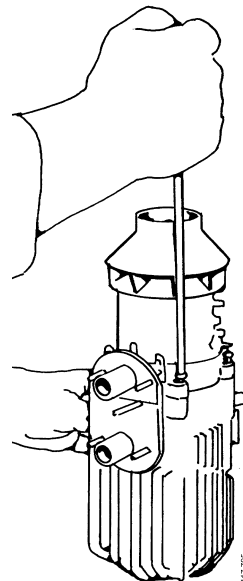

## Renewing gaskets in heat exchanger

- 1 Remove the cover, the exhaust cowl and the jacket sections.
- 2 Remove the control unit.
- 3 Remove the combustion air fan.
- 4 Remove the screws and remove the heat exchanger cover.

Renew the gaskets and assemble in reverse order.

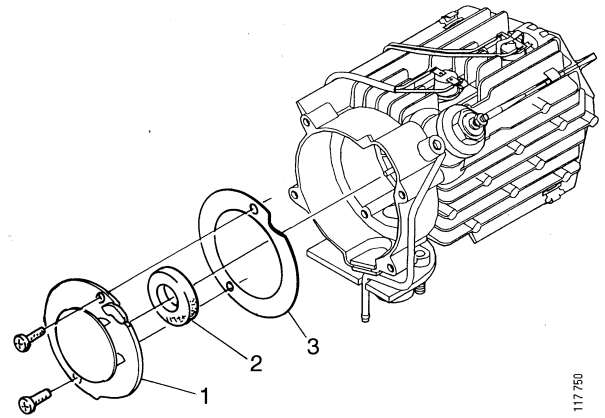

- 1 *Cover*
- 2 *Gasket*
- 3 *Gasket*

117750

## Measuring fuel volume

### Preparations

- 1 Detach the fuel line from the heater.
- 2 Insert the line into a measuring glass with a volume of 10 cm<sup>3</sup>.
- 3 Start the heater.
- 4 Wait until the dosage pump starts to feed fuel.
- 5 If the flow of fuel is even and there are no bubbles then the fuel line contains only fuel and no air.
- 6 Turn off the heater and empty the measuring glass.

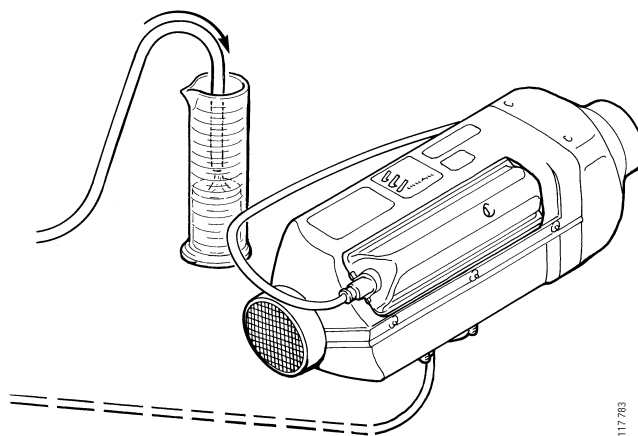

### Measuring

- 1 Start the heater.
- 2 Wait until the dosage pump starts to feed fuel.
- 3 Hold the measuring glass level with the glow plug while measuring.
- 4 Turn off the heater when 90 seconds has expired and the fuel pump has stopped, otherwise it will be restarted automatically.
- 5 Read off the fuel volume in the measuring glass.
- 6 Compare with the value in the table.
- 7 Fuel consumption is correct when the value is between the minimum and maximum values shown in the table.
- 8 The dosage pump must be renewed if the value is outside these limits.

### D1LCC

Nominal value

Maximum value

Minimum value

### Fuel consumption during 90 seconds

4.0 cm<sup>3</sup>

4.7 cm<sup>3</sup>

3.4 cm<sup>3</sup>

# Internal wiring diagram

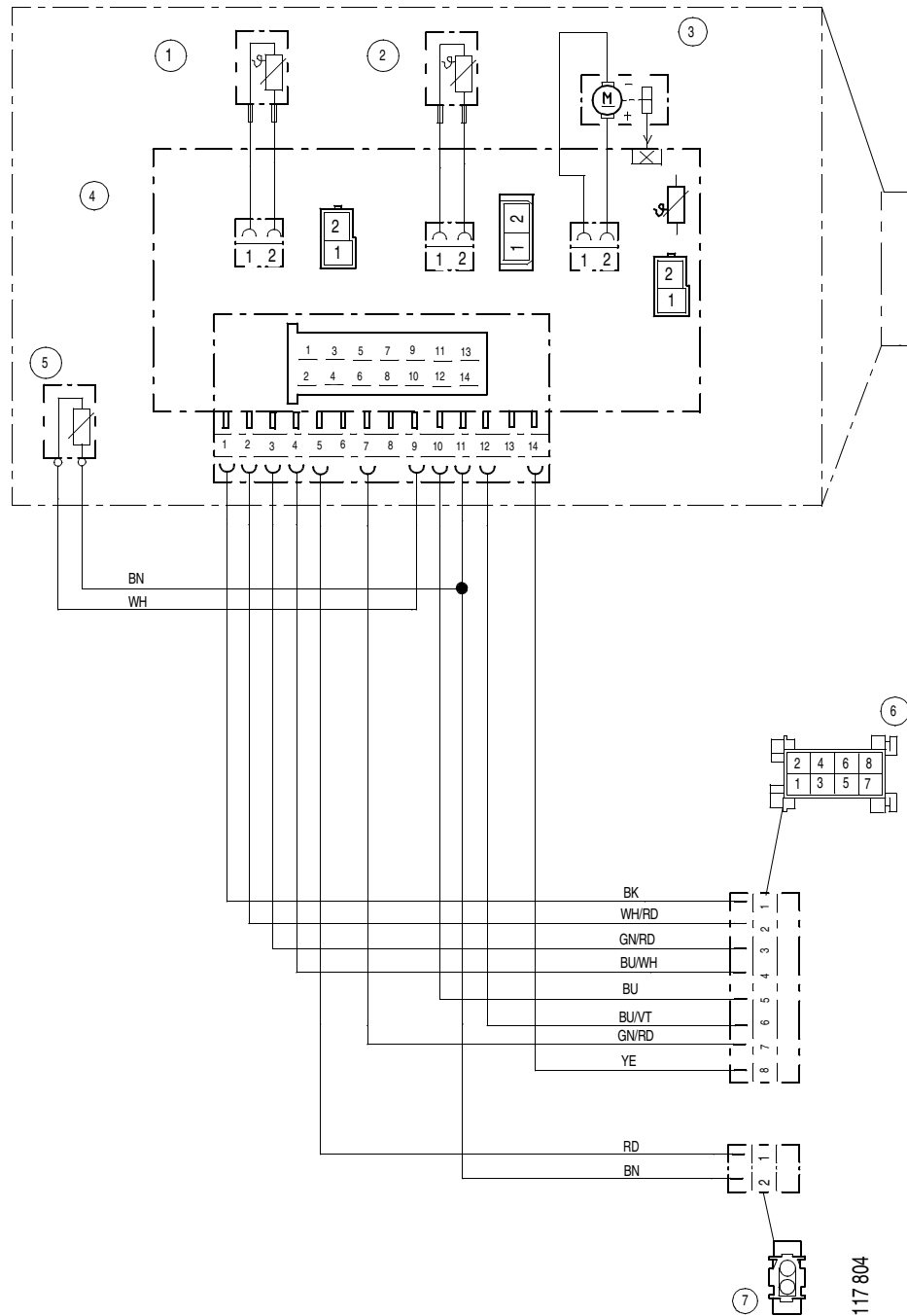

1 *Flame monitor*

2 *Overheat breaker*

3 *Burner motor*

4 *Control unit*

5 *Glow plug*

6 *Connector C479*

7 *Connector C255*